

DEPARTMENT OF THE ARMY
TECHNICAL MANUAL
DEPARTMENT OF THE AIR
FORCE TECHNICAL ORDER

TM 9-8240
T036A9-9-3-21

**OPERATION
ORGANIZATIONAL
MANNTENANCE
AND ORDNANCE
FIELD AND DEPOT
MAINTENANCE
12-TON, 4-WHEEL
WRECKER LOW-BED
SEMITRAILERS
M9, M270, AND M270A1**

This copy is a reprint which includes current
pages from Changes 1 thru 3.

DEPARTMENTS OF THE ARMY AND THE AIR FORCE
AUGUST 1957

Changes in force: C1, C2, C3

TM 9-8240
C 3

CHANGE }
No. 3 }

HEADQUARTERS
DEPARTMENT OF THE ARMY
WASHINGTON, D. C., 4 June 1985

**Operator's Organizational, Direct Support and General
Support Maintenance Manual**

FOR
SEMITRAILER, LOW-BED: WRECKER, 12-TON, 4-WHEEL
M269(NSN2330-00-395-1876)
M269A1(NSN2330-00-542-2980)
M270(NSN2330-00-395-1877)

TM 9-8240, 23 August 1957, is changed as follows:

Cover and title page is changed as shown above.

Page 3. Section I, GENERAL, paragraph 1 superseded in change 2 is superseded as follows:

1. Scope

This manual is for your use in operating and maintaining the 12-ton, 4-wheel, low bed wrecker semitrailer. It also provides descriptions of major units, their functions, and their relationship to other components of the equipment. M270A1, refer to TM 9-2330-371-14&P for Semitrailer, Low Bed: Wrecker, 12-Ton, 4-Wheel (NSN 2330-00-289-7515).

Page 4. Figure 1, title, "M270A1" is changed to read "M269A1."

Page 7. Figure 4, title, "M270A1" is changed to read "M269A1."

Page 10. Figure 7, title, "M270A1" is changed to read "M269A1."

Delete "M270A1 and" or "M270A1" as follows:

Page No.	Paragraph or Figure No.	Line No.
13	4 b	1
13	4 b (1)	2
14	5 c (1) 5 d (1)	1
15	5e(1), 5f (1), 5g (1)	1
16	5h (1)	1
17	6 f	3
20	10b (2) (a)	1
25	10i (1)	1
26	10j (1), 10k (1)	1
29	10l	2
31	11 b (1)	1
33	14a	7
34	15a	1
34	Figure 21	title
37	Figure 24	title
40	18a	5, 10, 17, 22
41	18a	5, 13
41	18b	5
41	18e	3, 6, 9
42	18g	4, 9
60	LO9-8240	title
74	46 b (6)	3
75	46c (7), 46 C (8)	1
75	46c (9)	3
75	46c (11)	2
75	46c (13)	1
75	46d (5)	3
75	46d (6), 46d (8)	1
76	49d (9)	1
76	46e (3), 46e (6)	3
76	46e (8)	1

Page No.	Paragraph or Figure No.	Line No.
76	46f (2)	3
76	46f (4)	1
82	53a (2)	2
84	53b (3)	13
85	53d, 53e	1
90	56b	1
95	58	1
99	62	2
102	66	1
105	68b (2)	1
107	69a (6)	1
110	72b (1)	1
111	72c (2)	1
112	74b (1), 74c (2)	1
113	77a	3
114	77C	1
121	85b (1), 85c (1)	1
123	85f (1)	1
124	85g (1)	1
133	90a	1
137	91a, 92a, 93a, 94	1
150	101a	1

Change "M270A1" to read M269A1 in figure title as follows:

Page No.	Figure No.
19	9
21	10
25	13
27	15
29	17
31	19

Page No.	Figure No.
33	20
46	29
90	41

Page 23. Paragraph 10c. Third sentence is deleted in its entirety.

Page 39. Figure 26, Delete.

Page 45. Paragraph 23, Line 1, "M270A1" is changed to read "M269A1."

Page 97. Paragraph 60d is rescinded.

Page 98. Paragraph 61c is rescinded.

Page 169. Paragraph 119. Line 2, change "M270A1" to read "M269A1."

Page 179. Line 12, "M270A1" is changed to read "M269A1. "

Page 179. Line 36, "M270A1" is changed to read "M269A1, "

Page 181. Line 20, "M270A1" is changed to read "M269A1. "

Page 181. Line 27, "M270A1" is changed to read "M269A1. "

By order of the Secretary of the Army:

JOHN A. WICKHAM, JR.
General, United States Army
Chief of Staff

Official:

DONALD J. DELANDRO
Brigadier General, United States Army
The Adjutant General

Distribution:

To be distributed in accordance with DA Form 12-39, Operator, organizational, Direct and General Support Maintenance requirements for Semitrailer, Low Bed, Wrecker 12-Ton, 4-Wheel, M269, M269A1, M270, M270A1.

CHANGE }
No. 2 }

HEADQUARTERS
DEPARTMENT OF THE ARMY
WASHINGTON, D.C. 31 August 1973

**Operator's Organizational, Direct Support and General
Support Maintenance Manual**

FOR
SEMITRAILER, LOW-BED: WRECKER, 12-TON, 4-WHEEL
M29 (2330-395-1876)
M269A1 (2330-542-2980)
M270 (2330-395-1877)
M270A1 (2330-289-7515)

This change current as of 15 April 1973

TM 9-8240, 23 August 1957, is changed as follows:

The title is changed to read as shown above.

Page 1, Chapter 4 title and Section I title. Change "Field and Depot" to "Direct Support and General Support".

Page 3, Section I. GENERAL, is superseded as follows:

1. Scope

This manual is for your use in operating and maintaining the 12-ton, 4-wheel, low bed wrecker semitrailer. It also provides descriptions of major units, their functions, and their relationship to other components of the equipment.

2. Forms and Records

Maintenance forms and records that you are required to use are explained in TM 38-750.

3. Reporting of Equipment Publication Improvements

The reporting of errors, omissions, and recommendations for improving this publication by the individual user is encouraged. Reports should be submitted on DA Form 2028 (Recommended Changes to Publications) and forwarded direct to Commander,

US Army Tank-Automotive Command, ATTN: AMSTA-MAPT,
Warren, MI 48090.

3.1. Destruction of Army Material to Prevent Enemy Use

Refer to TM 750-244-3.

3.2. Administrative Storage

Refer to TM 740-90-1 for Administrative Storage procedures.

Page 13, paragraph 4a(1), line 3. After “(figs. 3, 6, and 8)” add:
“and M269A1”.

Page 13, paragraph 4b. After M270A1 add in both places: “and
M269A1”.

Page 14; paragraph 5a, line 2. After “(figs. 3, 6, and 8)” add:
“and M269A1”.

Paragraph 5b. Delete second sentence “The frame of semitrailer
M270A1 . . . ”

Paragraphs 5c (1) and 5d (1). Add after “Semitrailer M270A1”:
“and M269A1”.

Page 15, paragraph 5e (1). Add after “Semitrailer M270A1”:
“and M269A1”.

Page 16, Paragraph 5g (2). Add after “Semitrailer M269”:
“and M269A1”.

Paragraph 5h (1). Add after “Semitrailer M270A1”:
“and M269A1”.

Page 17, paragraph 6f, line 3. Add after “M269”:
“and M269A1”.

Page 20, paragraph 10b(2)(a). Add after “Semitrailer M270A1
(fig. 10)”: “and M269A1”.

Page 25, paragraph 10i (1). Add after “Semitrailer M279A1”:
“and M269A1”.

Page 26, paragraph 10j(1). Add after “Semitrailer M270A1”:
“and M269A1”.

Paragraph 10k (1). Add after “Semitrailer M270A1 (fig. 15)”:
“and M269A1”.

Page 29, paragraph 10*l*, line 2. Add after “M270A1”: “and M269A1”.

Page 31, paragraph 11*b* (1). Add after “M270A1”: “and M269A1”.

Page 33, paragraph 14*a*, line 7. Add after “M270A1”: “and M269A1”.

Page 34, paragraph 15*a* and title of Figure 21. Add after “M270A1”: “and M269A1”.

Page 37. Add “and M269A1” to Figure 24’s title. Add the following note to center AMBER SERVICE and AMBER BLACKOUT clearance lights on both sides of the semitrailer; “(M270A1 only).”

Page 40, paragraph 18*a*. Add under Kingpin to landing gear: “M269A1 . . . 7 ft 3/4 in.”

Add under “Dimensions overall: Length”: “M269A1 . . . 34 ft 6 in.”

Add under “Dimensions overall: Length”: “M269A1 . . . 5 ft 10-9/16 in.”

Add under “Dimensions inside: Length”: “M269A1 . . . 34 ft 3-3/8 in.”

Page 41. Add after M269 for “Weights: Vehicle, 14,200 lb”: “and M269A1”.

Add after “M270A1” for Axle Manufacturer: “and M269A1”.

Add after “M270A1” for Brake Actuation: “and M269A1”.

Add after “M270A1” for Brake Make: “and M269A1”.

Page 42. Add the following

18.1 Components of End Item

These items are installed in the vehicle at time of manufacture or rebuild. They are securely fastened, permanently attached, or placed behind a cover. (*None authorized*).

18.2. Expendable - Consumable Maintenance Supplies and Materials

Supplies and materials required for maintenance support of the equipment covered herein are authorized to be requisitioned by SB 700-50. (Refer to table 0.1).

Table 0.1. Expendable Consumable Maintenance Supplies and Materials.

Federal Stock Number	Description	Unit of Meas	Qty Auth
	Grease, Automotive and Artillery, MIL-G-10924		
9150-190-0904	1 Lb Can	ea	V
5150-190-0905	5 Lb Can	ea	V
9150-190-0907	35 Lb Can	ea	V
	Hydraulic Fluid, Non-petroleum Base, Automotive (HB)		
9150-231-9071	1 Gal Can	ea	V
	Hydraulic Fluid, Non-petroleum Base, Automotive (Arctic Type) (HBA) MIL-H-13910		
9150-252-6375	1 Gal Can	ea	V
	Lubricating Oil, Internal Combustion Engine, Spec Mil-D-21046, OE/HDO-30		
Mil-D-21046, 9150-186-6681	1 Qt Can, Type I	ea	V
9150-188-9858	5 Gal Can	ea	V
9150-188-9859	55 Gal Drum (16 Ga)	ea	V
9150-189-6759	55 Gal Drum (18 Ga)	ea	V
	Lubricating Oil, Internal Combustion Engine, APG PD #1 Sub Zero (OES)		
9150-402-4478	1 Qt Can, Type I	ea	V
9150-402-2372	5 Gal Can	ea	V
9150-407-0972	55 Gal Drum (16 Ga)	ea	V
9150-491-7197	55 Gal Drum (18 Ga)	ea	V
	Preservative, Lubricating, Light Oil		
9150-231-9064	1 Qt Can	ea	V
9150-231-9065	1 Gal Can	ea	V

Page 45, paragraph 23, top line. Add after "M270A1": "M269A1".

Page 74-76, paragraph 46. Add "M269A1" after each appearance of "M270A1".

Page 82-85, paragraph 53. Add "M269A1" after each appearance of "M279A1".

Page 90, paragraph 56b. Add after "Semitrailer M270A1 (fig. 41)": "and M269A1".

Page 95, paragraph 58. Add after “(fig. 15)” in title: “and M269A1”.

Page 99, paragraph 62. Add after “Semitrailer M270A1” in title: “and M269A1”.

Page 102, paragraph 66. Add after “Semitrailer M270A1” in title: “and M269A1”.

Page 105, paragraph 68b (2), line 1. Add after “M270A1”: “or M269A1”.

Page 107, paragraph 69a (6), line 1. Add after “M270A1”: “or M269A1”.

Page 110, paragraph 72b(1). Add after “M270A1”: “and M269A1”.

Page 111, paragraph 72c(2). Add after “M270A1”: “and M269A1”.

Page 112, paragraphs 74b(1) and 74c(2). Add after “M270A1”: “and M269A1”.

Page 113, paragraph 77a, line 3. Add after “M270A1”: “and M269A1”.

Page 114, paragraph 77c, line 1. Add after “M270A1”: “and M269A1”.

Page 115. Change Chapter 4 title to: “DIRECT SUPPORT AND GENERAL SUPPORT MAINTENANCE INSTRUCTIONS”

Change Section I title to: “PARTS, SPECIAL TOOLS AND EQUIPMENT FOR DIRECT SUPPORT AND GENERAL SUPPORT MAINTENANCE”.

Paragraph 78. Change “. . . ordnance field maintenance units and depot shops . . .” to read: “. . . direct support and general support maintenance levels . . .”

Page 116. Change titles for Tables IV and Figure 50 to read: “Special tools for direct support and general support maintenance.”

Page 121, paragraphs 85b (1) and 85c (1). Add after “M270A1”: “and M269A1”.

Page 123, paragraph 85f(1). Add after "M270A1": "and M269A1".

Page 124, paragraph 85g(1). Add after "M270A1": "and M269A1".

Page 133, paragraph 90a. Add after "M270A1": "and M269A1".

Page 137, paragraphs 91a, 92a, 93a, 94. Add after "M270A1": "and M269A1".

Page 150, paragraph 101a. Add after "M270A1": "and M269A1".

APPENDIX III as added by Change 1 is superseded as follows:

BASIC ISSUE ITEMS LIST AND ITEMS TROOP INSTALLED OR AUTHORIZED LIST

Section I. INTRODUCTION

1. Scope

This appendix lists basic issue items and items troop installed or authorized required by the crew/operator for operation of the 12-ton, 4-wheel, low-bed wrecker semitrailers.

2. General

This appendix is divided into the following sections:

a. Basic Issue Items List—Section II. A list, in alphabetical sequence, of items which are furnished with and which must be turned in with the end item.

b. Items Troop Installed or Authorized List—Section III. A list, in alphabetical sequence, of items which, at the discretion of the unit commander, may accompany the end item but are not subject to be turned in with the end item.

3. Special Information

The following equipment publications are overpacked with the end item.

- a.* Equipment Maintenance Log – DA Form 2407 (one each).
- b.* Manual, Technical – TM 9-8240 (one each).
- c.* Order, Lubrication – LO 9-2330-220-12 (one each).

Section II. BASIC ISSUE ITEMS LIST

(None authorized)

Section III. ITEMS TROOP INSTALLED OR AUTHORIZED LIST

(None authorized)

By order of the Secretary of the Army:

CREIGHTON W. ABRAMS
General, United States Army
Chief of Staff

Official:

VERNE L. BOWERS
Major General, United States Army
The Adjutant General

DISTRIBUTION:

To be distributed in accordance with DA Form 12-39, operator maintenance requirements for Semi-trailer, Low Bed Wrecker, M269, M270, and 270A1.

TECHNICAL MANUAL

**Operator, Organizational and Field Maintenance Manual
SEMITRAILER, LOW-BED: WRECKER, 12-TON, 4-WHEEL,
M269, M270 AND M270A1**

TM 9-8240

CHANGES No. 1

HEADQUARTERS,
DEPARTMENT OF THE ARMY
WASHINGTON, D.C., 23 August 1963

TM 9-8240, 23 August 1957, is changed as follows:
The title is changed to read as shown above.

1. Scope

(Superseded)

a. This technical manual contains instructions for operation and organizational maintenance of the 12-ton, 4-wheel wrecker, low-bed, semitrailers M269, M270 and M270A1 for the using organization and instructions for field maintenance for ordnance personnel.

b. Appendix I contains a list of current references, including supply manuals, forms, technical manuals, and other available publications applicable to the wrecker low bed semitrailers, M269, M270, and M270A1.

c. Appendix II contains the maintenance allocation chart which lists the maintenance responsibilities for each echelon of maintenance.

d. Appendix III contains the basic issue items which are required for stockage by first-echelon maintenance and includes accessories, attachments, component assemblies, and subassemblies with quantities thereof, which constitute the major end item of equipment; and the first-echelon maintenance accessories, tools, supplies, and spare assemblies and parts accompanying the equipment, all of which constitute the major end item for issue to the users. These items are commonly known as "Basic Issue Items".

e. ORD 7-8 SNL G802 contains a list of repair parts and special tools for semi-trailers, M269, M270 and M270A1, with allocations for second through fourth echelon maintenance organizations.

f. TM 9-1827A contains disassembly, cleaning, inspection, repair, and assembly information on the compressed air reservoir, relay-emergency valves, brake hose, tubing, and fittings.

g. TM 9-1827C contains repair and rebuild instructions on brake wheel cylinders and the air hydraulic cylinders.

h. TM 9-1825E contains repair and rebuild instructions on intervehicular cables and harness.

i. In this manual, the terms "left" and "right" are used with respect to the driver's left and right as he sits in the driver seat of the towing vehicle.

j. Any errors or omissions will be forwarded on DA Form 2028 direct to the Commanding General, Army Tank-Automotive Center, ATTN: SMOTA-FMW, Detroit Arsenal, Center Line, Mich.

2. Maintenance Allocation

(Superseded)

a. *Operator's Maintenance Allocation.* Prescribed maintenance performed by the operator is contained in Chapter 2.

b. *Organizational Maintenance Allocation.* Prescribed maintenance performed by organizational personnel is shown in the organizational-maintenance (second echelon) column of the maintenance allocation chart (App. II).

c. *Field Maintenance Allocation.* Prescribed maintenance performed by field maintenance personnel is shown in the field maintenance (third and fourth echelon) columns of the maintenance allocation chart (App. II).

3. Forms, Records and Reports

(Superseded)

Refer to DA Pam 310-2 for a current and complete list of blank forms. For instructions on the use of maintenance forms, records and reports, refer to TM 38-750.

Page 43, paragraph 19b. Change "500 miles" to read: "25 miles"

20. Preliminary Services

(Superseded)

a. General Procedures.

- (1) If any exterior surfaces are coated with rust-preventive compound, remove the compound with dry cleaning solvent or mineral spirits paint thinner.
- (2) Read preparation record for storage or shipment tag and follow all precautions checked thereon.
- (3) Prior to performing the procedures in paragraph 21, perform the procedures in (b below).

b. Specific Procedures.

- (1) *Air reservoir.* Drain air reservoir and close drain cock.
- (2) *Air fillers.* Drain air filters and replace plugs.
- (3) *Air and electric connections.* Make sure these items are in good condition and secure.
- (4) *Electrical Wiring.* Examine all accessible wiring for chafing, cracking, and looseness of connections.
- (5) *Tires.* Gage all tires. Inflate to 50 pounds per square inch for normal travel. Remove nails, glass, or stones from treads. (If tires are hot, do not reduce air pressure.)
- (6) *Wheel cap nuts.* Be sure all inner and outer cap nuts are present and evenly tightened.

- (7) *Wheel bearings.* Inspect wheel bearings. If lubrication appears to be adequate, do not clean and repack.
- (8) *Tandem axle assembly.* Visually inspect trunnion axle, walking beams, and shackle boxes for loose nuts or damaged parts.
- (9) *Lights and reflectors.* Inspect all lights and reflector lens for breakage. Clean if necessary.
- (10) *Tools and equipment.* Check that all tools and equipment are present, in good condition, and properly stowed or mounted.
- (11) *Lubrication.* Lubricate according to lubrication order. Lubricate all grease fittings and oil can points, regardless of interval.

21. Break-in Procedures

(Superseded)

- a. It is the responsibility of the officer in charge to inspect the materiel to be sure it is in condition to perform its function.
- b. Perform a "break-in" of at least 25 miles at a maximum speed of 30 mph on all new or reconditioned materiel and a sufficient number of miles on used materiel to completely check their operation.

22. Correction of Deficiencies

(Superseded)

- a. Deficiencies will be corrected by the using organization or a higher maintenance echelon.
- b. Serious deficiencies, will be reported in accordance with instructions in paragraph 3.

32. Operation Under Unusual Conditions

(Superseded)

- a. It is imperative that the approved practices and precautions be followed. A detailed study of TM's 21-300 and 21-305 is essential for use of this materiel under unusual conditions.
- b. For description of operations in extreme cold, refer to TM 9-207.
- c. Under sandy or dusty conditions, inspect, clean and lubricate working parts frequently.

Page 55. Paragraph 33d(2). Delete reference to TM 31-200.

Page 56. Paragraph 36. Change "ORD 6 SNL J-7" and "ORD 6 SNL J-10" to read SM 9-4-5180-A17.

Page 57. Paragraph 38, delete reference to "fig. 32".

39. General Lubrication Instructions

* * * * *

c. *Points.*

- (1) Lubrication points shown in figures 33 and 34 are referenced to lubrication **chart (fig. 32)**. Wipe the lubricating *** lubricant is applied. **Refer to LO 9-2330-220-12 for official lubrication instructions.**

(2) Rescinded

* * * * *

Note. (Superseded) Lubricate wheel bearings at 2d "S" P.M. Service.

d. Reports and Records.

- (1) (Superseded) Report unsatisfactory lubricant performance using DA Form 2407.
- (2) Maintain a record of lubrication of the vehicle on DA Form 2403.

e. Lubrication Under Unusual Conditions.

* * * * *

- (2) Extreme cold weather. Refer to TM 9-207 for instruction on necessary special preliminary lubrication.

* * * * *

Page 60, figure 32. Change the title of figure 32 to read: Lubrication Chart.

Page 64.

Section III. PREVENTIVE-MAINTENANCE SERVICE

(Superseded)

41. General

The purpose of preventive-maintenance services is to detect first signs of electrical and mechanical failures of assemblies in the materiel, and to insure that appropriate corrective action is taken before expensive and time-consuming repairs or replacements are required. The system of preventive-maintenance services is based on frequent inspections and services accomplished by operators, company, battalion, or regimental maintenance personnel under active supervision by all commanders and leaders.

42. Responsibility

Operators and crew chiefs are personally responsible for assigned materiel pertaining to their commands. Unit and organization commanders are required to insure that materiel issued or assigned to their commands is properly maintained in a service condition and is properly cared for and used.

43. Intervals

The principal criterion for determining the frequency of preventive-maintenance services is mileage. Insofar as this is not practicable for the semi-trailer, the 6-month or semiannual interval will be used. Operation under adverse conditions such as extreme temperatures, dust, or mud, may require preventive-maintenance services to be performed more frequently. Reduce the interval between preventive-maintenance services when environmental conditions indicate the need. Do not extend the interval between preventive-maintenance services except when authorized to do so.

43.1. Outline

The system of preventive-maintenance services for semitrailers M172 and M172A1 is outlined in table 1.1. "A" services, as outlined, are designated first-echelon services. "S" or semiannual services are designated second-echelon services.

Table 1.1. (Added) Outline of Preventive-Maintenance Services

Service	Interval	Accomplished by
Daily.....	Each day operated.....	Operator or crew
Semiannual "S".....	Every 6 months.....	Organizational maintenance personnel assisted by operator or crew.

43.2. General Procedures for All Services and Inspections

a. The following general procedures apply to preventive-maintenance services and to all inspections and are just as important as the specific procedures.

b. Inspections to check that items are in *good condition, correctly assembled or stowed, secure, not excessively worn, not leaking, and adequately lubricated* apply to most items in the preventive-maintenance and inspection procedures. *Any or all of these checks that are pertinent to any item (including supporting, attaching, or connecting members) will be performed automatically, as general procedures, in addition to any specific procedures given.*

- (1) Inspection for *good condition* is usually visual inspection to determine if the unit is safe or serviceable. *Good condition* is explained further as meaning: not bent or twisted, not chafed or burned, not broken or cracked, not bare or frayed, not dented or collapsed, not torn or cut, and not deteriorated.
- (2) Inspection of a unit to see if it is *correctly assembled or stowed* is usually a visual inspection to see if the unit is in its normal position in the vehicle and if all its parts are present and in their correct relative positions.
- (3) Inspection of a unit to see if it is *secure* is usually a visual, hand-feel, pry-bar, wrench, or screwdriver inspection for looseness in the unit. This inspection will include any brackets, lock-washers, locknuts, locking wires, and cotter pins as well as any connecting tubes, hose, or wires.
- (4) *Excessively worn* is understood to mean worn beyond serviceable limits or likely to fail if not replaced before the next scheduled inspection. Excessive wear of mating parts or linkage connections is usually evidenced by too much play (lash or lost motion). **It includes illegibility as applied to markings, data and caution plates, and printed matter.**

- (5) Where instruction "tighten" appears in the procedures, it means tighten with a wrench, even if the item appears to be secure.
- (6) Such expressions as "adjust if necessary" or "replace if necessary" are not used in the specific procedures. *It is understood that whenever inspections reveal the need for adjustments, repairs, or replacements, the necessary action will be taken.*

43.3. Cleaning

a. General. Any special cleaning instructions required for specific mechanism or parts are contained in the pertinent section. General cleaning instructions are shown in (1) through (5) below.

- (1) Use dry cleaning solvent or mineral spirits paint thinner to clean or wash grease or oil from all parts of the semitrailer.
- (2) A solution of one part grease-cleaning compound to four parts of dry cleaning solvent or mineral spirits paint thinner may be used for dissolving grease and oil for gearboxes, chassis frame, hubs, and other parts. After cleaning use cold water to rinse off any solution which remains.
- (3) After the parts are cleaned, rinse and dry them thoroughly. Apply a light grade of oil to all polished metal surfaces to prevent rusting.
- (4) Name, data, and service plates made of steel rust very rapidly. When they are found to be in a rusty condition, they should be thoroughly cleaned and heavily coated with an application of lacquer. Refer to TM 9-2851.
- (5) Before installing new parts, remove any preservative materials, such as rust-preventive compound and protective grease; prepare parts as required (oil seals, etc.); and for those parts requiring lubrication, apply the lubricant prescribed in LO 9-2330-220-12.

b. General Precautions in Cleaning.

- (1) Dry cleaning solvent or mineral spirits paint thinner is flammable and should not be used near an open flame. Fire extinguishers should be provided when these materials are used. In addition, they evaporate quickly and have a drying effect on the skin. If used without gloves, they may cause cracks in the skin, and in the case of some individuals, a mild irritation or inflammation. Use only in well ventilated places.
- (2) Avoid getting products such as dry cleaning solvent or mineral spirits paint thinner, engine fuels, or lubricants on rubber parts as they will deteriorate the rubber.
- (3) The use of diesel fuel oil, gasoline, or benzene (benzol) for cleaning is prohibited.

43.4. Daily Preventive-Maintenance Services

The daily preventive-maintenance service is a systematic inspection of the vehicle each day it is operated so that defects may be discovered and corrected before they result in serious damage or failure. This service is performed by the operator and is divided into three parts as indicated in *a* through *c* below. Any defect or unsatisfactory operating characteristic noted during any part of this service that is beyond the scope of the operator, will be reported to the designated individual in authority at the earliest opportunity.

a. Before-Operation Service. This is a brief service to ascertain that the materiel is ready for operation; it is mainly a check to determine if conditions affecting the materiel's readiness have changed since the last after-operation service.

b. During-Operation Service. This service consists of detecting unsatisfactory performance. The driver of the towing vehicle should be alert for any unusual noises, steering irregularities, or any other indications of malfunction of any part of the semitrailer. Each time the airbrakes are applied or the semitrailer is turned, the operator should instinctively consider it a test and note any unusual or unsatisfactory performance.

c. After Operation Service. This service consists of investigating any deficiencies noted during operation and repeating part of the before-operation service. It is the basic service for tactical materiel and consists of correcting, insofar as possible, any operating deficiencies.

d. Specific Procedures for First Echelon. Table II gives the specific procedures to be performed on the semitrailer by the operator in daily service. A number in a column means that the procedure opposite it should be performed during that part of the daily service in which it appears.

Table II. (Superseded) Preventive Maintenance Checks and Services
1st Echelon Daily Schedule

Interval and sequence No.			Items to be inspected	Procedure	Paragraph reference
Before operation	During operation	After operation			
1	-----	-----	TIRES	<p style="text-align: center;">USUAL CONDITIONS</p> <p><i>Caution; Place all tags describing condition of vehicle in a conspicuous location so that they will not be overlooked.</i></p> <p>Gage tires for correct pressure.</p> <p>Remove penetrating objects such as nails or glass. Remove stones from between duals. Note any apparent loss of air, unusual wear, or missing valve caps.</p>	<p>12</p> <p>43</p>

Table II. (Superseded) Preventive Maintenance Checks and Services—Continued

1st Echelon			Daily Schedule		
Interval and sequence No.			Items to be inspected	Procedure	Paragraph reference
Before operation	During operation	After operation			
2			VEHICLE EQUIPMENT	Visually inspect wheel covers (if used) and vehicle publications.	19
3			LIGHTS	Operate lights from the towing vehicle (if tactical situation permits) and observe functioning. Visually inspect lamp body, reflectors, and towing connections.	71-75
4				Visually inspect compartment covers, and landing gear crank for secure fastening.	65
	10		VEHICLE	Be alert for any unusual noises, abnormal condition, or improper operation of towing connections, brakes, or other mechanism.	
	11		VEHICLE	Investigate and correct or report any faults noted during operation.	
5			AXLE	Look at axles to see if they have been damaged.	Fig. 57
6			WHEELS	Inspect wheel cap nuts and hub cover screws to see that they are present and secure.	53
7			BRAKE HOSES AND CABLES	Make certain that emergency and service airbrake hoses and the intervehicular cable are securely connected and in good condition.	23-31
	12		BRAKES	Any time the brakes are used, consider it a test and note any unusual or unsatisfactory performance.	56-67
8			BRAKE AIR RESERVOIR	Drain condensation	56-67
9			VEHICLE	Wash if possible, otherwise wipe off or sweep exterior.	
	13		LUBRICATION	Lubricate items specified on LO 9-2330-220-12.	

44. General Procedures for Second Echelon

a. *Application.* All of the general procedures given in Table III will be followed. Organizational mechanics must be so thoroughly trained

in these procedures that they apply them automatically at all times in the performance of these duties.

b. First Echelon Participation. The drivers or operators should accompany their vehicles and assist the mechanics while periodic organizational preventive maintenance services are performed. Ordinarily, the driver should present the vehicle for a scheduled preventive-maintenance service in a reasonable clean condition.

c. Special Services. These are indicated by number in the columns which show the interval at which the services are to be performed, and show that the parts or assemblies are to receive certain mandatory services. Second-echelon services are defined by and restricted to the following general procedures unless approval has been given by the supporting ordnance organization. The special services are as shown in (1) through (5) below.

- (1) *Adjust.* Make all necessary adjustments in accordance with the pertinent section of this manual, technical bulletins, or other current directives.
- (2) *Clean.* Clean the unit as outlined in paragraph 43.3 to remove old lubricant, dirt, and other foreign material.
- (3) *Special lubrication.* This applies either to lubrication-operations that do not appear on the vehicle lubrication order or to items that do appear but which should be performed in connection with the maintenance operations if parts have to be disassembled for inspection or service.
- (4) *Service.* This usually consists of performing special operations, such as draining and refilling units with oil, and changing or cleaning the air filter or element.
- (5) *Tighten.* All tightening operations should be performed with sufficient wrench torque (force on the wrench handle) to tighten the unit according to good mechanical practice. Use a torque-indicating wrench where specified. Do not overtighten, as this may strip threads or cause distortion. Tightening will always be understood to include the correct installation of lockwashers, locknuts, locking wire, or cotter pins provided to secure the tightened nut.

d. Special Condition. When conditions make it difficult to perform the complete preventive-maintenance procedures at one time, they can sometimes be handled in sections, planning to complete all operations within the week, if possible. All available time at halts and in bivouac areas must be utilized, if necessary, to assure that maintenance operations are completed. When limited by the tactical situation, items, with special services in the columns of Table III, should be given first consideration.

e. Procedures for Second Echelon. Table III lists the services to be performed by the organizational mechanic or maintenance crew at 6-months intervals. Each item should be serviced in the order given.

Table III. (Superseded) Preventive Maintenance Checks and Services

2nd Echelon

Semiannual Schedule

Se- quence No.	Item to be inspected	Procedure	Paragraph reference
		PERFORM PRIOR TO ROAD TEST	
		<i>Note.</i> When the tactical situation does not permit a full road test, perform only those items that require little or no movement of the vehicle.	
1	TIRES	Inspect tires for unusual wear, penetrating objects and proper matching of tread.	12
2	LIGHTS AND REFLECTORS	Examine lights and reflectors.....	71-75
3	BRAKE AIR PRESSURE	Inspect for leaks in the airbrake system by stopping the engine of the towing vehicle when the air pressure is at a maximum and noticing if there is any appreciable drop on the air pressure gage within 1 minute.	56-67
		PERFORM DURING ROAD TEST	
4	BRAKES	Make several stops noting side pull, noise chatter or any other unusual conditions.	71-75
5	UNUSUAL NOISES	At all times during the road test, be alert for unusual or excessive noises that may indicate looseness, defects, or deficient lubrication.	
		PERFORM AFTER ROAD TEST	
6	BRAKE DRUMS AND HUBS	Immediately after the road test, feel these units cautiously. An overheated wheel hub and brake drum indicate an improperly adjusted, defective or dry wheel bearing, or a dragging brake. An abnormally cool condition indicates an inoperative brake.	71-75
7	LEAKS	Make general observation under hubs and under landing gear for grease or oil leaks.	54-55
8	LUBRICATION	Lubricate vehicle in accordance with lubrication order. Coordinate with inspection and disassembly operations to avoid duplication.	38-40
9	BRAKES	Inspect brake hose and brake air chambers and test linkage for freedom of action. Drain water from air reservoir.	56-67
10	WHEEL BEARINGS	If the wheel bearings are due for repacking, remove wheels and hubs and make observations of the brake internal components, clean the spider.	38-40

Table III. (Superseded) Preventive Maintenance Checks and Services—Continued
2nd Echelon **Semiannual Schedule**

Se- quence No.	Item to be inspected	Procedure	Paragraph reference
11	VEHICLE	Inspect stake pockets and lashing rings. Test operation of doors and latches. Examine condition of paint and leg- ibility of markings on identification and data plates.	17
12	KINGPIN AND KINGPIN PLATE	Inspect kingpin and kingpin plate. Look particularly for security of mountings and adequate lubrication.	Fig. 33
13	VEHICLE	Perform final road test. Pay particular attention to items that have been re- paired.	

Page 73.

Section IV. Troubleshooting

(Superseded)

45. Scope

This section contains troubleshooting information and tests for locating and correcting some of the troubles which may develop in the semi-trailer. Troubleshooting is a systematic isolation of defective components by means of an analysis of vehicle trouble symptoms testing to determine the defective component and applying the remedies. Standard automotive theories and principles of operation apply in troubleshooting the semitrailer. Question vehicle driver or operator to obtain maximum number of observed symptoms. The greater the number of symptoms of troubles that can be evaluated, the easier will be the isolation of the defect. Each symptom of trouble or malfunction listed in Table V is followed by a list of probable causes of the trouble, and corrective action necessary to remedy the malfunction.

46. General

This technical manual does not cover all possible troubles and deficiencies that may occur under the many conditions of operation. If a specific trouble is not covered herein, proceed to isolate the system in which the trouble occurs and then locate the defective component. Do not neglect use of any test instruments.

Table III.1. (Added) Troubleshooting

Malfunction	Probable causes	Corrective action
	FRAME	
1. Semitrailer leans or tilts.	a. Sprung frame	a. Heat and use jacks to straighten frame assembly.

Table III.1. (Added) Troubleshooting—Continued

Malfunction	Probable causes	Corrective action
2. Noise from frame...	<p>b. Weak or broken frame.</p> <p>c. Crossmembers broken or damaged.</p> <p>a. Loose crossmembers...</p> <p>b. Loose or broken load bed boards.</p> <p>c. Loose components beneath semitrailer.</p>	<p>b. Reinforce and weld frame assembly.</p> <p>c. Weld or reinforce crossmembers.</p> <p>a. Inspect crossmembers for broken welds. Weld or install patch plate as necessary.</p> <p>b. Secure load bed boards with new cap screws or replace boards.</p> <p>c. Inspect air filters, air reservoir tank hangers relay emergency valve, tail and marker lights, hose couplings, air lines, and landing gear mechanism for loose mounting. Tighten necessary screws and nuts to secure each item to frame.</p>
LANDING GEAR		
3. Landing gear can not be lowered or raised to correct position.	<p>a. Damaged upper or lower leg tube.</p> <p>b. Damaged or loose bevel gear, sliding gear, or rigid gear.</p>	<p>a. Replace damaged leg or assembly (par's. 68, 69 & 99).</p> <p>b. Disassemble gearbox and repair or replace damaged gear.</p>
4. Landing gear does not move when crank is turned.	<p>a. Sheared Woodruff key, pins, or cotter pins.</p> <p>b. Damaged bevel gear, sliding gear, rigid gear, or screw.</p>	<p>a. Disassemble gearbox and replace Woodruff key, pins, or cotter pins (par's. 68, 69 & 99).</p> <p>b. Disassemble landing gear assembly, and inspect bevel gear, sliding gear, rigid gear, and screw for broken teeth or damaged threads. Replace defective parts (par's. 68, 69 & 99).</p>
5. Handcrank will not turn.	<p>c. Loose or missing gib...</p> <p>a. Bent handcrank shaft...</p> <p>b. Damaged crankshaft or bevel gear shafts.</p> <p>c. Damaged elevating screw or key.</p>	<p>c. Install gib and gib plug.</p> <p>a. Replace shaft (par's. 68 & 69).</p> <p>b. Disassemble gear box and replace damaged shafts (par's. 68, 69 & 99).</p> <p>c. Disassemble landing gear and replace screw or feather key (par's. 68, 69 & 99).</p>
6. Handcrank does not turn freely.	<p>a. Lack of lubrication...</p> <p>b. Bent bevel gear shaft or crankshaft.</p>	<p>a. Lubricate handcrank (par. 39).</p> <p>b. Disassemble gear box and replace bent shaft (par's. 68, 69 & 99).</p>

Table III.1. (Added) Troubleshooting—Continued

Malfunction	Probable causes	Corrective action
TANDEM AXLE ASSEMBLY		
7. Hard pulling-----	<ul style="list-style-type: none"> a. Dragging brakes----- b. Improper wheel bearing adjustment. c. Bent axle----- d. Dragging axle, lost U-bolt. 	<ul style="list-style-type: none"> a. Adjust brakes (par. 56). b. Adjust wheel bearing (par. 53). c. Repair or replace axle (par. 85). d. Aline axles and secure.
8. Excessively worn scuffed, or cupped tires.	<ul style="list-style-type: none"> a. Improper tire pressure-- b. Loose wheels----- c. Loose wheel bearings--- d. Bent rim or wheel----- e. Bent axle----- 	<ul style="list-style-type: none"> a. Inflate tires to proper pressure (par. 12). b. Tighten cap nuts. c. Adjust wheel bearings (par. 53). d. Replace wheel (par. 52). e. Repair or replace bent axle (par. 85).
WHEELS, HUBS, BEARINGS AND TIRES		
9. Noise-----	<ul style="list-style-type: none"> a. Brakeshoes drag on drums. b. Brakedrums out-of-bound. c. Broken brakeshoe return spring. d. Loose wheel stud nuts-- e. Damaged wheel bearings. f. Wheel bearings not properly adjusted. g. Obstruction between dual wheels or in tire tread. h. Bent or damaged wheels or hubs. 	<ul style="list-style-type: none"> a. Adjust brakes (par. 56). b. Repair or replace brakedrums (par. 53). c. Replace broken return spring (par. 46). d. Tighten loose wheel stud nuts. e. Replace damaged wheel bearings. (par. 53). f. Adjust wheel bearings (par. 53). g. Remove obstruction. h. Replace damaged wheels or hubs (par's. 52 & 53).
10. Wobbly wheels---	<ul style="list-style-type: none"> a. Loose cap nuts----- b. Improperly adjusted or damaged wheel bearings. c. Bent axle spindle----- d. Bent or damaged wheels. 	<ul style="list-style-type: none"> a. Tighten or replace cap nuts (par. 52). b. Adjust or replace wheel bearings. (par. 53). c. Replace axle (par. 85). d. Replace damaged wheels.
11. Overheated hubs--	<ul style="list-style-type: none"> a. Lack of wheel bearing lubricant. b. Wheel bearings improperly adjusted. 	<ul style="list-style-type: none"> a. Lubricate wheel bearings (par.'s 53 & 39). b. Adjust wheel bearings (par. 53).

Table III.1. (Added) Troubleshooting—Continued

Malfunction	Probable causes	Corrective action
12. Overheated brakedrum.	<ul style="list-style-type: none"> c. Damaged bearing or cup. d. Damaged hub e. Bent axle spindle f. Overloading or unbalanced distribution of load. 	<ul style="list-style-type: none"> c. Replace damaged bearing or cup (par. 53). d. Replace damaged hub (par. 53). e. Check for bend and replace tubular axle (par. 85). f. Check load weights hauled and keep within rated gross capacity. Arrange load evenly to distribute weight.
13. Brakes grabbing . . .	<ul style="list-style-type: none"> a. Dragging brakeshoe assembly. b. Broken brake lining . . . c. Broken or weak brakeshoe return spring. d. Bent axle spindle 	<ul style="list-style-type: none"> a. Adjust brakes (par. 56). b. Replace brakeshoe assembly (par. 57). c. Replace defective return spring (par. 46). d. Replace axle (par. 85).
14. Undue wear of any or all tires.	<ul style="list-style-type: none"> a. Loose or worn wheel bearing. b. Cracked or deformed brake drum. c. Loose or cracked brake lining. d. Improper brake adjustment. e. Grease on brake lining. 	<ul style="list-style-type: none"> a. Adjust bearing (par. 53). If worn replace (par. 53). b. Replace brake drum (par. 53). c. Replace brakeshoe assembly (par. 57). d. Adjust brakes (par. 56). e. Replace brakeshoes (par. 53). Clean brakedrum. Examine grease seal, replace if necessary. (par. 53).
15. Undue wear of any or all tires.	<ul style="list-style-type: none"> a. Incorrect tire inflation. b. Overloading c. Brake action too severe. 	<ul style="list-style-type: none"> a. Inflate tires to proper pressure. Tighten valve cap fingertight. b. Check load weights hauled and keep within rated gross capability. c. Check and adjust brakes (par. 56).
16. Air leakage from tires.	<ul style="list-style-type: none"> a. Tires not properly matched. 	<ul style="list-style-type: none"> a. With tires properly inflated check overall circumference of tires. The difference in overall circumference must not exceed the $\frac{3}{4}$ inch limits. Remove wheel and tire assembly (par. 52) and match tires.
16. Air leakage from tires.	<ul style="list-style-type: none"> a. Valve core loose or damaged. b. Punctured tube 	<ul style="list-style-type: none"> a. Tighten or replace. b. Repair tube.

Table III.1. (Added) Troubleshooting—Continued

Malfunction	Probable causes	Corrective action
AIRBRAKE SYSTEM		
17. No brakes-----	<p>a. Source of air supply shut off at towing vehicle.</p> <p>b. Airbrake hose between semitrailer and towing vehicle not properly coupled.</p> <p>c. Air reservoir drain cock open.</p> <p>d. Air leakage in brake system.</p> <p>e. Low air pressure-----</p> <p>f. Defective relay-emergency valve (fig. 21).</p> <p>g. Brake air chamber inoperative.</p> <p>h. Brakes need adjustment.</p> <p>i. Clogged air filter-----</p>	<p>a. Open air line valves at rear of towing vehicle.</p> <p>b. Examine airbrake hose to make sure that hoses marked SERVICE and EMERGENCY are properly connected to the semitrailer and towing vehicle (par. 31).</p> <p>c. Make certain air reservoir drain cocks on both the semitrailer and towing vehicle are closed.</p> <p>d. Examine all airhose, lines and connecting units, in the brake system for air leaks. Replace units that are found defective (par. 46C).</p> <p>e. Check air pressure gage on towing vehicle. Pressure must not be below 80 psi (par. 46C).</p> <p>f. Replace defective valve (par. 60).</p> <p>g. Check for punctured diaphragm. Replace air chamber or diaphragm in air chamber (par. 62).</p> <p>h. Adjust brakes (par. 56).</p> <p>i. Remove and clean air filter element (par. 10).</p>
18. Insufficient brakes.	<p>a. Improper brake adjustment or worn brake linings.</p> <p>b. Improper slack adjuster adjustment.</p> <p>c. Clogged air filter-----</p> <p>d. Air leakage in brake system.</p> <p>e. Low air pressure-----</p> <p>f. Restriction in airhose or lines.</p>	<p>a. Adjust brakes (par. 56) or replace brakeshoes assemblies as necessary (par. 57).</p> <p>b. Adjust slack adjuster (par's. 64 & 98).</p> <p>c. Remove and clean air filter element (par's. 10 & 95).</p> <p>d. Examine for air leaks in brake system. Replace units that are found defective (par. 46C).</p> <p>e. Check air pressure gage vehicle cab. Pressure must not be below 80 psi (par. 46C).</p> <p>f. Look for dented or kinked air lines. Examine airhose to make sure it is not pinched between other units on the semitrailer. Repair or replace</p>

Table III.1. (Added) Troubleshooting—Continued

Malfunction	Probable causes	Corrective action
		damaged lines as outlined in TM 9-1827A.
19. Slow brake	<p>g. Lack of lubrication</p> <p>a. Maximum brake chamber pushrod travel.</p> <p>b. Weak brakeshoe return.</p>	<p>g. Lubricate anchor pins, cams, slack adjuster, and brake chamber pushrod pins (par. 39).</p> <p>a. Adjust slack adjuster (fig. 64 & 98) and adjust brakes as necessary (par. 56).</p> <p>b. Check brakeshoe return spring replace if found to be weak (par. 46).</p>
20. Grabbing brakes	<p>a. Lubricant on brake lining.</p> <p>b. Loose brake lining</p> <p>c. Loose or worn wheel bearings.</p> <p>d. Distorted brake linings.</p>	<p>a. Inspect for lubricant on brake lining. Replace brakeshoe assembly (par. 53) if lubricant on lining is evident.</p> <p>b. Inspect brake lining for sheared or worn rivets or bolts. Replace defective brakeshoe assembly (par. 57).</p> <p>c. Adjust wheel bearings (par. 53). If adjustment of wheel bearings does not correct the condition of loose wheels, replace bearings (par. 53).</p> <p>d. Replace brakeshoe assembly (par. 57).</p>
21. Noisy brakes	<p>a. Linings or rivets loose.</p> <p>b. Road grit, rust, or metal particle in brake drum or lining.</p> <p>c. Brakedrum out-of-round or scored.</p>	<p>a. Replace brakeshoe assembly (par. 57).</p> <p>b. Clean brakedrum and lining. Replace brakeshoe assembly (par. 57) if grit or metal particles are embedded in the lining.</p> <p>c. Repair or replace brakedrum (par. 53).</p>
22. Service airbrake pressure drops.	<p>a. Excessive leakage in relay emergency valve (fig. 25 and 26) and exhaust port.</p> <p>b. Air leakage at line connectors.</p> <p>c. Leakage at service or emergency line couplings.</p> <p>d. Air leakage at service or emergency airhose coupling (fig. 10 and 11) when towing vehicle service airhose is disconnected.</p>	<p>a. Replace relay emergency valve (par. 60).</p> <p>b. Tighten connectors until air leakage disappears. If air leakage persists, replace defective connectors on air lines.</p> <p>c. Couplings are improperly connected or packing gasket is damaged. (par's. 46 and 104).</p> <p>d. Replace relay-emergency valve (par. 60).</p>

Table III.1. (Added) Troubleshooting—Continued

Malfunction	Probable causes	Corrective action
23. All lights fail to light.	<ul style="list-style-type: none"> a. Intervehicular cable not properly plugged into receptacles on semitrailer and towing vehicle. b. Light switch on towing vehicle malfunctioning. c. No current from towing vehicle. d. Short circuit in wiring. e. Dirty or corroded contacts in receptacle or on plug of intervehicular cable. f. Dirty or corroded contacts in connectors of semitrailer wiring. 	<ul style="list-style-type: none"> a. Pull plugs out and reinsert them. Be sure plugs seat properly. b. Check light switch. c. Check circuit breaker and wiring on towing vehicle. d. Check wiring for bare spots in insulation. e. Clean receptacle and plug. f. Clean corroded contacts in connectors.
24. Lights burn dim or flicker.	<ul style="list-style-type: none"> a. Loose, dirty, or corroded terminals. b. Poor or loose ground... c. Defective lamps..... d. Dirty or corroded lamp socket or contact in receptacle or on plug of intervehicular cable. 	<ul style="list-style-type: none"> a. Clean and tighten terminals. b. Clean and tighten terminals on short (ground) cable in back of receptacle assembly on semitrailer. c. Replace defective lamp (par's 72 & 75). d. Clean or replace lamp socket, receptacle or plug.
25. Individual lamps do not light.	<ul style="list-style-type: none"> a. Burned out lamp..... b. Broken or loose connection. c. Damaged light assembly. d. Dirty or corroded lamp sockets. e. Dirty or corroded contact in receptacle or on plug of intervehicular cable. 	<ul style="list-style-type: none"> a. Replace lamp (par's. 72 & 75). b. Check cables for breaks and poor connections, tighten, repair or replace. Clean connections. c. Repair or replace light assembly (par's. 72 & 75). d. Remove lamp and clean contacts. e. Clean receptacle and plug.

APPENDIX I (Superseded)

REFERENCES

1. Publication Indexes

The following indexes should be consulted frequently for latest changes or revisions and for new publications relating to materiel covered in this technical manual.

Index of Army Pictures, Television Recordings
and Film Strips.....DA PAM 108-1

Military Publications:

Index of Administrative publications.....DA PAM 310-1

Index of Blank Forms.....DA PAM 310-2

Index of Doctrinal, Training and Organizational
Publications.....DA PAM 310-3

Index of Technical Manuals, Technical Regula-
tions, Technical Bulletins, Supply Bulletins,
Lubrication Orders, and Modification Work
Orders.....DA PAM 310-4

Index of Graphic Training Aids and Devices.....DA PAM 310-5

Index of Supply Manuals—Ordnance Corps.....DA PAM 310-29

2. Forms

Refer to TM 38-750 The Army Equipment Record System and Procedures, for instructions on the use of maintenance forms pertaining to this materiel.

APPENDIX II (Added)

MAINTENANCE ALLOCATION CHART

Purpose

To allocate specific maintenance operations to the proper echelon.

Basis

Allocation of maintenance operations is made on the basis of time, tools and skills normally available to the various echelons in a combat situation and influenced by maintenance policy and sound maintenance practices as outlined in TM 38-750 and FM 9-3 and FM 9-4.

Implementation

Constructive comments and criticism pertaining to any operation or allocation of responsibility contained in this chart are encouraged and should be properly forwarded to the Chief, Maintenance Division, this Headquarters, for consideration at the time of revision or change.

Explanations and Definitions

The Maintenance Allocation Chart designates overall responsibility for the maintenance function on an end item or assembly. Repair and/or rebuild of major assemblies is designated by authority of the Army Commander representative, except for the specific subfunctions listed in the Maintenance Allocation Chart. Deviation from maintenance operations allocated in the Maintenance Allocation Chart are authorized only upon approval of the Army Commander representative.

<i>Service</i>	To clean, to preserve, and to replenish fuel and lubricants.
<i>Adjust</i>	To regulate periodically to prevent malfunction.
<i>Remove and Install</i>	To remove and install the same item for service, or when required for the performance of other maintenance operations.
<i>Replace</i>	To substitute serviceable assemblies, subassemblies and parts for unserviceable components.
<i>Repair</i>	To restore to a serviceable condition by replacing unserviceable parts or by any other action required; utilizing tools, equipment and skills

available, to include welding, grinding, riveting, straightening, adjusting, etc.

*Second Echelon
"C" and "D"*

"C" and "D" column refers to those maintenance operations authorized to be performed with the company or battery. "D" column refers to those maintenance operations authorized to be performed at separate company and separate battery, battalion and/or regimental level. "C" and "D" columns are intended as guide for unit commander and motor pool officers in the performance of Organizational Maintenance. Deviation from this guide with Second Echelon is authorized where considered appropriate by the commander.

Maintenance Allocation Chart

Group No.	Component and related operations	Echelons						Tools req'd	Remarks
		1st	C	D	3d	4th	5th		
			2d						
1	2	3	4	5	6	7	8	9	10
GROUP 06 ELECTRICAL SYSTEM									
0609.1	Lamps and lamp units replace.....		X						
	Lights replace.....		X						
	repair.....				X				
0613.1	Harness, wiring chassis replace.....			X					
	repair.....			X					
0617	Coupling, trailer, electric replace.....		X						
	repair.....				X				
GROUP 11 AXLE									
1100	Axle replace.....			%%	X				
1108	Axle, trunnion replace.....			%%	X				
GROUP 12 BRAKES									
1202	Shoe, brake, service replace.....			X					
	reline.....				X				

Maintenance Allocation Chart—Continued

Group No.	Component and related operations	Echelons						Tools req'd	Remarks
		1st	C	D	3d	4th	5th		
			2d						
1	2	3	4	5	6	7	8	9	10
1204.1	Cylinder, master replace..... repair.....		X						
1204.3	Cylinder, wheel replace..... repair.....		X						
1204.5	Lines, fittings, & hose replace..... repair.....		X						
1208.1	Cock, shut-off, trailer brake replace..... repair.....		X						
	Couplings, air replace.....		X						
	Lines and fittings replace..... repair.....								
	Ring, packing coupling replace.....		X						
	Spring, air brake hose coupling replace.....		X						
1208.3	Chamber, air brake replace..... repair.....								
	Valves, air system replace..... repair.....								
	Element, air filter replace..... service.....		X						
	Filter, air replace..... repair.....		X						
1209.3	Reservoir, air replace.....		X						
	Cock, drain replace.....		X						
	GROUP 13 WHEELS, HUBS AND DRUMS								
1311	Bearings, hub replace.....								

Maintenance Allocation Chart—Continued

Group No.	Component and related operations	Echelons						Tools req'd	Remarks
		1st	C	D	3d	4th	5th		
			2d						
1	2	3	4	5	6	7	8	9	10
1311	Drum, service brake								
	replace.....			X					
	repair.....				X				
	Hub, wheel								
	replace.....			X					
	Seal								
	replace.....			X					
1313	Slingers, oil, brake drum								
	replace.....			X					
	Studs, hub and wheel								
	replace.....			X					
	Wheels								
	replace.....		X						
	rebuild.....						X		
	Tires								
	replace.....		X						
	repair.....						X		
1313	Tubes								
	replace.....		X						
1313	repair.....		X						
	GROUP 15 FRAME AND BRACKETS								
1504	Carrier, spare wheel								
	repair.....			X					
1506	Plate, fifth wheel								
	repair.....				X				
1507	Crank, landing gear								
	replace.....		X						
	repair.....			X					
1507	Foot, landing gear								
	replace.....		X						
1507	Leg								
	replace.....			X					
	repair.....				X				
1507	Shaft, intermediate bevel gear								
	replace.....			X					
GROUP 16 SPRINGS									
1601.3	Seat, spring								
	repair.....		X						

Maintenance Allocation Chart—Continued

Group No.	Component and related operations	Echelons						Tools req'd	Remarks
		1st	C	D	3d	4th	5th		
			2d						
1	2	3	4	5	6	7	8	9	10
1605	Spring replace.....		X						
	repair.....			X					
	Rods, torque replace.....		X						
	repair.....				X				
	<i>GROUP 18 HULL</i>								
1810	Deck repair.....				X				
	<i>GROUP 22 MISCELLANEOUS ACCESSORIES</i>								
2202	Reflector replace.....		X						
2210	Plates, vehicle data replace.....		X						

APPENDIX III (Added)

BASIC ISSUE ITEMS LIST

Section I. INTRODUCTION

1. General

This appendix is a list of On-Equipment Materiel required for the first echelon operation and maintenance of the major end item. These items consist of accessories, attachments, component assemblies, tools, supplies and repair parts accompanying the equipment.

2. Explanation of Columns

a. Illustrations. This column indicates the figure number of the illustration that depicts the item. When more than one item appears on an illustration, the item number is also indicated.

b. Source, Maintenance, and Recoverability Code. This column lists the numerical code of the technical service, other than Ordnance, maintaining control responsibility of the item and the expendability and recoverability aspects of the item.

c. Federal Stock Number. This column lists the Federal stock number which has been assigned by the Cataloging Division, Armed Forces Supply Support Center.

d. Description. This column lists the Federal item name and any additional description required for supply operations. The abbreviation "w/e" (with equipment) when used as a portion of the nomenclature indicates that the major item or major combination includes all armament, equipment, accessories, and repair parts issued with the item. The technical service or manufacturer's part number is also included for reference.

e. Unit of Issue. This column lists the actual unit of issue for each item (ea, lg, ft, etc.).

f. Quantity Authorized. This column lists the quantity of the items authorized to fully equip one end item for troop use.

3. Explanation of Codes

a. Technical Service No. (Col. 2(a))

12—Adjutant General

b. Recoverability Code (Col. 2(d))

NR—Indicates an item that is nonexpendable and recoverable and is economically repairable.

Section II. BASIC ISSUE ITEMS LIST

(1) Illust		(2) Source, maint and recoverability code				(3)	(4)	(5)	(6)
(a) Fig No.	(b) Item No.	(a) Tech- nical service No.	(b) Source	(c) Main- te- nance level	(d) Re- cover- ability	Federal stock No.	Description	Unit of issue	Qty auth
							MAJOR ITEMS		
					NR	2330-395-1876	SEMITRAILER, LOW BED WRECKER; 12 TON, 4 WHEEL, W/E M269.		
					NR	2330-395-1877	SEMITRAILER, LOW BED WRECKER; 12 TON, 4 WHEEL, W/E M270.		
					NR	2330-289-7515	SEMITRAILER, LOW BED WRECKER; 12 TON, 4 WHEEL, W/E M270A1.		
							The following items of equipment are procured, stored and issued by technical services other than the Ordnance Corps, and issued initially with the vehicle. Replacements only will be requisitioned from the appropriate technical service in the usual manner, in accordance with current regulations.		
		12	-----	-----	-----	-----	FORM: DA Form 2407 EQUIPMENT MAINTENANCE LOG.....	1	
		12	-----	-----	-----	-----	MANUAL: TM 9-8240 OPERATOR, ORGANIZATIONAL AND FIELD MAINTENANCE MANUAL.	1	
		12	-----	-----	-----	-----	ORDER: LO 9-2330-220-12 LUBRICATION ORDER.....	1	

By Order of the Secretary of the Army:

EARLE G. WHEELER,
General, United States Army,
Chief of Staff.

Official:

J. C. LAMBERT,
Major General, United States Army,
The Adjutant General.

Distribution:

Active Army:

DCSLOG (1)	Proc Dist (1) except		
CNGB (1)	New York (5)		
USCONARC (3)	Cleveland (2)		
USAECOM (2)	Philadelphia (4)		
USAMICOM (2)	St Louis (3)		
USAMOCOM (2)	Chicago (None)		
USAMUCOM (2)	Plants (5) except		
USASMCOM (2)	Kingsbury (None)		
USAWECOM (2)	Ravenna, Pantex (2)		
ARADCOM (2)	Radford (1)		
ARADCOM Rgn (2)	Cen (2)		
OS Maj Comd (2)	USA Tk-Autmv Cen (135)		
OS Base Comd (2)	USAOSA (1)		
LOGCOMD (2)	Springfield Armory (2)		
Armies (3) except	POE (2)		
Sixth USA (1)	USA Trans Tml Comd (2)		
Corps (2)	Army Tml (2)		
Div (2)	PG (10)		
Instl (1) except Ft Belvoir,	Mil Msn (1)		
Ft Sam Houston, Ft Hood (7)	Units org under fol TOE's:		
Ft Bragg (2)	(2 copies each)		
Ft Sill (6)	5-367	9-137	55-469
Ft Meade (3)	5-464	9-167	55-477
Ft Bliss (9)	6-545	9-197	
Svc Colleges (2)	6-630	9-227	
Br Svc Sch (2) except	9-7	9-357	
USA Ord Sch (50)	9-9	9-377	
GENDEP (OS) (7)	9-12	9-500 (CA, CB)	
A Dep (1) except Black Hills,	9-25	17-48	
Savanna (5)	9-26	29-55	
Rossford (10)	9-27	29-75	
Sierra, Wingate, Umatilla (3)	9-47	29-79	
Sioux (2)	9-65	29-311	
San Jacinto (4)	9-66	39-61	
Dep (OS) (1)	9-67	55-18	
Arsenals (5) except Benicia,	9-76	55-457	
Frankford, Raritan (10)	9-87	55-459	
Joliet (4)	9-127	55-468	

NG: State AG (3); Units—same as Active Army except allowance is one copy to each unit.

USAR: None.

For explanation of abbreviations used, see AR 320-50.

This manual is correct to 5 July 1957

TM 9-8240/TO 36A9-9-3-21

TECHNICAL MANUAL DEPARTMENTS OF THE ARMY AND
No. 9-6240 THE AIR FORCE
TECHNICAL ORDER
No. 36A9-9-3-21 WASHINGTON, D. C., 23 August 1957

**12-TON, 4-WHEEL WRECKER LOW-BED SEMITRAILERS
M269, M270, AND M270A1**

	Paragraphs	Page
CHAPTER 1. INTRODUCTION		
Section I. General.....	1-3	3-13
II. Description and data.....	4-18	13-42
CHAPTER 2. OPERATING INSTRUCTIONS		
Section I. Service upon receipt of materiel.....	19-22	43-44
II. Controls and operation.....	23-31	44-51
III. Operation under unusual conditions.....	32,33	51-55
CHAPTER 3. ORGANIZATIONAL MAINTENANCE INSTRUCTIONS		
Section I. Parts, special tools, and equipment for or- ganizational maintenance.	34-37	56, 57
II. Lubrication and painting.....	38-40	57-64
III. Preventive-maintenance service.....	41-44	64-73
IV. Troubleshooting.....	45-50	73-79
V. Wheels, tires, hubs, and brake drums.....	51-53	79-86
VI. Suspension.....	54-55	86-89
VII. Brakes.....	56-67	90-104
VIII. Landing gear and spare wheel and tire carrier.	68-70	104-108
IX. Electrical system.....	71-75	108-113
X. Frame, body, and equipment.....	76-77	113-114
CHAPTER 4. FIELD AND DEPOT MAINTENANCE INSTRUCTIONS.		
Section I. Parts, special tools, and equipment for field and depot maintenance.	78-81	115
II. Repair and rebuild of wheels, hubs, and brake drums.	82-84	115-119
III. Rebuild of axles, springs, and tube, with brackets, assembly.	85-89	119-133
IV. Repair and rebuild of brakes and brake system components.	90-98	133-138
V. Rebuild of landing gear, stowage box, stow- age compartment, and tire carrier.	99-103	138-153

VI. Rebuild of electrical system	104, 105	154-161
VII. Repair and rebuild of frame	106, 107	161, 162
VIII. Repair and rebuild of deck and stakes	108, 109	162
IX. Repair and rebuild standards	110-113	162-164
 CHAPTER 5. SHIPMENT AND STORAGE AND DE- STRUCTION OF MATERIEL TO PRE- VENT ENEMY USE		
Section I. Domestic shipment and limited storage	114-118	165-169
II. Destruction of materiel to prevent enemy use.	119-122	169-173
APPENDIX REFERENCES		174-178
INDEX		179-184

CHAPTER 1

INTRODUCTION

Section I. GENERAL

1. Scope

a. This manual contains instructions for operation and organizational maintenance of the 12-ton 4-wheel wrecker low-bed semitrailers M270A1 (figs. 1, 4, and 7), M270 (figs. 2 and 5), and M269 (figs. 3, 6, and 8) for the using organization, and instructions for field and depot maintenance for ordnance maintenance personnel.

b. The appendix contains a list of current references, including supply manuals, technical manuals, and other available publications applicable to the materiel.

c. TM 9-1827C contains repair and rebuild instructions on the M270A1 brake mechanism and master cylinder. TM 9-1827A and TM 9-8601 contain repair and rebuild instructions on the air chambers, check valves, emergency relay valves, and air filters.

d. This first edition is published in advance of complete technical review. Any errors or omissions will be brought to the attention of Chief of Ordnance, Headquarters, Department of the Army, Washington 25, D. C. ATTN: ORDFM-Pub.

2. Maintenance Allocation

a. *Organizational Maintenance Allocation.* In general, the prescribed organizational maintenance responsibilities will apply as reflected in the allocation of tools and supply parts in the appropriate columns of the current ORD 7 supply manual pertaining to this materiel and in accordance with the extent of disassembly prescribed in this manual for the purpose of cleaning, lubricating, or replacing authorized spare parts. In all cases where the nature of the repair, modification, or adjustment is beyond the scope or facilities of the using organization, the supporting ordnance maintenance unit should be informed in order that trained personnel with suitable tools and equipment may be provided or other proper instructions issued.

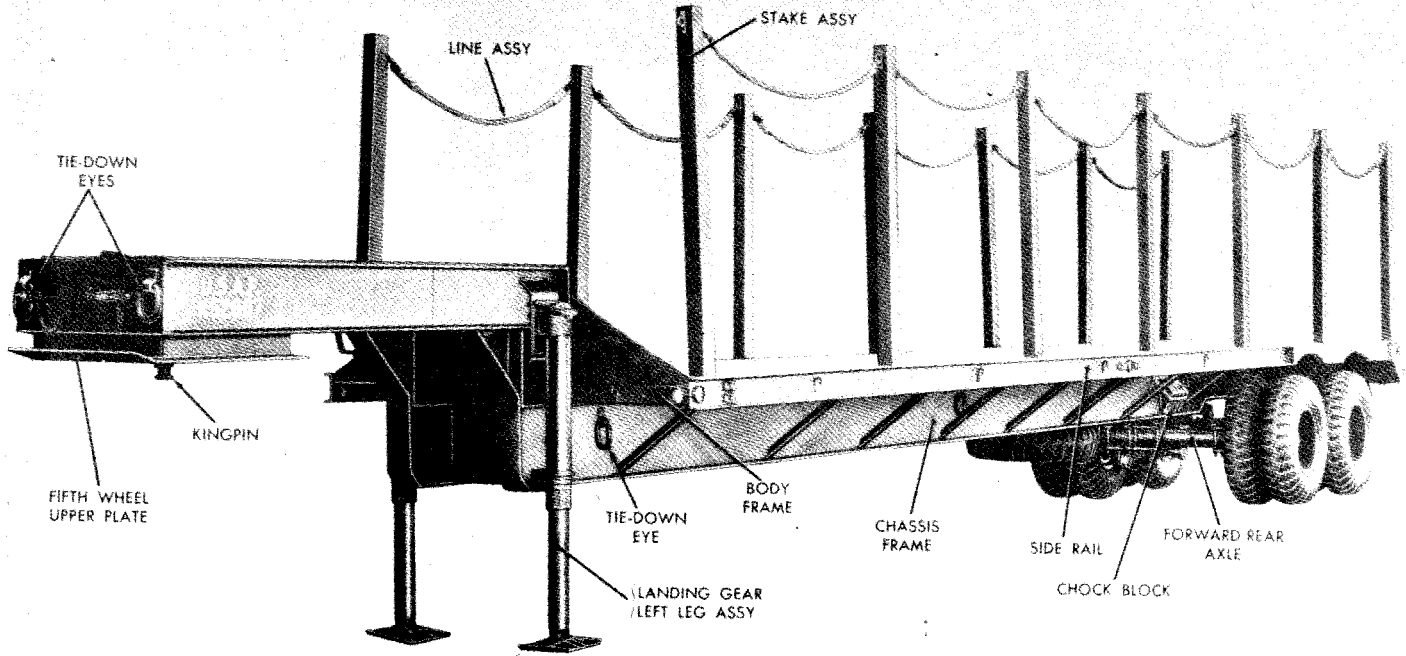

Figure 1. Wrecker low-bed semitrailer M270A1—left-front view.

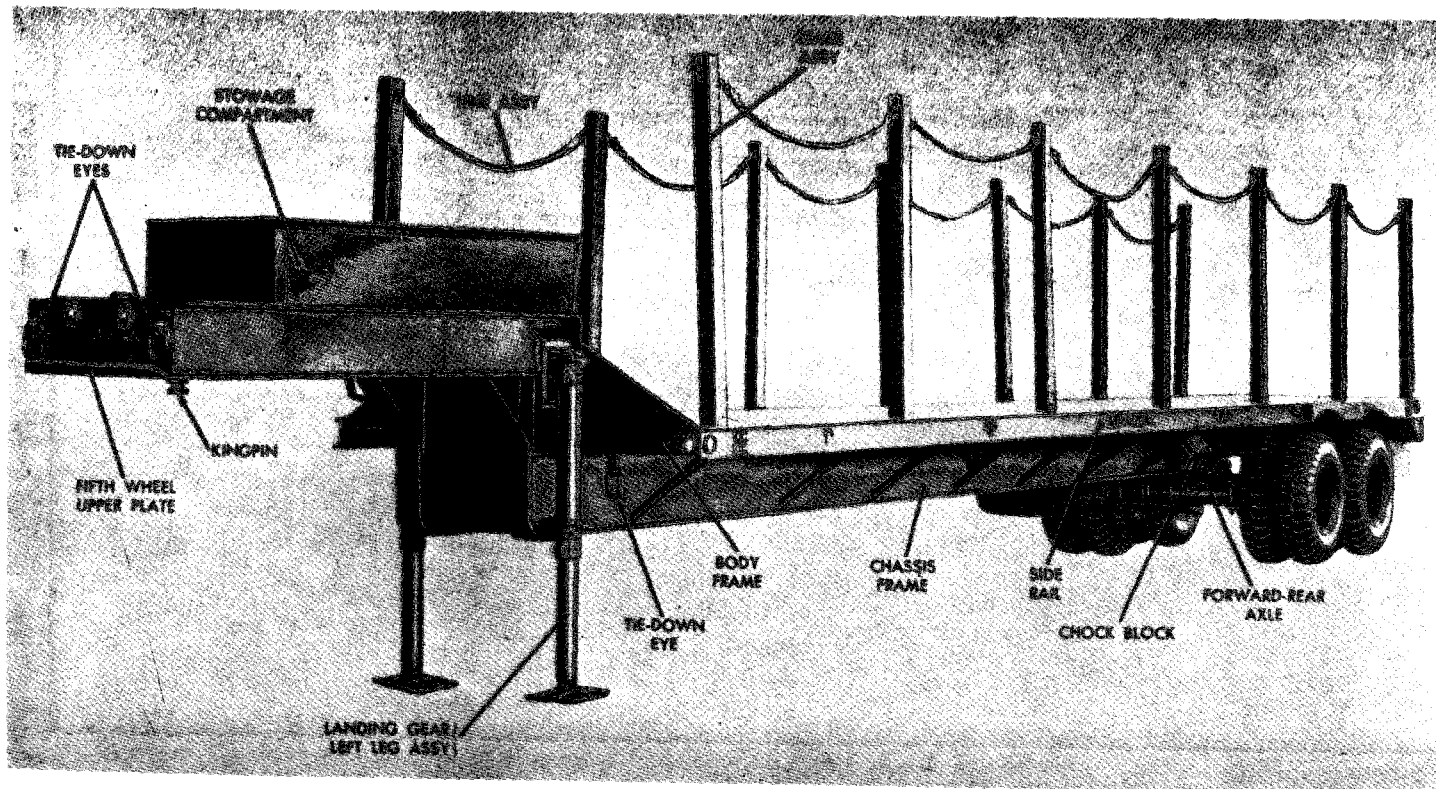
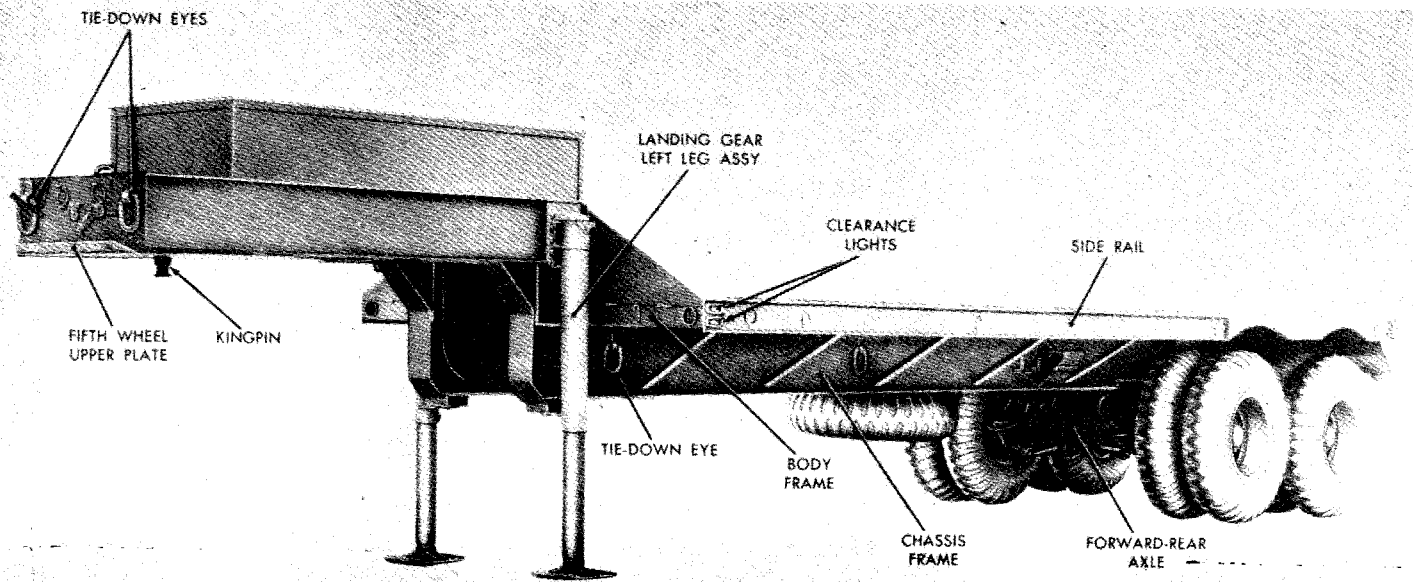

Figure 2. Wrecker low-bed semitrailer M270—left-front view.



RA PD 370R17

Figure 3. Wrecker low-bed semitrailer M269—left-front view.

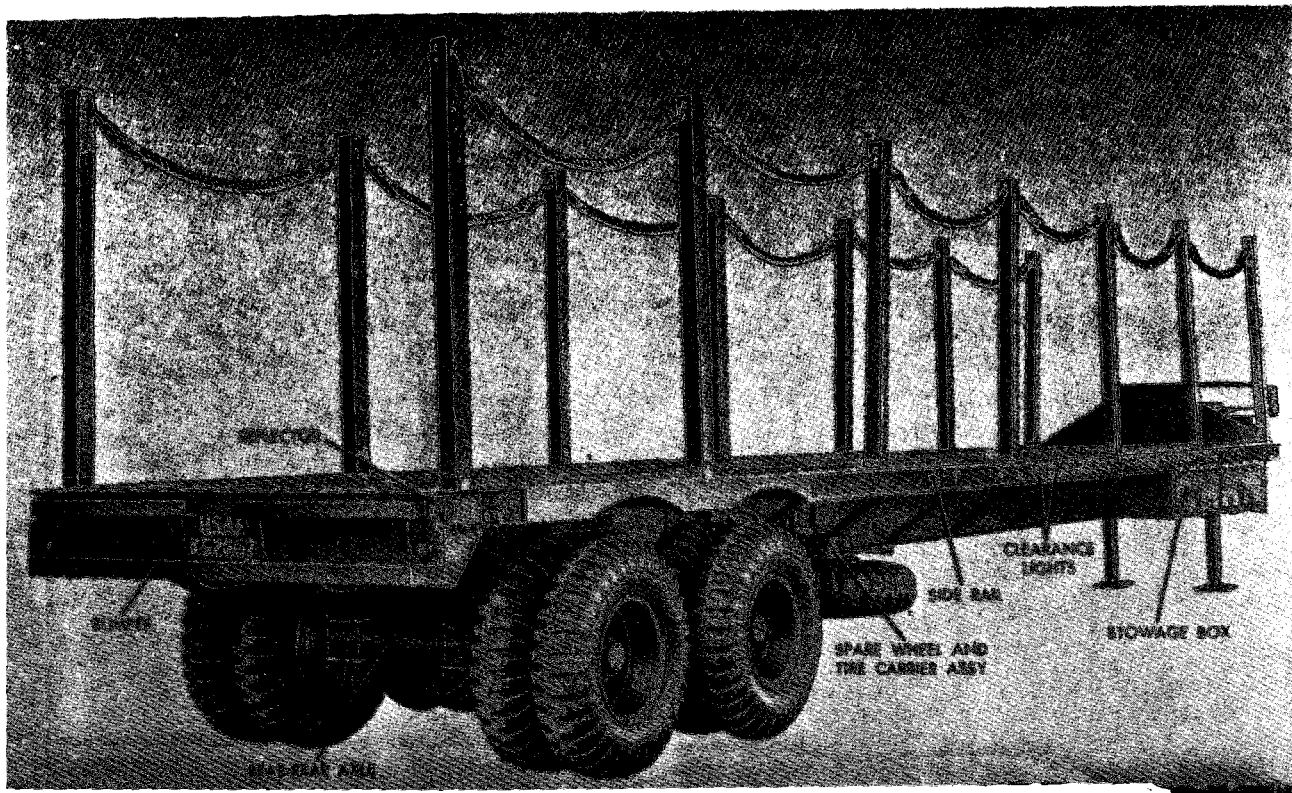

Figure 4. Wrecker low-bed semitrailey M270A1—right-rear view.

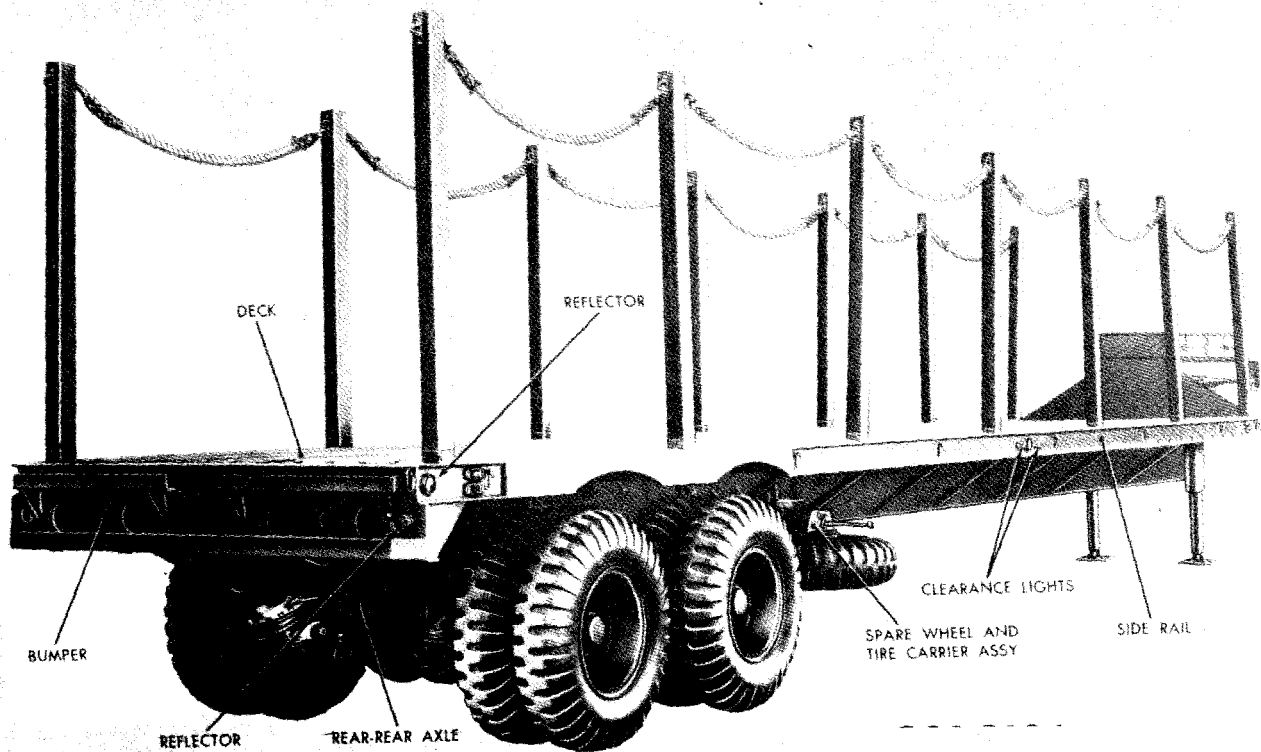

Figure 5. Wrecker low-bed semitrailer M270—right-rear view.

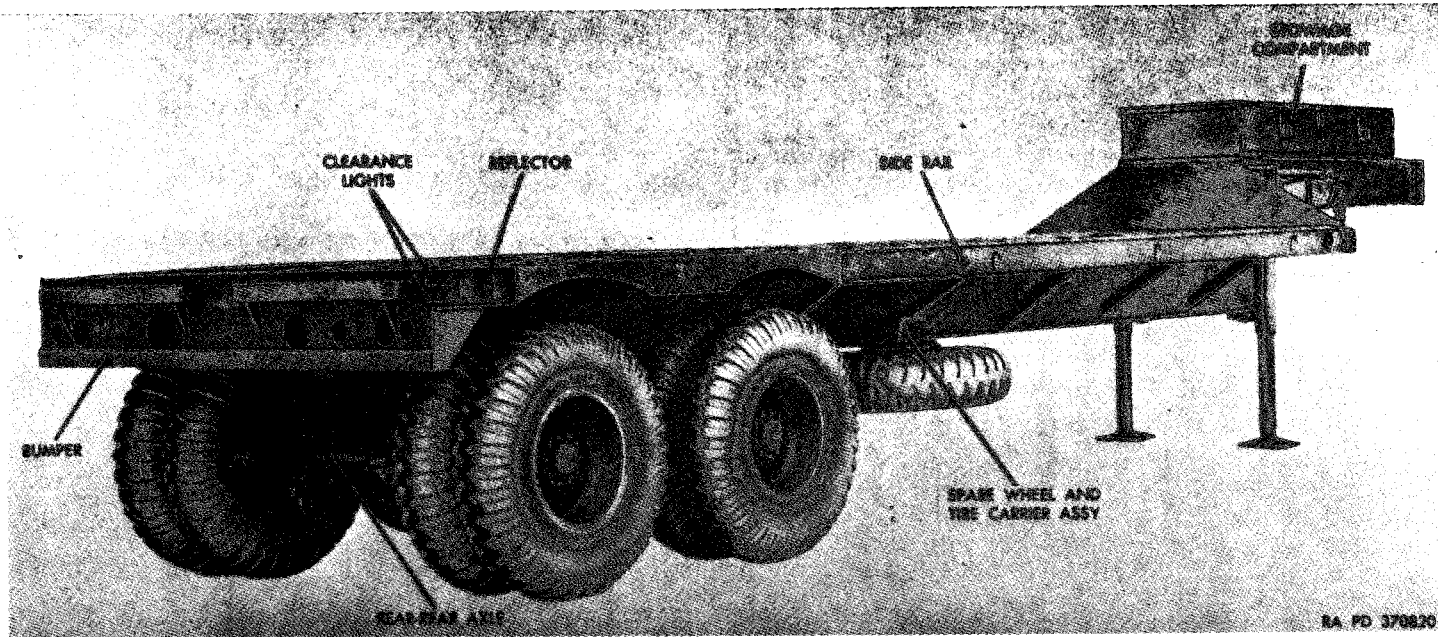

Figure 6. Wrecker low-bed semitrailer M269—right-rear view.

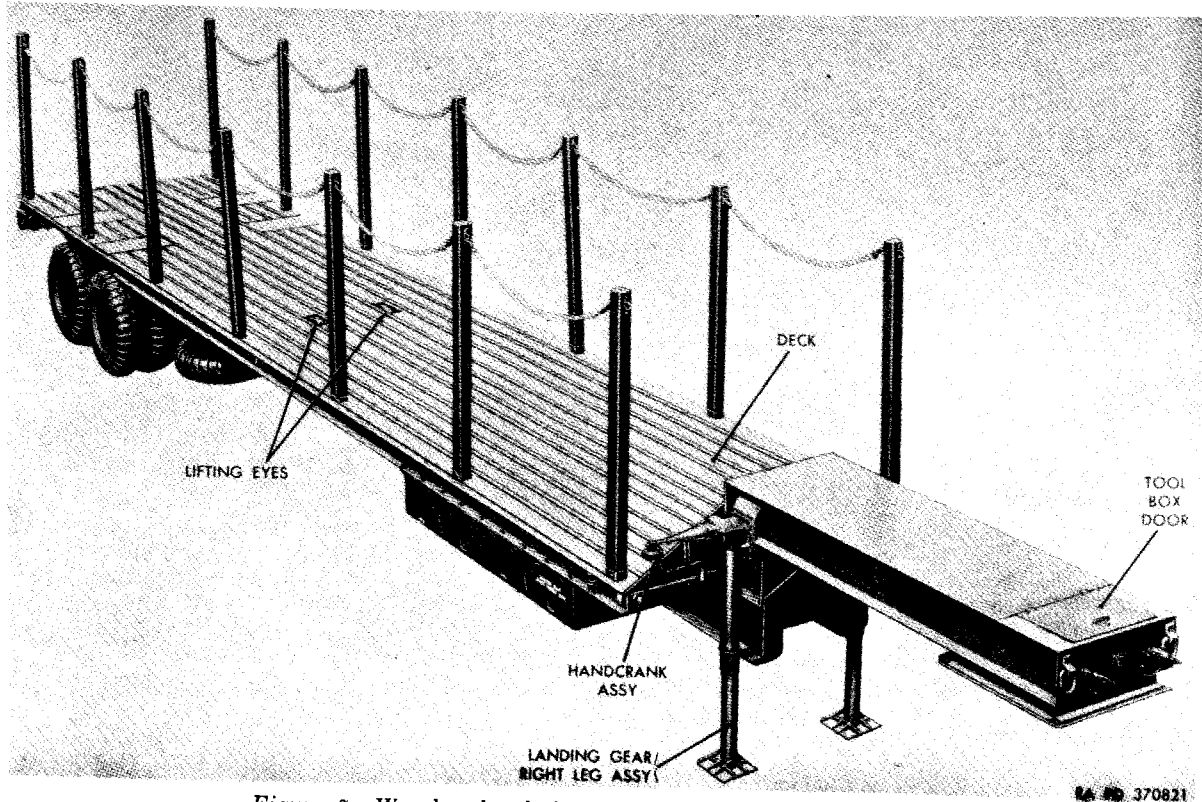

Figure 7. Wrecker low-bed semitrailer M270A1—top view.

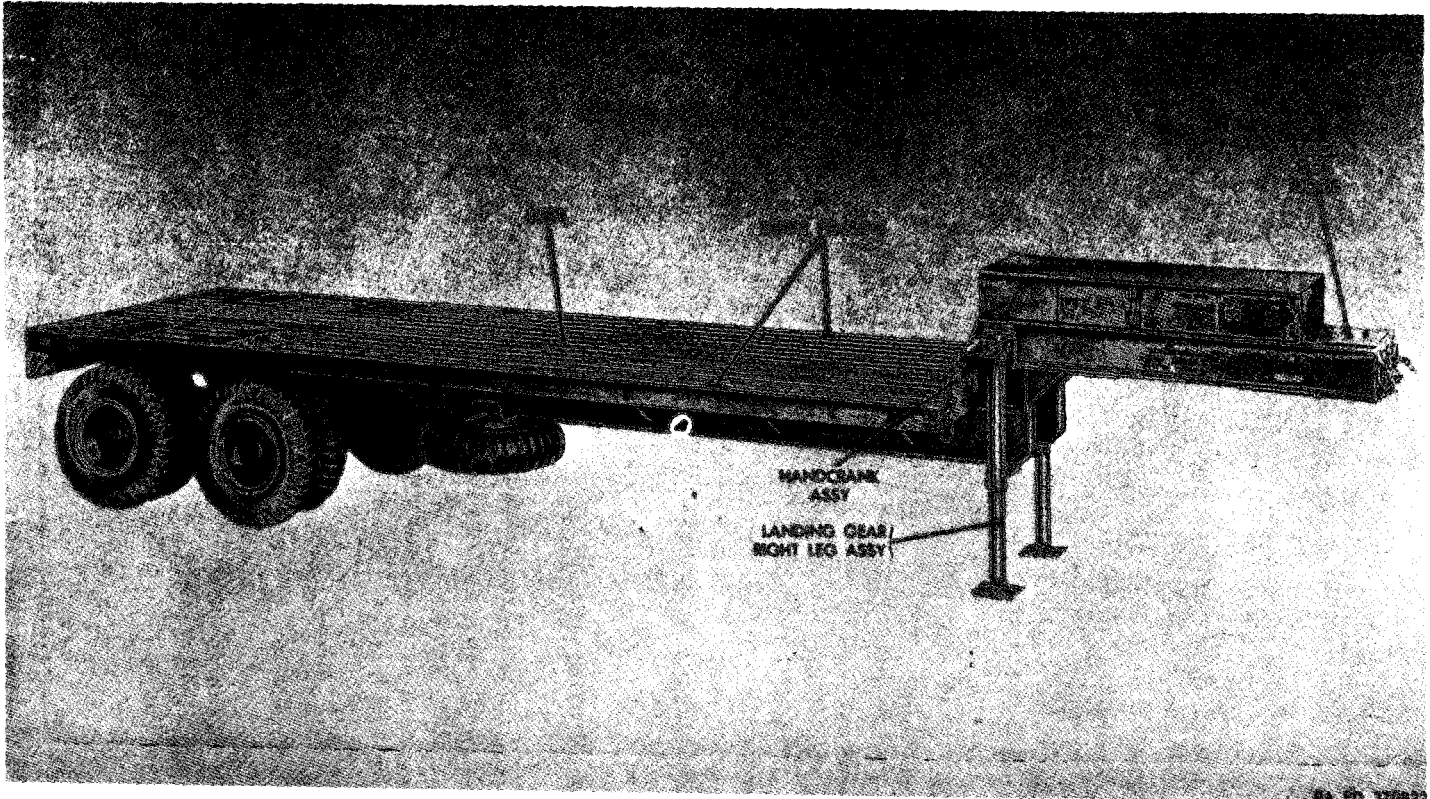

Figure 8. Wrecker low-bed semitrailer M269—top view.

Note. In cases of emergency and with prior approval of the supporting ordnance officer, the using organization may replace certain assemblies, such as axles, trunnion cross tube, and springs which are normally replaced by ordnance maintenance units. Replacement assemblies, necessary tools not carried by the using organization, special instructions regarding the assembly and associated accessories, etc., may be obtained from the supporting ordnance maintenance unit.

b. Field and Depot Maintenance Allocation. The publication here in of instructions for complete disassembly and rebuild is not to be construed as authority for the performance by field maintenance units of those functions which are restricted to depot shops and arsenals. In general, the prescribed maintenance responsibilities will be reflected in the allocation of maintenance parts listed in the appropriate columns of the current ORD 8 supply manual pertaining to this materiel. (When the ORD 8 supply manual is not available, the field and depot maintenance allocation may be determined in accordance with chapter 4 of this manual.) Instructions for depot maintenance are to be used by maintenance companies in the field only when the tactical situation makes the repair functions imperative. Supply of parts listed in the depot guide column of ORD 8 supply manuals will be made to field maintenance only when the emergency nature of the maintenance to be performed has been certified by a responsible officer of the requisitioning organization.

3. Forms, Records, and Reports

a. General. Responsibility for the proper execution of forms, records, and reports rests upon the officers of all units maintaining this equipment. However, the value of accurate records must be fully appreciated by all persons responsible for their compilation, maintenance, and use. Records, reports, and authorized forms are normally utilized to indicate the type, quantity, and condition of materiel to be inspected, repaired, or used in repair. Properly executed forms convey authorization and serve as records for repair or replacement of materiel in the hands of troops and for delivery of materiel requiring further repair to ordnance shops in arsenals, depots, etc. The forms, records, and reports establish the work required, the progress of the work within the shops, and the status of the materiel upon completion of its repair.

b. Authorized Forms. The forms generally applicable to units operating and maintaining this equipment are listed in the appendix., For a listing of all forms, refer to DA Pam 310-2. For instructions on use of these forms, refer to FM 9-10.

c. *Field Reports of Accidents.* The reports necessary to comply with the requirements of the Army safety program are prescribed in detail in SR 385-10-40. These reports are required whenever accidents involving injury to personnel or damage to materiel occur.

d. *Report of Unsatisfactory Equipment and Materiels.* Any deficiencies detected in the equipment covered herein which occur under the circumstances indicated in AR 700-38 should be immediately reported in accordance with the applicable instructions in those regulations.

Section II. DESCRIPTION AND DATA

4. Description

a. General.

- (1) The 12-ton 4-wheel wrecker low-bed semitrailers M270A1 (figs. 1, 4, and 7), M270 (figs. 2 and 5), and M269 (figs. 3, 6, and 8) are designed to be towed by the 5 ton 6 x 6 truck tractor M52 or similar vehicle equipped with fifth wheel (lower coupler).
- (2) Each semitrailer has two axles at the rear mounted on a leaf-spring suspension. A fifth wheel upper plate (figs. 1-3) under the front end or nose of the semitrailer includes a kingpin which is fitted into the fifth wheel on a towing vehicle to permit the semitrailer to be towed. A foot-type landing gear (retractable support) (figs. 1-3) supports the front end of the semitrailer when not coupled to a towing vehicle.
- (3) Each semitrailer is equipped with two chock blocks (fig. 14) to prevent rolling when parked. Each chock block is chained to the chassis frame to prevent loss. When not in use, chains and blocks are carried in brackets welded to the chassis frame beams near the rear end.
- (4) The spare tire is carried on a winch-type spare wheel and tire carrier assembly (figs. 4-6) under the right side of the chassis frame. A tool box, of which the tool box door (figs. 7 and 8) is part, is provided between the chassis frame beams at the front end or nose of the semitrailer, directly over the fifth wheel upper plate.
- (5) Lights on each semitrailer are supplied with current by and operated from the towing vehicle.

b. *Semitrailer M270A1.*

- (1) Semitrailer M270A1 has been designed to be towed

over prepared roads with loads to 20 tons at speeds to 50 miles per hour and to be towed over unimproved roads, trails, and open rolling terrain with loads to 12 tons at speeds to 30 miles per hour.

- (2) The air-over-hydraulic operated brake mechanism (fig. 15) is controlled from the towing vehicle.
- (3) A stowage box (fig. 4) is provided beneath the body frame at the right front of the semitrailer.

c. Semitrailers M270 and M269.

- (1) Semitrailers M270 and M269 have been designed to be towed over prepared roads with loads to 18 tons at speeds to 50 miles per hour and to be towed over unimproved roads, trails, and open rolling terrain with loads to 12 tons at speeds to 30 miles per hour.
- (2) The air operated brake mechanism (par. 10j (2)) is controlled from the towing vehicle.
- (3) A stowage compartment (figs. 2 and 6) is mounted on top of the nose or front end of the chassis frame above and to the rear of the fifth wheel upper plate.

5. Differences Among Models

a. General. Semitrailers M270A1 (figs. 1, 4, and 7), M270 (figs. 2 and 5), and M269 (figs. 3, 6, and 8) may be identified by differing external and minor internal characteristics. Specific differences in models are described in b, c, and d below. Refer to paragraph 10 for detailed description of wheel brakes and brake systems.

b. Chassis Frame and Body Frame. While the construction of the chassis and body frame of each vehicle is basically the same, they differ in overall length. The frame of semitrailer M270A1 is longer than the frames of semitrailers M270 and M269. Refer to paragraph 18 for relative dimensions.

c. Brake Systems.

- (1) *Semitrailer M270A1.* The semitrailer is equipped with an air-over-hydraulic brake system (fig. 10). For a detailed description of the brake system, refer to paragraph 10i (1).
- (2) *Semitrailers M270 and M269.* Each semitrailer is equipped with an air brake system (fig. 11). For a detailed description of the air brake system, refer to paragraph 10i (2).

d. Wheel Brakes.

- (1) *Semitrailer M270A1.* The semitrailer is equipped with four hydraulically operated, self-centering, FR2S-type

wheel brake assemblies. For a detailed description of the wheel brakes, refer to paragraph 10k (l),.

- (2) *Semitrailers M270 and M269.* Each semitrailer is equipped with four S-cam, two-shoe, double anchor, expanding-type wheel brake assemblies. For a detailed description of wheel brakes, refer to paragraph 10k (2).

e. *Taillights.*

- (1) *Semitrailer M270A1.* A blackout stoplight is located at the right rear of the vehicle and is attached to a bracket welded to the rear cross member of the chassis frame. A service tail and stop and blackout and turn indicator taillight is located on the left rear and right rear of the vehicle. Each taillight is mounted on a bracket welded to a chassis frame longitudinal beam. All taillights are positioned behind circular openings in the rear cross member.
- (2) *Semitrailers M270 and M269.* A blackout stoplight is located at the right rear of the vehicle and is attached to a bracket welded to the rear cross member of the chassis frame. A service tail and stop and blackout taillight is located at the right rear and left rear of the vehicle. Each taillight is attached to a bracket welded to a chassis frame longitudinal beam. A directional light is located at the right rear and left rear of the vehicle. Each directional light is attached to a bracket welded to the rear cross member of the chassis frame. All taillights are positioned behind circular openings in the rear cross member.

f. *Reflectors.*

- (1) *Semitrailers M270A1 and M270.* Two red reflectors are located at the rear of the vehicle in addition to the one on left side and one on right side toward the rear of the vehicle. Six amber reflectors, three on each side, are located at the center, at the front, and toward the front of the vehicle.
- (2) *Semitrailer M269.* Two red reflectors are located at the rear of the vehicle in addition to the one on left side and one on right side toward the rear of the vehicle. Four amber reflectors, two on each side, are located at the front and toward the front of the vehicle.

g. *Clearance Lights.*

- (1) *Semitrailers M270A1 and M270.* Two red blackout

clearance lights (figs. 4 and 5) one on each side, are located toward the rear of the vehicle. Two red service clearance lights, one on each side, are located toward the rear of the vehicle, directly below the red blackout clearance lights. Four amber blackout clearance lights, two on each side, are located at the center and toward the front of the vehicle. Four amber service clearance lights, two on each side, are located at the center and toward the front of the vehicle.

- (2) *Semitrailer M269*. Two red blackout clearance lights (fig. 6), one on each side, are located toward the rear of the vehicle. Two red service clearance lights, one on each side, are located toward the rear of the vehicle, directly below the red blackout clearance lights. Two amber blackout clearance lights, one on each side, are located towards the front of the vehicle. Two amber service clearance lights, one on each side, are located towards the front of the vehicle, directly below the amber blackout clearance lights.

h. Intervehicular Cable Receptacles and Sockets.

- (1) *Semitrailer M270A1*. A 24-volt intervehicular receptacle assembly (fig. 29), located at the front end or nose of the vehicle, is attached to the front cross member of the chassis frame.
- (2) *Semitrailers M270 and M269*. A 24-volt intervehicular receptacle assembly (fig. 28), 12-volt socket assembly, and 6-volt socket assembly, located at the front end or nose of the vehicle, are attached to the front cross member of the chassis frame.

6. Chassis Frame and Body Frame

a. The chassis frame is of welded construction with drop-frame i-section, longitudinal beams, and intermediate cross members. Raised and extended sections of beams are welded to the forward ends of the longitudinal beams to form the front end or nose of "the vehicle. These beams are strengthened with cross members, plates, and reinforcements. Mounting brackets for the tandem axle spring suspension are riveted to the outer side and underside of the longitudinal beams.

b. The body frame (figs. 1-3) is of welded construction with structural steel side rails, pressed steel cross members, supports, outriggers, and short cross members. The short cross members and outriggers are used to provide support for the plates covering the wheel housing openings of the body frame.

c. The chassis frame and body frame are welded together into an integral unit with the cross members of the body frame being welded to the tops of the long longitudinal beams of the chassis frame. Braces welded to the cross members of the body frame and the beams of the chassis frame provide additional support for the body frame.

d. The fifth wheel upper plate (figs. 1-3) is welded to the underside of the raised and extended beams (front) of the chassis frame. It is backed by two reinforcements at the center of the plate and two channel reinforcements along its sides. The kingpin (figs. 1-3) extends through and is welded to the plate.

e. Eight tie-down eyes are welded to the outside of the chassis frame to permit the vehicle to be secured to its carrier in shipment. Eight lifting eyes, two welded to the front cross member of the body frame, four welded to supports at the center of the frame, and two welded to the rear cross member of the frame, are provided for lifting the body frame.

f. Stake pockets (fig. 8) are located on the inside of the body frame side rails. Pockets are provided for seven stake assemblies (M270A1 and M270), or six stake assemblies (M269), on each side of the body frame. A rear member assembly, welded to the rear of the chassis frame and body frame, contains two channel bumpers and two hinged shields.

7. Deck

(figs. 5, 7, and 8)

a. The hardwood deck is made up of 1¾-inch thick deck planks which are fastened directly to the body frame.

b. Planks are fastened directly to outriggers, supports, and cross members of the body frame with bolts, nuts, and lock washers. Edges of each plank are countersunk for metal strips which overlap the edges of adjoining planks.

8. Stakes

(figs. 1 and 2)

Hardwood stakes fit in stake pockets welded to the inside of the body frame outer rails. Each stake has two overlapping steel stake shoes secured to its lower end, and two chain loops secured to its upper end. The loops are provided for securing the link assembly between stakes. Each stake is 78 inches high.

9. Suspension

(fig. 9)

a. Springs.

- (1) The springs are of semielliptic type with 12 leaves held together by a center bolt and two small and two large leaf clips. The center bolt end is peened over its hex nut to prevent it from coming loose. Two leaf clips are riveted to the fifth and ninth leaf. Each clip is closed at the top by a hex-head bolt which passes through the clip and a clip spacer, and is held by a hex nut over which the bolt end has been peened.
- (2) The ends of the spring seat in spring guide brackets are secured to the axles. The center of the spring seats in, and is clamped to, the spring seat assembly which is secured to the tube with brackets assembly (trunnion cross tube).
- (3) A U-bolt on each side of the spring hold the spring in position. The U-bolts fit over a spring saddle on top of the spring, down the sides of the spring and through the spring seat assembly and are secured with lockwashers and double nuts.

b. *Axle.* The tubular axle has six adapters and two flanges welded to its external surface. Adapters provide seating surfaces for spring guide brackets, torque rod brackets, and torque rod bracket mounting brackets. Flanges are provided for mounting brake backing plates to the axle.

c. *Torque Rods.* Two torque rods are attached beneath each axle and one is attached above each axle. The torque rods beneath each axle are attached at one end to brackets attached to the axle and at the other end to brackets extending from the tube, with brackets, assembly (trunnion cross tube). The torque rod above each axle is attached at one end to brackets attached to the axle and at the other end to a bracket riveted to the chassis frame left longitudinal beam. Each torque rod is retained in its brackets by two slotted hex nuts and cotter pins.

d. *Tube, with Brackets, Assembly (Trunnion Cross Tube).* The tube, with brackets, assembly is attached to brackets welded to the longitudinal beams of the chassis frame at a point midway between the forward-rear and rear-rear axle. A spring seat on each end of the tube, with brackets, assembly is mounted on roller bearing similar to those on the hubs of the wheels.

10. Brakes

a. *General.* When the brake system of the semitrailer is

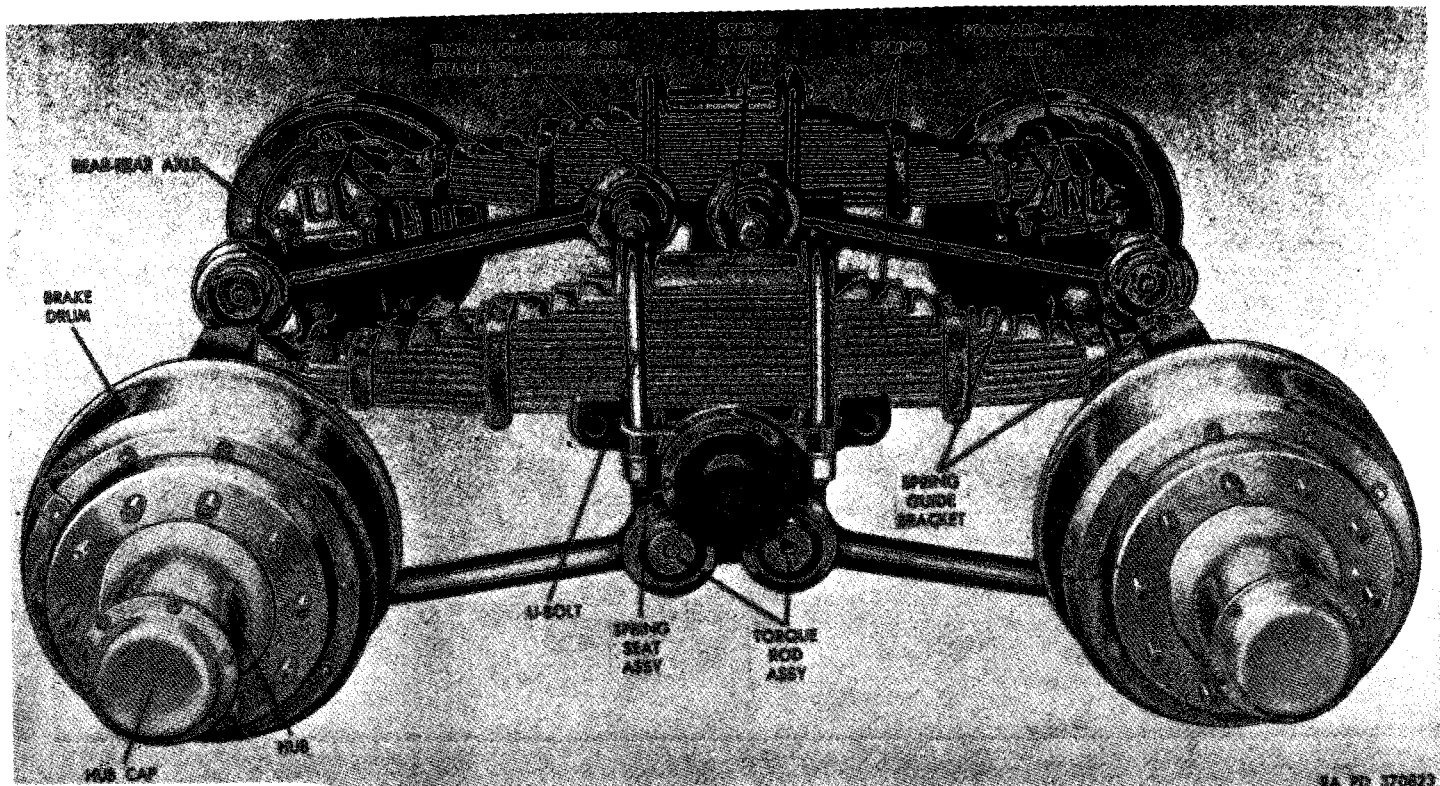

Figure 9. Suspension—semitrailer M270A1.

properly connected to the service brake system of the towing vehicle, the service brake pedal on the towing vehicle controls the brakes on both vehicles. To produce and maintain a constant supply of compressed air to actuate and operate the semitrailer brakes, the towing vehicle is equipped with an air compressor, reservoirs which store a supply of compressed air, a governor for controlling the compression of air, an air gage for showing the pressure of air in the system, a safety valve to insure against excessive pressure, and air lines, air hose couplings, air hose, and shutoff cocks to convey compressed air to the brake system on the semitrailer.

Note. Although these units are located on the towing vehicle, all must operate effectively to insure proper performance of the semitrailer brakes.

b. Operation of Semitrailer Brakes.

(1) *Filling air reservoir.* When the air brake hoses for the service and emergency air lines are connected between the towing vehicle and the semitrailer and the air shutoff cocks on the towing vehicle are opened, air flows through the emergency air line, air cleaner filter, and emergency relay valve to fill the air reservoir on the semitrailer. Air pressure is built up to equal the pressure in the compressed air system of the towing vehicle.

(2) *Applying semitrailer brakes.*

(a) *Semitrailer M270A1* (fig. 10). When foot pressure is applied to the brake pedal of the towing vehicle, air pressure is directed through the service air line to the emergency relay valve on the semitrailer. Through connecting lines, the emergency relay valve releases compressed air from the air reservoir to each brake air chamber. A diaphragm and push rod in each air chamber, when under air pressure, moves a piston in each hydraulic master cylinder. Hydraulic fluid present in the body of each master cylinder is forced into the wheel brake cylinders for a brake application.

(b) *Semitrailers M270 and M269* (fig. 11). When foot pressure is applied to the foot pedal of the towing vehicle, air pressure is directed through the service air line to the emergency relay valve mounted on and connected to the air reservoir on the semitrailer. The emergency relay valve causes compressed air to be released from the air reservoir to brake air chambers to which are attached slack adjusters on

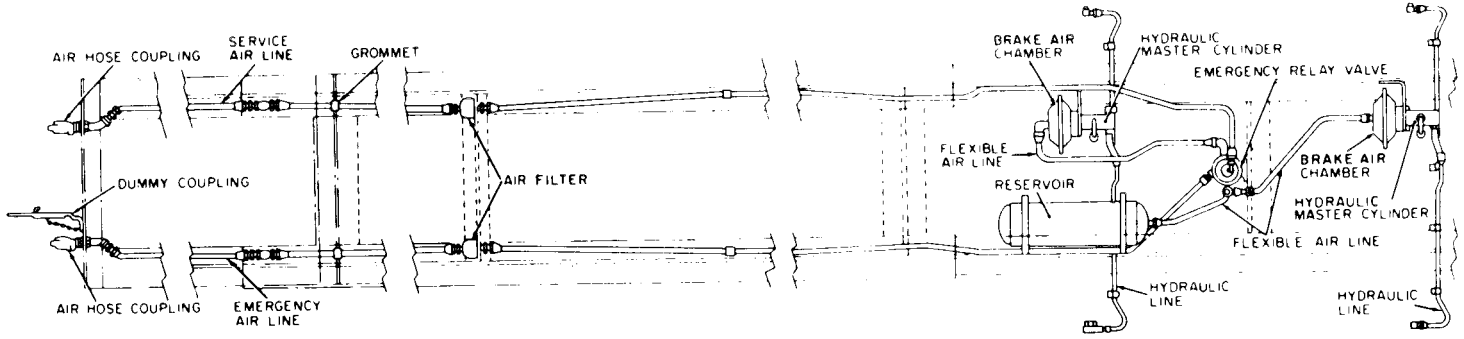

RA PD 370825

Figure 10. Schematic diagram of brake system—semitrailer M270A1.

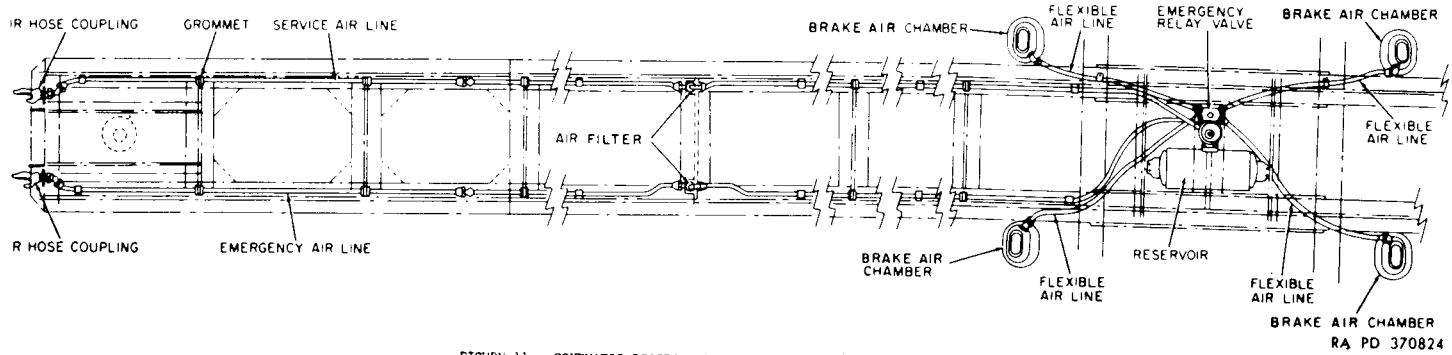

FIGURE 11. SCHEMATIC DIAGRAM OF BRAKE SYSTEM - SEMITRAILERS M270 AND M269

Figure 11. Schematic diagram of brake system—semitrailers M270 and M269.

the camshafts of each wheel brake mechanism. The action of the air chambers causes the slack adjusters to rotate the camshafts, forcing the brake shoes into contact with the brake drums for a brake application.

- (3) *Releasing semitrailer brakes.* When the brake pedal of the towing vehicle is released, a drop in pressure in the service air line causes the emergency relay valve to release the compressed air from the brake air chambers. This release of pressure permits springs in the air chambers and wheel brake mechanisms to pull the brake shoes away from the drums. The extent of brake release, like the amount of brake application, is in direct proportion to the movement of the brake pedal on the towing vehicle.

c. Emergency Relay Valve Assembly. The emergency relay valve assembly (fig. 12), on semitrailers M270 and M269, is mounted on the semitrailer air reservoir. The emergency relay valve assembly (fig. 13), on semitrailer M270A1, is mounted on a cross member of the chassis frame at a point above and between the axles. The valve assembly performs the same basic function on all vehicles. It directly controls the service brakes on the semitrailer. It speeds brake action by releasing air from the reservoir on the semitrailer directly to the brake air chambers, eliminating the loss of time that would result if sufficient air to operate the brakes had to travel from a reservoir on the towing vehicle to the semitrailer brake air chambers. In addition, this valve assembly controls the flow of air to and from the semitrailer air reservoir and its automatically applies the brakes in the event that the semitrailer breaks away from the towing vehicle or there is a serious leak in the emergency air line.

d. Service Air Line. The service air line (figs. 12 and 13) on the semitrailer extends from the air hose coupling (tagged SERVICE) on the right side of the front cross member, along the right chassis frame beam to an elbow in the top of the emergency relay valve. Its purpose is to transmit changes in air pressure which cause this valve to function. The changes in pressure result from the brake control on the towing vehicle being operated and the changes are dictated by the extent to which the control is applied or released.

e. Emergency Air Line. The emergency air line (figs. 12 and 13) on the semitrailer extends from its air hose coupling (tagged EMERGENCY), along the inside of the left chassis

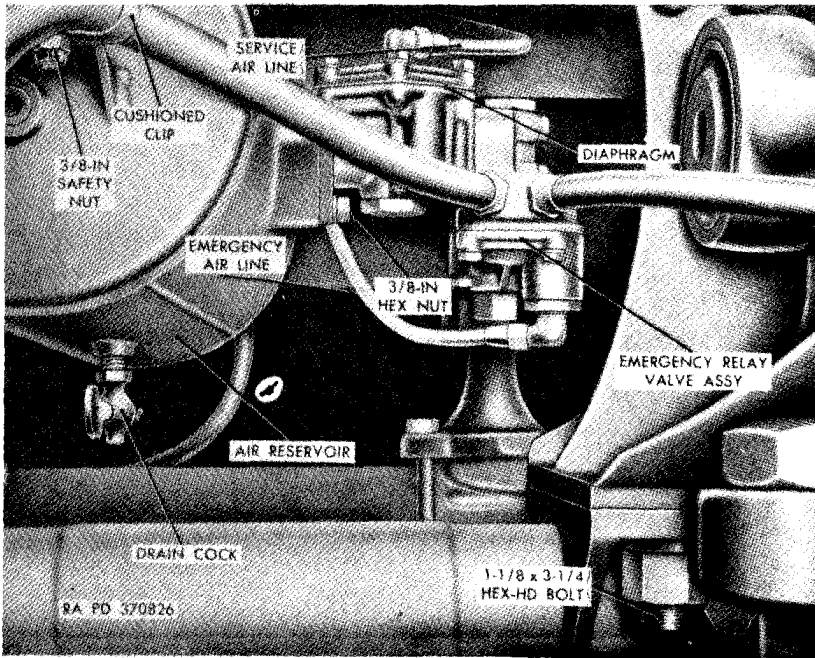

Figure 12. Emergency relay valve, air reservoir, and lines—semitrailers M270 and M269.

frame beam, to a threaded opening near the bottom of the emergency relay valve. It transmits compressed air to fill the semitrailer reservoir and to maintain the proper air pressure. under the control of the emergency relay valve, to apply the brakes of the semitrailer.

f. *Air Filters.* Air filters (figs. 10 and 11) are connected into the service and emergency air lines and are secured to chassis frame cross members by U-bolts. Their purpose is to remove any moisture) or foreign matter from the air passing through them. The air filters are fitted with removable elements, held in Place by spring washers and springs. The filter element is removed by unscrewing the nut at the base of the cleaner body. The nut is fitted with a plug which is removed to drain accumulations of moisture.

(g. *Air Reservoir.* The air reservoir (figs. 12 and 13) is a metal tank mounted on brackets attached to the chassis frame between the) suspension mounting brackets. It is connected by a tube to the emergency relay valve. The reservoir provides a supply of air. on the semitrailer for applying the brakes. It is equipped with a drain cock for draining accumulations of moisture and for releasing air pressure in the semitrailer brake

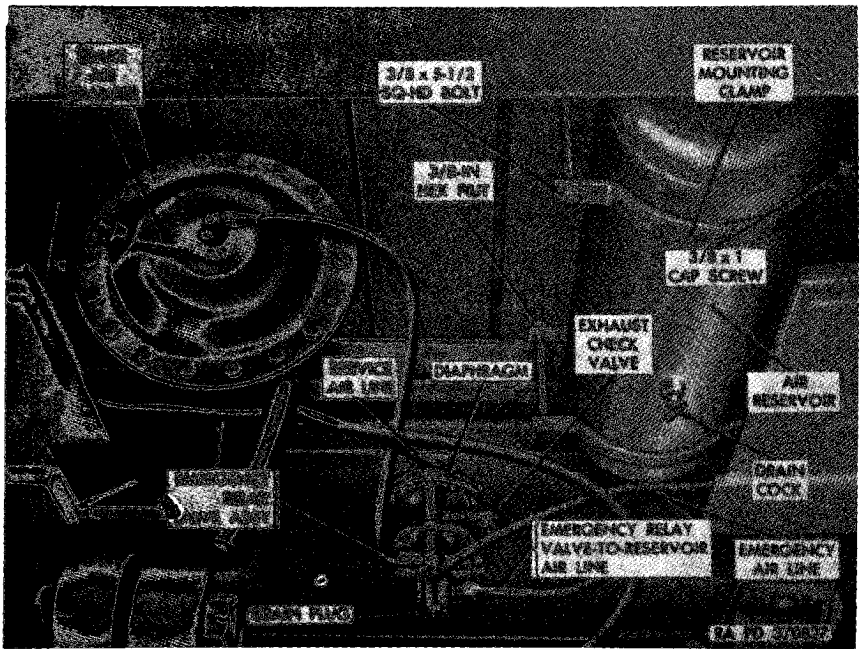

Figure 13. Emergency relay valve, air reservoir, and lines—semitrailer M270A1.

system in the event of locked brakes.

h. Chock Blocks. Chock blocks (fig. 14) are provided to be placed in back of, or in front of, the semitrailer Wheels as required to hold the vehicle stationary when parked on an incline or when it is to be coupled or uncoupled. The chock blocks are made of triangular layers of wood (laminae) bolted together. The chock blocks are chained to the chassis frame beams to prevent loss and chains and blocks are carried in brackets when not in use.

i. Types of Brakes.

- (1) *Semitrailer M270A1.* The brakes are of the air-over-hydraulic type. Two brake hydraulic master cylinders, with air chambers attached, provide the means for converting the energy of compressed air into hydraulic pressure necessary to operate the hydraulically actuated semitrailer wheel brakes.
- (2) *Semitrailers M270 and M269.* The brakes are of the air-actuated type. Air pressure is used to operate the mechanical brake mechanisms at the semitrailer wheels, applying the brakes with pressure in proportion to the

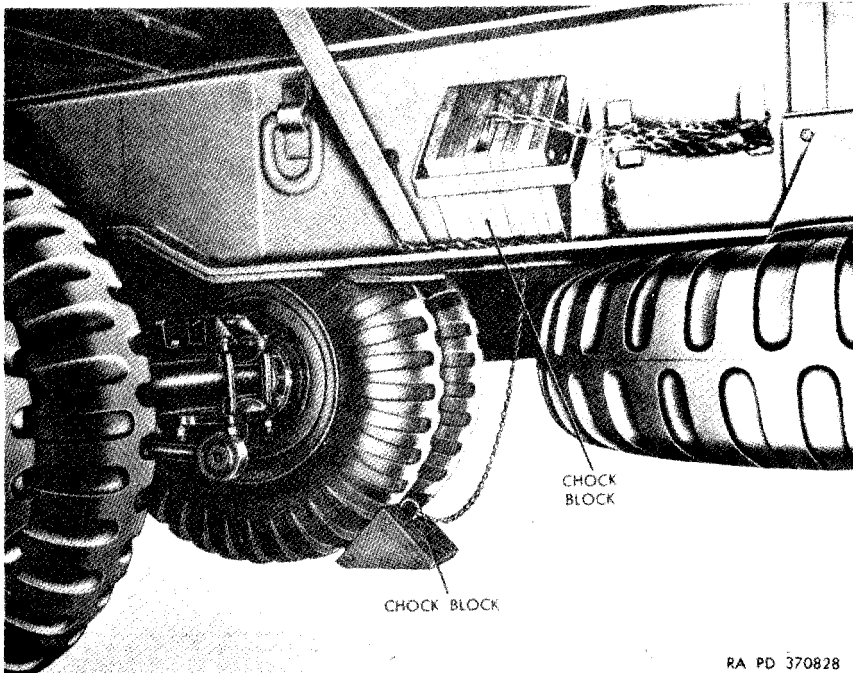

Figure 14. Chock blocks.

RA PD 370828

foot pressure applied to the brake pedal of the towing vehicle.

j. Units of the Brake Systems.

- (1) *Semitrailer M270A1.* The brake system consists of the wheel brake mechanisms, brake hydraulic master cylinders, air chambers, emergency relay valve, emergency air line, service air line, hydraulic tubes, air filters, air reservoir, and connections.
- (2) *Semitrailers M270 and M269.* The brake system consists of the wheel brake mechanisms, slack adjusters, brake air chambers, emergency relay valve, air reservoir, emergency air line, service air line, air filters, and connections.

k. Wheel Brake Mechanisms.

- (1) *Semitrailer M270A1 (fig. 15).*

(a) The wheel brake mechanisms, located within the brake drums, are of the self-centering type. This type brake assembly has two identical brake shoes and two identical wheel cylinder assemblies. The brake shoes are arranged with the toes diametrically opposite

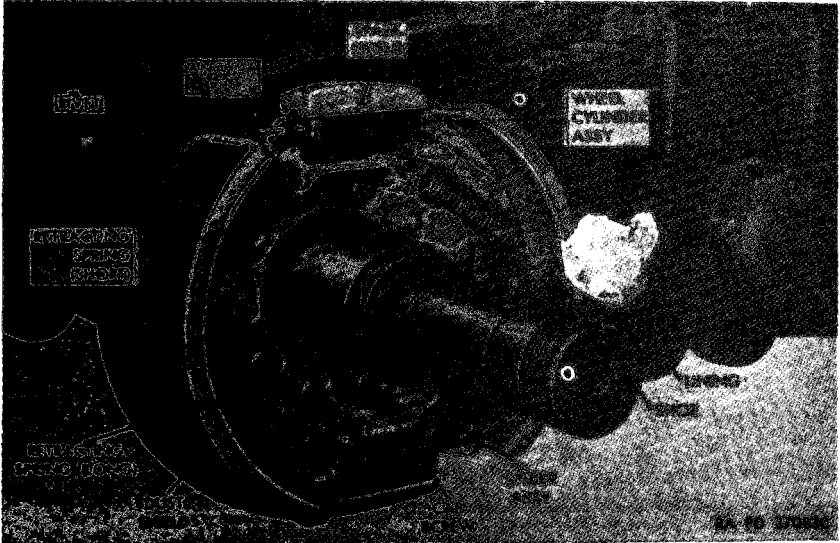

Figure 15. Wheel brake mechanism—semitrailer M270A1.

each other on the brake drum diameter and each double-end wheel cylinder assembly is placed between the toe of one brake shoe and the heel of the other brake shoe. Equal hydraulic pressure is thus applied at each end of each shoe. Shoes are always forward-acting, independently actuated in the direction of drum rotation. Shoes are anchored at either toe or heel, depending on the rotation of the drum.

- (b) When the brakes are applied, the wheel cylinder pistons apply equal force against the toe and heel of each shoe. As the shoe linings come into contact with the drum, self-energization develops. The rotation of the drum pulls the shoes against the drum surface to augment the hydraulic force acting on the shoes and produce additional braking action.
 - (c) The shoes are of the floating type, each being held in position by a shoe guide pin, plain washer, C-washer, and two brake shoe retracting springs. Each short brake shoe retracting spring is hooked to the anchor end of the brake shoe and to a projection on the shoe anchor pin; each long brake shoe retracting spring is hooked to the toe end of the brake shoe and to a spring pin centered on the spider assembly.
- (2) *Semitrailers M270 and M269 (fig. 16).*
- (a) The wheel brake mechanisms are located within the

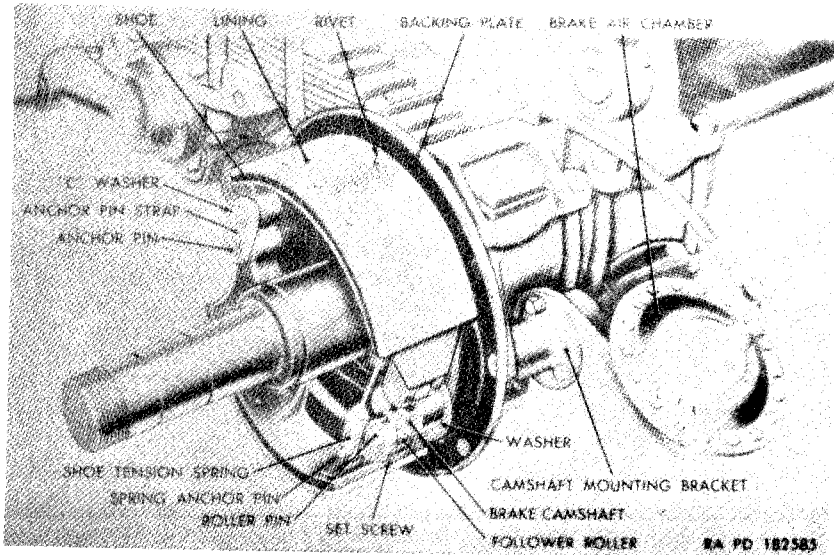

Figure 16. Wheel brake mechanism-semitrailers M270 and M269.

brake drums and are supported by the brake backing plates which are riveted to flanges on the axles. Brake camshaft mounting brackets, riveted to the backs of the brake backing plates, carry the brake camshafts on needle bearings.

- (b) Each wheel brake mechanism has two brake shoes, the outer surfaces of which are fitted with brake linings riveted to the shoes. Each shoe is anchored at one end on an (eccentric) anchor pin on which it pivots. The other end of each shoe is free to be pressed outwardly or pulled inwardly.
- (c) An S-shaped cam, on the end of the camshaft, is mounted between the free ends of the two shoes. Rotation of the cam forces the shoes outwardly to apply the brake linings to the drum.
- (d) A shoe tension spring, hooked on spring anchor pins near the free ends of the brake shoes, retracts the shoes from the drum and holds them in retracted or released position.
- (e) The free ends of the shoes are fitted with (cam) follower rollers which bear on the S-shaped cam. The contour of the cam is so designed that the positions of the brake shoes with relation to the drum are determined by the points on which the cam follower

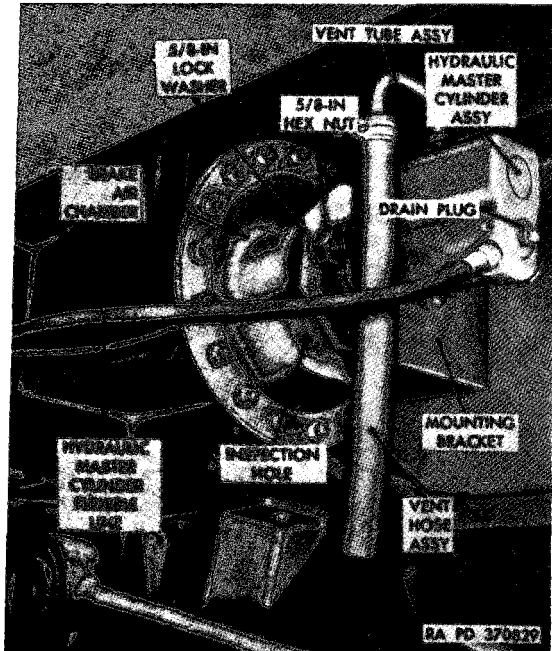

Figure 17. Brake air chamber and brake hydraulic master cylinder—installed—semitrailer M270A1.

rests on the cam. Minor adjustment of the brake (par.56c) adjusts the cam in the proper position to eliminate excessive movement when the brakes are applied.

The (eccentric) anchor pins at the pivoted ends of the brake shoes are used to relate the brake shoe arc to the contour of the brake drum. They are employed in the major brake adjustment (par.56c).

1. *Brake Hydraulic Master Cylinders and Air Chambers (Semitrailer M270A1).* The brake hydraulic master cylinders (fig. 17) are installed and secured with the brake air chambers in brackets secured to chassis frame cross members. Compressed air admitted into the air chamber acts against a diaphragm to which a push rod is attached. The air pressure moves the diaphragm and attached push rod. This movement causes a corresponding movement of a piston in the hydraulic master cylinder. Hydraulic fluid present in the body of the hydraulic master cylinder thus is put under pressure and forced into the wheel brake cylinders for a brake application. A filler cap assembly is provided at the top of the cylinder body for use when filling the cylinder with hydraulic fluid.

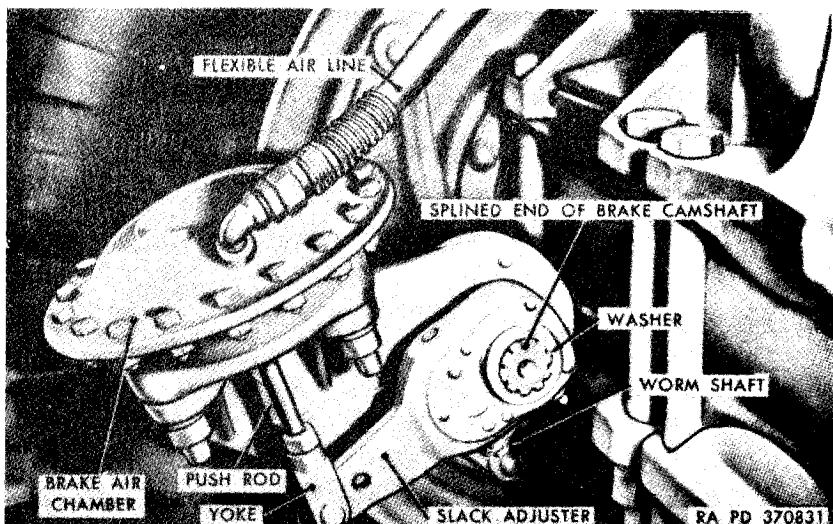

Figure 18. Brake air chamber and slack adjuster—semitrailers M270 and M269.

m. *Brake Air Chambers (Semitrailers M270 and M269).* Brake air chambers (fig. 18) are mounted on brackets adjacent to the brake mechanisms in front of the forward-rear axle and at the rear of the rear-rear axle. They convert air pressure into mechanical motion to operate the slack adjusters.

n. *slack Adjusters (Semitailers M270 and M269).* The slack adjusters (fig.18) are levers mounted on the brake camshafts. They are operated by the push rods of the brake air chambers to rotate the camshafts and cause the cams to press the brake shoes against the brake drums. Provision is made to adjust the angle of the slack adjuster on the camshaft to afford the most efficient brake operation. This is obtained when the travel of the arm of the slack adjuster is held to a minimum and full leverage is used. Such adjustment is termed the minor adjustment of the brakes (par. 56c).

11. Hubs and Brake Drums

(fig.19)

a. *General.* The brake drums and wheels are mounted on the hubs. Each hub is mounted on the spindle of its axle on two taped roller bearings. The wheels are mounted on the hub with 10 wheel studs, cap nuts, and wheel nuts. Cap nuts and wheel nuts on the right side of the vehicle have right-hand threads and are marked R. Those on the left side have left-hand threads and are marked L. Wheel nuts and cap nuts

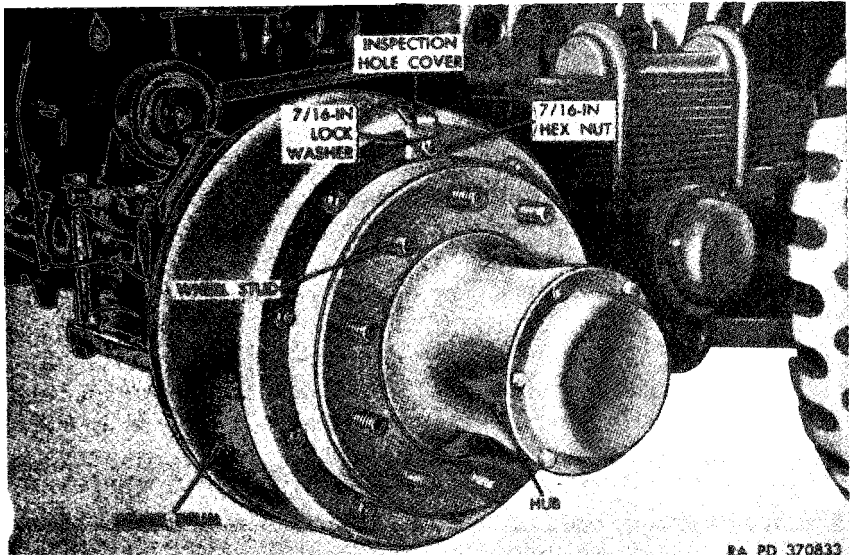

Figure 19. Hub and brake drum—semitrailer M270A1.

must be turned in the opposite direction to the normal rotation of the wheel to be loosened or removed.

Note. Because of the difference in the threads on studs and nuts, right and left hubs are not interchangeable.

The weight of the semitrailer and load is carried on two opposed tapered roller bearings in each hub. The bearing cups are a pressed fit in the hubs. The bearing cones and roller assemblies are removable for cleaning, inspection, and lubrication. The bearings are adjustable. An adjusting nut with pin, a locking washer with holes to accommodate the pin of the adjusting nut, and a jamnut secure the hub with bearings on the spindle. A grease seal and wiper are fitted on the spindle, back of the inner bearing, to protect the brake linings from lubricant.

B. Brake Drums.

- (1) *Semitrailer M270A1.* The brake drum is attached to the hub through a dished brake drum adapter. The adapter is secured to the hub by 10 wheel studs and to the drum by 10 bolts, 7/16-inch lockwashers, and to the drum by 10 bolts, 7/16-inch lockwashers, and 7/16-inch hex nuts. One of these bolts with lockwasher and The inspection hole permits the brake lining clearance to be checked. A hub cap and gasket, fastened by

six cap screws and lockwashers over the center of the hub, excludes moisture and foreign matter.

- (2) *Semitrailers M270 and M269.* The brake drum is attached to the hub through a dished brake drum adapter. The adapter is secured to the hub by 10 cap screws and lockwashers and to the drum by 10 bolts and lock nuts. These bolts, lockwashers, and nuts also secure the oil slinger to the adapter and one of them retains the inspection hole cover. The slinger is a metal plate with a hole in the center, which protects the brake lining from lubricant. The inspection hole permits the brake lining clearance to be checked. A hub cap and gasket, fastened by 10 cap screws and lockwashers, over the center of the hub, excludes moisture and foreign matter.

12. Wheels and Tires

a. *Wheels.* Two offset disk-type wheels are mounted to each hub. The inside wheel is mounted with the convex side outward, and the outer wheel with the concave side outward. The inside wheel is mounted on the wheel studs in the hub (fig. 19) and secured by capnuts. The outer wheel is mounted on the capnuts and secured by wheel nuts. Wheels have removable split lock-rings to secure the tires to the wheel rims.

b. *Tires.* Tires are military-pneumatic type cross-country tread design, size 11.00x20, 12-ply rating with controlled head. Tires are equipped with tubes and continuous flaps. Tire inflation is as follows:

Highway driving	50 psi
Cross-country driving	35 psi
Sand driving	15 psi

13. Spare Wheel and Tire Carrier Assembly

(figs. 4-6)

a. The winch-type spare wheel and tire carrier assembly is mounted on a bracket to the outer side of the right chassis frame beam, forward of the suspension.

b. A metal cable is wound on the spare wheel and tire carrier operating shaft to lift the tire to carrying position. The shaft is mounted horizontally in the main member of the tire carrier and is rotated by the wheel nut wrench. A ratchet and pawl hold the shaft against undesired rotation.

14. Landing Gear (Supports)

(fig.20)

a. The landing gear (supports) is partially retractable vertically and supports the front end or nose of the semitrailer when it is not coupled to a towing vehicle. It is located at the rear of the raised and extended portion (nose) of the chassis frame. The landing gear right and left leg assemblies are secured at the top, to brackets welded to the chassis frame. On semitrailer M270A1, U bolts attach the center portion of the landing gear assemblies to brackets welded to the longitudinal beams of the chassis frame. On semitrailers M270 and M269, welded brackets extend from the lower portion of the upper legs of the landing gear and are secured to brackets welded to the chassis frame with bolts, lockwashers, and nuts.

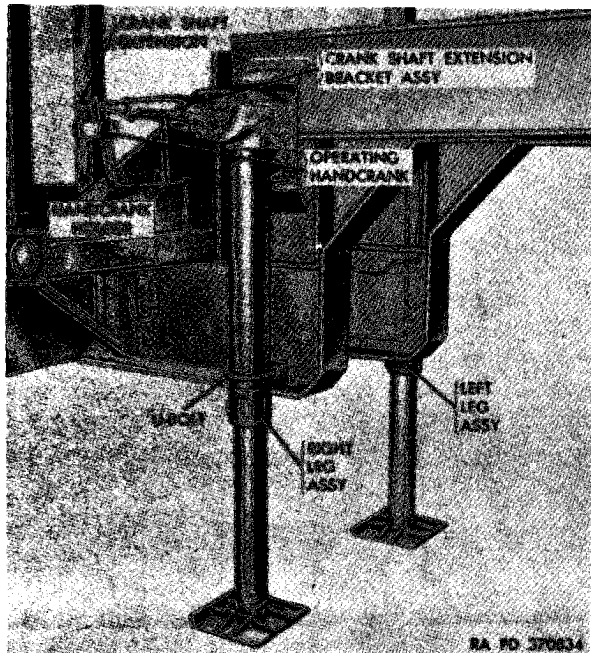

Figure 20. Landing gear—semitrailer M270A1.

b. The tubular legs of the landing gear have telescopic lower portions equipped with hinged shoes for better contact with the ground. The lower telescoping portions of the legs are raised and lowered by operating screws which rotate in fixed nuts in the lower legs.

c. A two-speed transmission (par. 28b), in a gear box at the

top of the right leg, drives the operating Screws in both legs through shafts and bevel gears. The transmission is operated by an operating handcrank. The handcrank is hinged to a crank shaft extension and is released, swung backward, and held in a holder when not in use.

15. Stowage Box, Stowage Compartment, and Tool Boxes

a. Storage Box, Semitrailer M270A1) (fig. 21).

- (1) A two-door welded steel stowage box is fastened to the right chassis frame beam and to the lower edge of the outer rail on the right side of the body frame.
- (2) Each stowage box door is hinged at the top with four hinges bolted to the frame of the box. A rubber seal is cemented to the back of each door to prevent entrance of moisture, dirt, or other foreign matter. Each door has two rotating latches. The latches are operated by folding T-type door handles, which, when folded, fit in recesses in the door.

b. Stowage Compartment (Semitrailers M270 and M269 (fig. 22).

- (1) A four-door welded steel stowage compartment is welded to the top surface of the chassis frame longitudinal beams which form the front end or nose of the semitrailer.

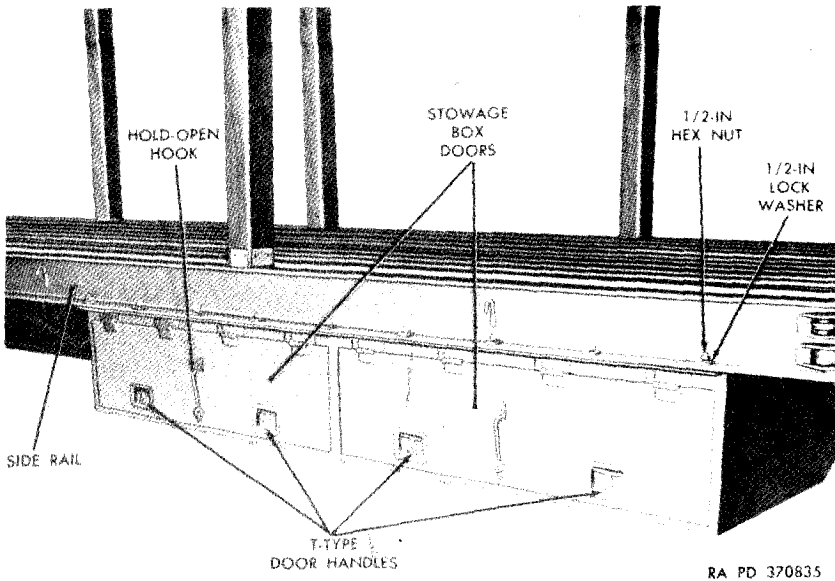

Figure 21. Stowage box—semitrailer M270A1.

- (2) Each stowage compartment door has two hinges which are bolted to the compartment upright supports. A rubber seal is cemented to the back of each door to prevent entrance of moisture, dirt, or other foreign matter. The front door and the rear intermediate door each have one rotating latch which is operated by a folding T-type door handle, which, when folded, fit in a recess in the door. These doors overlap the adjacent doors holding them in the closed position.

c. *Tool Box (fig. 23).*

- (1) Each semitrailer has a tool box located at the top of the front end or nose of the chassis frame. The tool box has as its sides, the two extended and raised beams of the chassis frame and as its bottom, a plate welded to the bottom of the beams and covering the fifth wheel upper plate and kingpin. A plate, welded between the beams, is the rear wall of the box. The mounting plate for the electrical connector and air brake couplings provide the front wall for the box.
- (2) A steel tool box door, with two hinges welded to its top surface, covers the tool box. A handle installed in two holes in the door has two washers welded to its ends that serve as stops for the handle when the

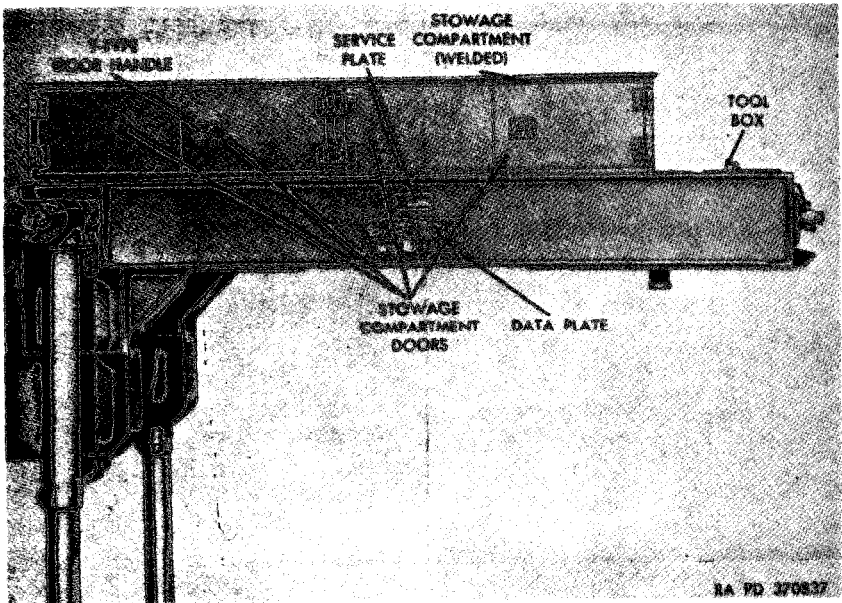

Figure 22. Stowage compartment—semitrailers M270 and M269

door is raised. A slot in the top center of the door fits over a staple welded to the front intermediate cross member of the chassis frame, permitting the door to be padlocked in the closed position.

16. Lights and Wiring (figs. 24 and 25)

a. Lights on the semitrailer are controlled by the light switch on the instrument panel of the towing vehicle. The system is protected by a circuit breaker on the towing vehicle. Lights with the same purpose, for example blackout stop lights, are on the same circuit and operate simultaneously on towing vehicle and semitrailer.

b. Electrical cables are lubbel covered with soldered terminals or connectors. The connectors are either plugs or sockets which are forced, one into the other and covered with metal shells. Clip assemblies hold the cables in place on the frames. Rubber grommets are provided where the cables pass through frame members.

c. In addition to circuit No. 90, which is the ground connection from the semitrailer receptacle to the chassis frame, there

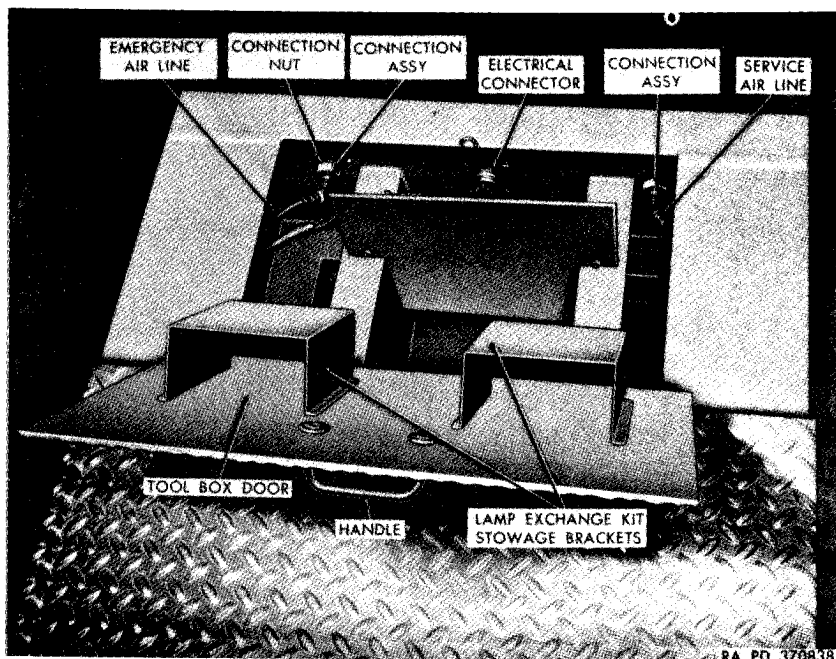
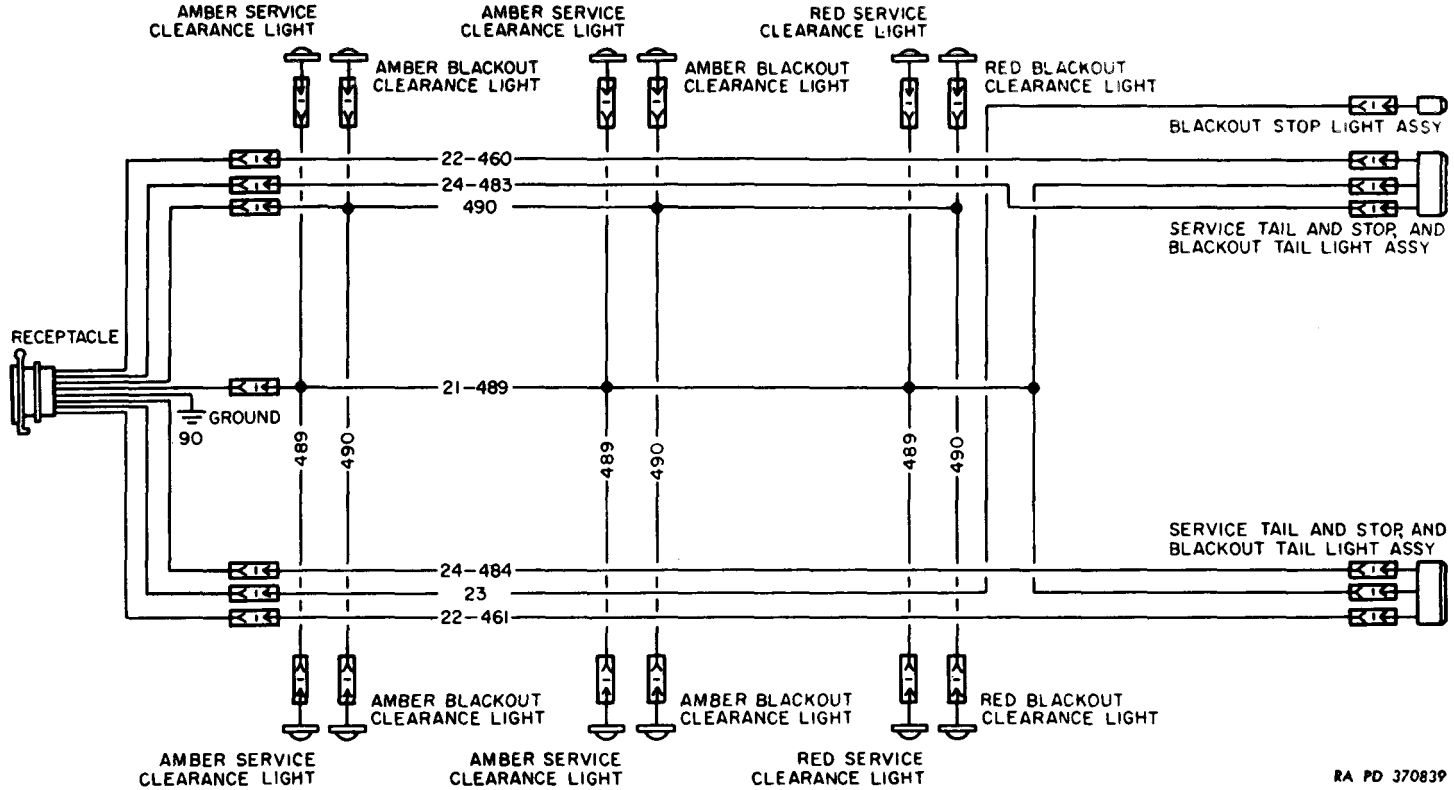

Figure 23. Tool box.



RA PD 370839

Figure 24. Wiring diagram—semitrailer M270A1.

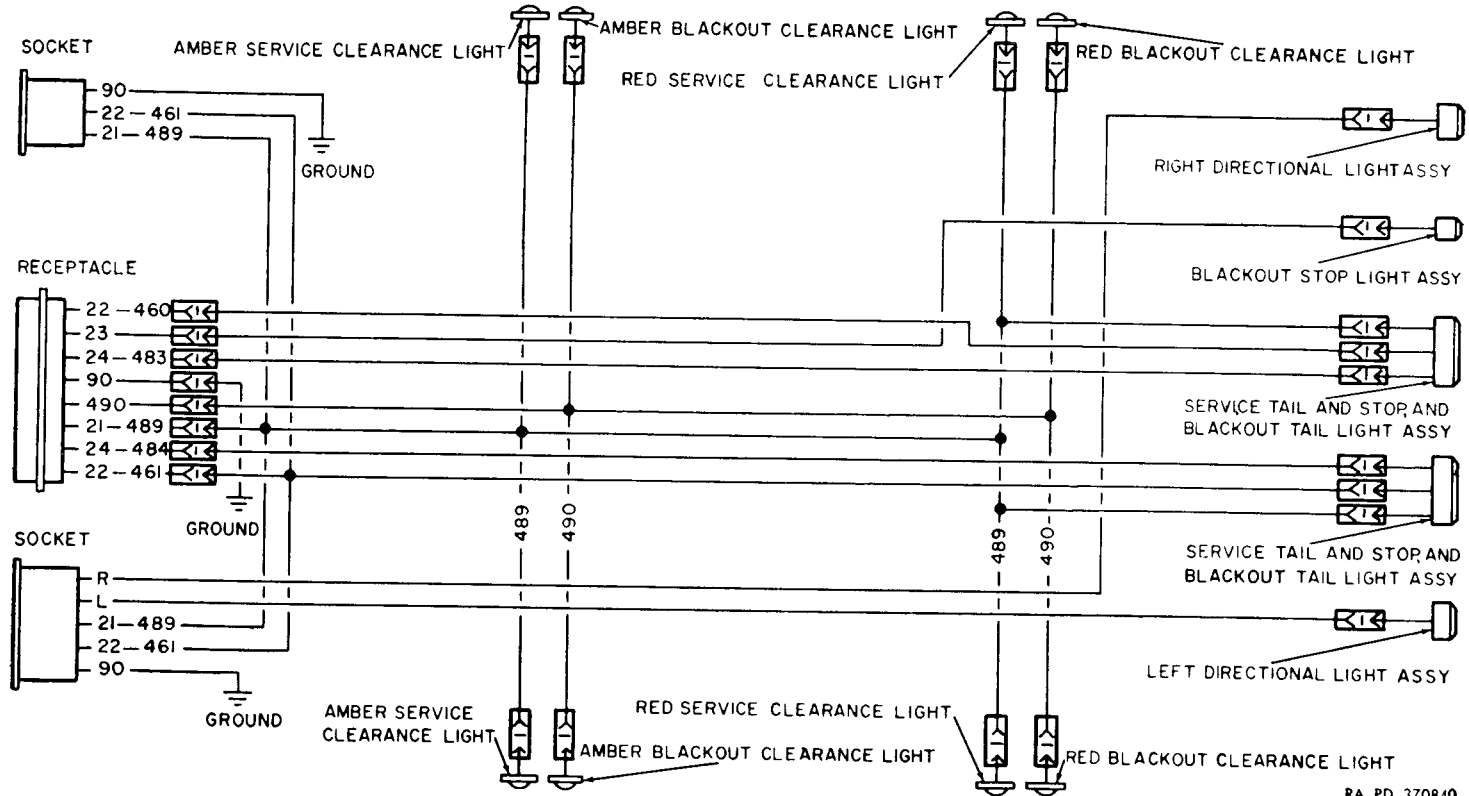

Figure 25. Wiring diagram—semitrailers M270 and M269.

RA PD 370840

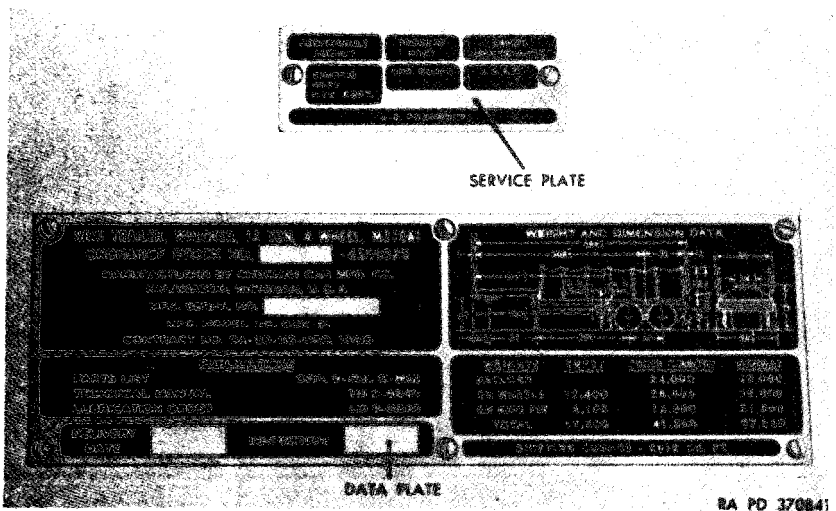

Figure 26. Data and service plates—semitrailer M270A1.

are the following circuits which are continuations of circuits on the towing vehicle:

- Circuit No. 21 to service tail-light
- Circuit No. 22 to service stop-light
- Circuit No. 23 to blackout stop-light
- Circuit No. 24 to blackout tail-light
- Circuit No. 460 turn indicator, right, service
- Circuit No. 461 turn indicator, left, service
- Circuit No. 483 turn indicator, right, blackout
- Circuit No. 484 turn indicator, left, blackout
- Circuit No. 489 service clearance light
- Circuit No. 490 blackout clearance light
- R-directional light circuit, right, service (6 and 12 volts)
- L-directional light circuit, left, service (6 and 12 volts)

17. Data and Service Plates

(figs. 26 and 27)

a. *Data Plate.* The data plate is located on the right side of the front end or nose of the chassis frame to the rear of the fifth wheel upper plate. The data plate gives the ordnance stock number, manufacturer's name and serial number, contract number, weight and dimension data, weights, shipping cubage, publications pertaining to the vehicle, delivery date, and inspectors initials.

b. *Service Plate.* The service plate is located on the chassis

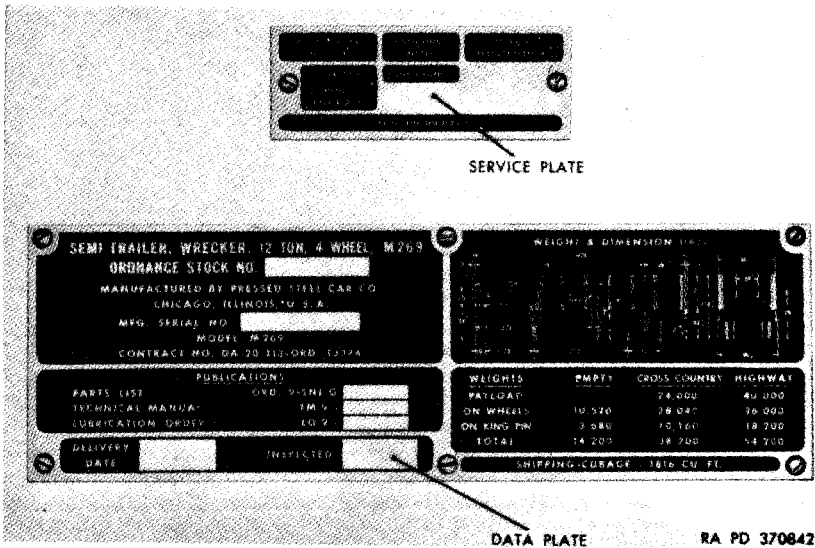

Figure 27. Data and service plates—semitrailer M269.

frame, above the data plate. It designates the responsible agency for procurement and depot maintenance.

18. Tabulated Data

a. Semitrailer.

Towing vehicle5 ton 6 x 6
 Towing facilitieskingpin
 Kingpin to landing gear:
 M270A17 ft 2 in.
 M2706 ft 8 in.
 M2696 ft 7½ in.

Dimensions overall:

Length:

M270A149 ft ½ in.
 M27048 ft ½ in.
 M26934 ft 1 in.

Width (body frame)8 ft ¾ in.

Width (front end)2 ft 10 in.

Height (to top of stakes)10 ft ¾ in.

Height (to top of front end) :

M270A15 ft 11 in.
 M2706 ft 7 5/16 in.
 M2696 ft 7 in.

Dimensions inside:

Length:

M270A149 ft 2½ in.
 M2708 ft 11½ in.
 M26933 ft 10 in.

Width 8 ft
 Height (to top of stakes) 6 ft
 weights :
 Vehicle:
 M270A1 and M270 17,500 lb
 M269 14,200 lb
 Payload:
 Hard surface roads 40,000 lb
 Cross-country 24,000 lb
 Center of gravity from ground:
 Loaded 5 ft 3¼ in.
 Empty:
 M270A1 and M270 3 ft 4 in.
 M269 3 ft 5 in.

b. Axles.

Type tubular
 Number 2
 Manufacturer:
 M270A1 Standard Forge & Axle Co
 M270 and M269 Timken Detroit Axle Co
 Diameter 5½ in.
 Spindle (diameter) 3 7/16 in.

c. Tube, with Brackets, Assembly (Trunnion Cross Tube).

Type tubular
 Make Timken design
 Diameter 3½ in.
 Spindle (diameter) 3½ in.

d. Springs.

Type semielliptic
 Manufacturer Detroit Steel Products
 Material SAE 5160
 Optional Material SAE 4155 or SAE 9260
 Hardness Brinell 388 to 444
 Length (center of bearing points when loaded 4 ft 4 in.
 to 28,000 lb gross).
 Width 4 in.
 Number of leaves 12
 Thickness of leaves 0.499 in.
 Rate (average) of deflection 6,150 lb
 Normal load 14,000 lb

e. Brakes.

Actuation:
 M270A1 air-over-hydraulic
 M270 and M269 air
 Type of brake mechanism:
 M270A1 self-centering
 M270 and M269 S-cam, two-shoe, double an-
 chor, expanding
 Make:
 M270A1 Wagner. Lockheed design
 M270 and M269 Timken design

f. Landing Gear (Supports).

Typevertical. two legs, with shoes
Manufacturer Austin Trailer Equipment Co
Operationhand crank, two speed
Width, at feet (on centers)3 ft 5 in.

g. Frame (Body Frame and Chassis Frame Combined).

Typewelded, pressed, and structural steel

Length:

M270A149 ft 8½ in.
M27048 ft 8 in.
M26933 ft 7¼ in.
Width8 ft

Main beams (depth) :

M270A1 and M27016 in.
M26914 in.

Side rails, body frame (depth)6 in.

h. Tires.

Number8
Size 11.00 x 20
TypeNDCC Military
Number of plies12

Tire inflation:

Highway driving50 psi
Cross-country driving35 psi
Sand driving15 psi

i. Wheels.

Typedual military disk
ManufacturerBudd Co
Rim size20 x 7,5
Tire retention and removalsplit lock ring
Number of studs10
Diameter of stud circle11¼ in,

Wheel bearings:

Typetapered roller
Outer cup Timken 592A
Outer cone (includes rollers) Timken 596
Inner cup Timken 592A
Inner cone (includes rollers) Timken 593A

j. Spring Seat.

Bearings:

Type tapered roller
Outer cup Timken 592A
Outer cone (includes rollers) Timken 596
Inner cone Timken 592A
Inner cup (includes rollers) Timken 593A

k. Spare Wheel and Tire Carrier.

Typeone-man cable lift
MakeNash
Operated bywheel nut wrench

CHAPTER 2
OPERATING INSTRUCTIONS

Section I. SERVICE UPON RECEIPT OF MATERIEL

19. Purpose

a. When a new or reconditioned semitrailer is first received by the using organization), it is necessary for the organizational mechanics to determine whether the semitrailer has been properly prepared for service by the supplying organization and is in condition to perform any mission to which it may be assigned when placed in service. For this purpose, inspect all assemblies, subassemblies, and accessories to be sure they are properly assembled, secure, clean, and correctly adjusted and/or lubricated. Check all tools and equipment (pars. 34-37) to be sure every item is present, in good condition, clean, and properly mounted or stowed.

b. In addition, perform a break-in of at least 500 miles on all new or reconditioned semitrailers and a sufficient number of miles on used semitrailers to completely check their operation according to procedures in paragraph 21.

c. whenever practicable, the vehicle crew will assist in the performance of these services.

20. Preliminary Services

a. *General Procedures.*

- (1) Uncrate semitrailer, if crated. Remove metal strapping, plywood, tape seals, wrapping paper, and dehydrant bags. If any exterior surfaces are coated with rust-preventive compound, remove it with mineral spirits paint thinner.
- (2) Read processing record for storage and shipment tag and follow all precautions checked thereon.
- (3) Refer to paragraph 3.

b. *Specific Procedures.* Perform the organizational mechanic or maintenance crew D (6 months or 6,000 miles) preventive-maintenance service (table III), with the following variations:

- (1) Line out the other services on the work sheet (DA Form 461 (Preventive Maintenance Service and In-

spection for Wheel and Half-Track Vehicles) and write in "New (or rebuilt) semitrailer reception."

- (2) Perform item 27 before starting road test. Lubricate all points regardless of interval.

21. Break-In Procedures

a. Refer to paragraph 31 for operating instructions. After the preliminary services have been performed, the break-in period (500 miles) may be accomplished in normal service of the semitrailer under the supervision of a competent driver. If the semitrailer was towed to the using organization, consider the mileage so traveled as break-in mileage.

b. After 500 miles of semitrailer operation, perform the organizational mechanic or maintenance crew C (1,000-mile) preventive-maintenance service (table III), with the following variation. Line out the other services on the work sheet (DA Form 461) and write in "New (or rebuilt) semitrailer 500-mile service."

c. When the semitrailer has been towed 1,000 miles, it will be placed on the regular preventive-maintenance schedule and will be given the first regular C (1,000-mile) preventive-maintenance service.

22. Correction of Deficiencies

a. Ordinary deficiencies disclosed during the preliminary inspection and servicing or during the break-in period will be corrected in the usual way; that is, by the using organization or a higher maintenance echelon.

b. Serious deficiencies, which appear to involve unsatisfactory design or material, will be reported on DA Form 468 (Unsatisfactory Equipment Report). The commander of the using organization will submit the completed form (in accordance with AR 700-38) to the Chief of Ordnance, Washington 25, D. C., ATTN :ORDFM (or to the chief of appropriate technical service for other than ordnance equipment).

Section II. CONTROLS AND OPERATION

23. General

This section describes, locates, illustrates, and furnishes the operator with sufficient information pertaining to the various controls provided for the operation of the semitrailer. It also contains instructions for the mechanical steps necessary to operate the 12-ton 4-wheel wrecker semitrailer M269, M270, or

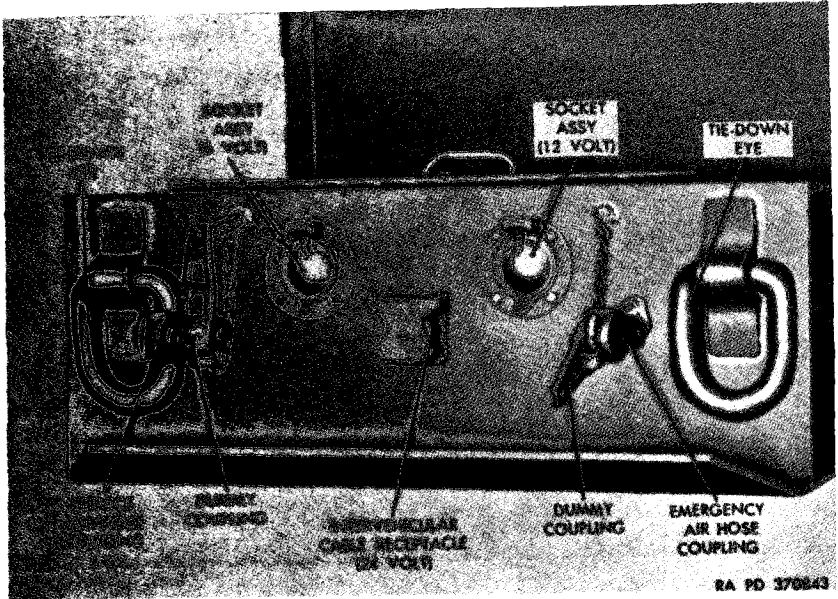

Figure 28. Controls on nose of semitrailers M270 and M269.

M270A1 under usual conditions. For operation under unusual conditions, refer to paragraphs 32 and 33.

24. Kingpin

(fig. 1)

The kingpin is a machined steel piece which protrudes from the center of the fifth wheel upper plate of the semitrailer. It is locked into the fifth wheel coupler jaws of the towing vehicle in the coupling operation (par. 31) to connect the semitrailer to the towing vehicle.

25. Brake Air Hose Couplings

(figs. 28 and 29)

A service air hose coupling and emergency air hose coupling are mounted in the front cross member of the chassis frame. When the air hose couplings on the towing vehicle are connected by intervehicular hose to these couplings, the service brakes on the semitrailer may be controlled by the brake controls on the towing vehicle.

26. Dummy Couplings

(figs. 28 and 29)

Two dummy couplings are chained to brackets welded to the front cross member of the chassis frame. They are provided to

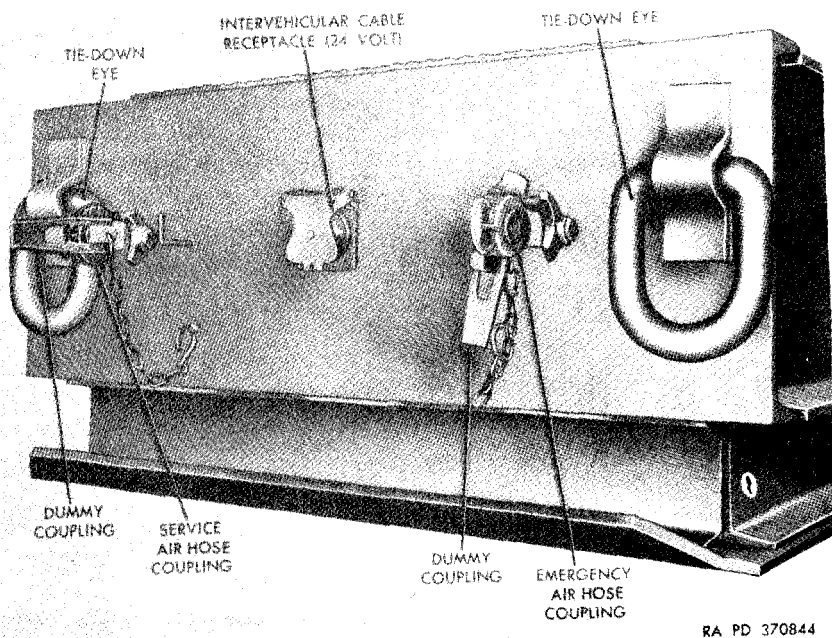

Figure 29. Controls on nose of semitrailer M270A1.

exclude dirt and moisture from the braking system and should be fitted to the service air hose coupling and emergency air hose coupling when these couplings are not connected by air hoses to those of the towing vehicle.

27. Intervehicular Cable Receptacles and Sockets

a. *Receptacle Assemblies* (figs. 28 and 29). Each semitrailer is equipped with a receptacle assembly for connection of the intervehicular cable of a towing vehicle equipped with a 24-volt electrical system. To connect the intervehicular cable, lift up the spring-loaded receptacle cover of the receptacle assembly on the semitrailer and open the plug cover on the plug of the intervehicular cable. Install the plug in the opening of the receptacle and rotate the plug slightly until the pin contacts in the plug are in alinement with their mating inserts in the receptacle, then press the plug into the receptacle. Release the spring-loaded receptacle and plug covers.

b. *Socket Assemblies* (fig. 28). Semitrailers M270 and M269 are equipped with socket assemblies for connection of the intervehicular cable of a towing vehicle equipped with either a 6-volt or 12-volt electrical system. To connect the intervehicular cable, lift up spring-loaded socket cover and press

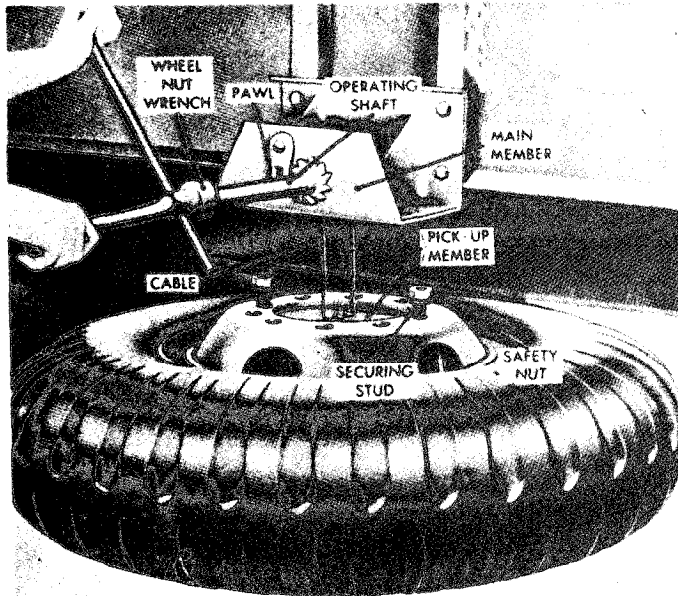

RA PD 370877

Figure 30. Operating spare wheel and tire carrier,

plug end of cable in appropriate socket assembly, Release cover.

28. Landing Gear (Supports) Operating Handcrank

(fig. 20)

a. Operating Handcrank. The operating handcrank is located on the right side of the semitrailer above the landing gear legs, It is released from its holder, engaged on its shaft, and rotated to raise the landing gear shoes from the ground, after the semitrailer has been coupled to the towing vehicle, and to lower the landing gear shoes to the ground, before the semitrailer is uncoupled from the towing vehicle. The handcrank of the semitrailers is of the ratchet type, permitting the landing gear to be raised or lowered, should full rotation of the handcrank be temporarily restricted. The handcrank should be disengaged from its shaft and affixed in its holder when not in use.

b. Two-Speed Transmission. A sliding gear arrangement in the gear housing portion of the right landing gear leg assembly permits operation of the operating handcrank at two speeds; a slow speed for raising or lowering the landing gear legs when the semitrailer is uncoupled from the towing vehicle, and a

fast speed for raising or lowering the landing gear legs when the semitrailer is coupled to the towing vehicle. To operate the handcrank at the slow speed, pull the handcrank outward to its limit of travel, and at the same time, rotate the handcrank slightly until resistance is apparent indicating that all gears are in mesh. To operate the handcrank at the fast speed, push the handcrank inward to its limit of travel and place the gears in mesh.

29. Spare Wheel and Tire Carrier Operating Shaft

(fig. 30)

The tire carrier operating shaft projects horizontally from the tire carrier main member. It is rotated with the wheel nut wrench to raise the spare tire to carrying position and to lower the spare tire to the ground for use.

30. Air Reservoir Drain Cock

(figs. 12 and 13)

The air reservoir is equipped with a drain cock for the drainage of moisture and to permit the air pressure in the semitrailer braking system to be relieved.

31. Operation Under Usual Conditions

a. Before-Operation Service. The before-operation services specified in table II should be performed before using the semitrailer.

b. Coupling Semitrailer to Towing Vehicle.

- (1) *Block wheels.* Remove chock blocks (fig. 14) from their brackets and place them firmly behind the wheels on each side of the semitrailer.
- (2) *A line towing vehicle with semitrailer.* With an assistant standing at the semitrailer to guide the driver, back the towing vehicle slowly to the nose of the semitrailer. Maneuver the towing vehicle so that the kingpin (figs. 1-3) of the semitrailer is aligned with the fifth wheel coupler jaws on the towing vehicle. Just before the fifth wheel upper plate (figs. 1-3) of the semitrailer starts to ride on the fifth wheel of the towing vehicle, stop the towing vehicle.
- (3) *Connect intervehicular hose.* Make sure that the air hose coupling on the towing vehicle tagged SERVICE is hooked up with the air hose coupling (fig. 28) bearing a similar tag on the semitrailer. This is also essential in connecting the couplings tagged EMER-

GENCY. Open the shut-off valves on the air lines of the towing vehicle. From the towing vehicle, apply the brakes on the semitrailer.

Note. This operation is performed at this time to lock the brakes on the semitrailer and prevent movement of the semitrailer which might damage the landing gear.

- (4) *Couple towing vehicle and semitrailer.* Make sure that the coupler jaws of the towing vehicle fifth wheel are open. Slowly back the towing vehicle fifth wheel under the semitrailer fifth wheel upper plate (figs. 1-3) until the coupler jaws engage the semitrailer kingpin (figs. 1-3), locking automatically. Make certain that the coupling is secure by trying to pull the towing vehicle forward with the semitrailer brakes set.

Caution: If the coupling operation is not complete and another attempt to couple must be made, pull the towing vehicle forward carefully and within the limits of the air hose. The air hose cannot be stretched.

- (5) *Connect intervehicular cable-check lights.* Plug the intervehicular cable into the receptacle or socket (figs. 28 and 29) on the nose of the semitrailer. Operate the lights from the towing vehicle to make certain that all are in working order.

Note. The lamps of the semitrailer lights must be of the same voltage as the electrical system of the towing vehicle,

- (6) *Raise landing gear (supports) (fig. 20).* Release the landing gear operating handcrank from its holder, engage the handcrank on its shaft, and rotate the handcrank to raise the shoes of the landing gear as high as they will go to provide maximum clearance. Engage the handcrank in its holder.
- (7) *Stow chock blocks.* Move the semitrailer forward to release the chock blocks. Install chock blocks and chains on their brackets.

c. *Operating Towing Vehicle and Semitrailer.*

- (1) *Driving.* In driving a towing vehicle with semitrailer, the overall length of the unit must be kept in mind when passing other vehicles and when turning. Because the combined unit is hinged at the fifth wheel, turning and backing are affected. The distribution of weight has its effect on stopping.
- (2) *Turning.* When turning corners, allow for the fact that the semitrailer wheels turn inside the turning radius of the towing vehicle. To make a right turn

at a road intersection, it is necessary for the towing vehicle to continue forward to approximately the center of the crossroad and then to cut sharply to the right to allow for the shorter turning radius of the semitrailer. The unit should be kept close enough to the road edge when such a turn is made to eliminate the possibility of a following vehicle attempting to pass on the right.

- (3) *Backing*. When backing the semitrailer with the towing vehicle, the towing vehicle is steered in the direction opposite to that desired for the semitrailer. If the semitrailer is to be backed to the right, the steering wheel of the towing vehicle is turned to the left, or counterclockwise. The front of the semitrailer will be pushed to the left and the semitrailer wheels will be steered to the right.
- (4) *Stopping*. In normal operation, the brakes of the towing vehicle and those of the semitrailer are applied simultaneously. Brake pressure should be applied gradually and smoothly.

Note. On steep grades and slippery surfaces, the hand valve on the towing vehicle must be applied first; then, the brakes of the towing vehicle are applied. This will tend to reduce the possibility of the trailer jackknifing or swinging out of the line of travel. Semitrailer brakes must not be used alone for braking.

- (5) *Parking*. When the towing-vehicle-with-semi-trailer combination is to be parked, do not set the air brakes and depend upon them to hold the vehicles. Place the chock blocks before or behind two wheels, as required, to prevent the wheels from rolling, if the unit is to be left unattended.

d. *Uncoupling Semitrailer From Towing Vehicle.*

- (1) *Block wheels*. Depending upon the terrain, place chock blocks (fig. 14) firmly behind or forward of wheels on each side of the semitrailer.
- (2) *Disconnect intervehicular hose*. Close the shut-off valves on the service and emergency air lines at the rear of the towing vehicle. Uncouple the two intervehicular hose from the service and emergency air hose couplings (fig. 28) on the nose of the semitrailer. The semitrailer brakes will set automatically when the emergency air hose is uncoupled. Fit dummy couplings on semitrailer air hose couplings.
- (3) *Disconnect intervehicular cable*. Disconnect interve-

- hicular cable from receptacle assembly or socket assembly (figs. 28 and 29) on the nose of the semitrailer.
- (4) *Lower landing gear (supports)* (fig. 20). Release the landing gear operating handcrank from its holder, engage the handcrank on its shaft, and rotate the handcrank to cause the shoes of the landing gear legs to make contact with the ground. Engage the handcrank in its holder.
 - (5) *Uncouple semitrailer from towing vehicle.* Release the semitrailer kingpin (figs. 1-3) from the towing vehicle fifth wheel coupler jaw by pulling out jaw lock handle, then driving the towing vehicle forward until the semitrailer becomes disengaged from the towing vehicle, allowing the semitrailer to rest on its landing gear.
- c. *Operating Spare Wheel and Tire Carrier* (fig. 30).
- (1) *Removing spare wheel and tire.* With wheel nut wrench, loosen two safety nuts which secure the studs of the pickup member in the main member. Rotate the tire slightly to free the studs and nuts from the slots. Fit the wheel nut wrench on the operating shaft, lift the pawl, and permit the tire to lower itself on its cable to the ground.
Caution: Maintain firm grip on wrench in lowering wheel and tire to prevent injury.
Remove the safety nuts and release the pickup member from the hub opening in the wheel.
 - (2) *Installing spare wheel and tire.* Insert the pickup member in the hub opening, fit the securing studs in two stud holes in the wheel, and screw the safety nuts loosely on the studs. With the wheel nut wrench, rotate the operating shaft to lift the wheel and pickup member until the studs and nuts can pass through the holes in the main member. Rotate the studs in the slots and anchor in place by tightening the safety nuts.

Section III. OPERATION UNDER UNUSUAL CONDITIONS

32. Operation Under Unusual Conditions

a. General Conditions.

- (1) In addition to the operating procedures described for usual conditions, special instructions of a technical nature for operating and servicing these semitrailers under unusual conditions are contained or referred to herein.

In addition to the normal preventive maintenance service, special care in cleaning and lubrication must be observed where extremes of temperature, humidity, and terrain conditions are present or anticipated. Proper cleaning, lubrication, and storage and handling of lubricants not only insure proper operation and functioning, but also guard against wear of the working parts and deterioration of the materials.

- (2) TM 21-300 contains very important instructions on driver selection, training, and supervision; and TM 21-305 prescribes special driving instructions for operating wheeled vehicles under unusual conditions.

Caution: It is imperative that the approved practices and precautions be followed. A detailed study of these technical manuals is essential for use of this materiel under unusual conditions.

- (3) Refer to paragraph 39e for lubrication under unusual conditions and to table II, for preventive maintenance checks.
- (4) When chronic failure of materiel results from subjection to extreme conditions, report of the conditions should be made on DA Form 468 (par. 3).

b. Extreme-Cold Weather Conditions.

(1) *General problems.*

(a) Extensive preparation of materiel for scheduled operation in extreme cold weather is necessary. Generally, extreme cold will cause lubricants to thicken or congeal, crack insulation and cause electrical short circuits, and will cause the various construction materials to become hard, brittle, and easily damaged or broken.

(b) For description of operations in extreme cold, refer to FM 31-70 and FM 31-71, as well as to TM 9-2855.

Caution: It is imperative that the approved practices and precautions be followed. TM 9-2855 contains information which is specifically applicable to these semitrailers as well as to other vehicles. It must be considered an essential part of this manual, not merely an explanatory supplement to it.

(2) *Lubricants (storage, handling, and use).*

(a) The operation of equipment at arctic temperatures will depend to a great extent upon the condition of lubricants. Immediate effects of careless storage and handling or improper use of these materials

are not always apparent, but any deviation from proper procedures may cause trouble at the least expected time.

(b) In arctic operations, contamination with moisture is a source of many difficulties. Moisture can be the result of snow getting into the product, condensation due to "breathing" of a partially filled container, or moisture condensed from warm air in a partially filled container when a product is brought outdoors from room temperature. Other impurities will also contaminate lubricants so their usefulness is impaired.

(c) Refer to TM 9-2855 for detailed instructions on storage, handling, and use.

c. Extreme-cold Weather Operation.

- (1) The driver of the towing vehicle must always be on the alert for indications of the effect of cold weather on the semitrailer.
- (2) The driver must be very careful when placing the semitrailer in motion after a standstill. Congealed lubricants may cause failure of parts. Tires frozen to the ground or frozen to the shape of a flat spot while underinflated must be considered. Brake shoes may be frozen fast and require preheating to avoid damage to the mating surfaces.
- (3) Wheel bearings should be thoroughly cleaned and hand-picked with the lubricant specified in the lubrication order (par. 38), as soon as the tactical situation permits.
- (4) When semitrailers are not in use, they should be placed in a sheltered spot out of the wind. If no shelter is available, place semitrailer so that its least vulnerable parts face into the wind. When semitrailers are not in use for long periods of time, if high ground is not available, prepare a footing of planks or brush. Chock in place if necessary.
- (5) After operation, clean snow, ice, and mud from semitrailers as soon as possible. Refer to table II (par. 43) for detailed after-operation procedures. Cover and shield the vehicle but keep ends of the canvas paulins off the ground to prevent them from freezing to the ground.
- (6) Check air pressure of tires (par. 52) with tire pres-

sure gage before operating semitrailer. Do not rely upon appearance of tire for inflation test.

d. Operation in Extreme-Hot Weather Conditions.

- (1) Do not place semitrailers in the sun for long periods, as the heat and sunlight will shorten the life of the tires. If possible, park semitrailer under cover to protect it from sun, sand, and dust.
- (2) Cover inactive semitrailers with paulins if no other suitable shelter is available.
- (3) Correct tire inflation pressure (par. 52).
- (4) Semitrailers that are inactive for long periods in hot, humid weather are subject to rapid rusting and accumulation of fungus growth. Make frequent inspections and clean and lubricate to prevent deterioration.
- (5) The canvas paulin should not be exposed to the direct rays of the sun, unless unavoidable.

33. Operation on Unusual Terrain and Fording

a. Sand.

- (1) For emergency operations in beach and desert sand, reduce tire inflation. For continued operations in sand, oversize balloon sand tires are necessary for all wheeled vehicles. The tread should be of plain rib and the tire of round cross section, as a tire with deeply corrugated tread (snow tread) or with a raised flat tread will break through the crust and dig into soft sand beneath, thereby stopping the vehicle and requiring it to be dug out.
- (2) Operation under extremely sandy or dusty conditions necessitates frequent inspection, cleaning, and lubrication of the semitrailer working parts.

Caution: When packing wheel bearings, it is necessary to clean the wheel bearings completely before packing with grease, since sand or dust mixed with the grease forms an abrasive mixture.

- (3) Reducing tire pressures will aid in amphibious landings and in operation in soft sand.

Note. Normal operating tire pressure is 50 psi. For operation on coral, mud, and snow, reduce tire pressure 60 percent of normal psi; for ice or soft sand, reduce tire pressure 30 percent of normal psi; and for beach sand or sand dunes, reduce the tire pressure 25 percent of normal psi. Reduced pressure gives added flotation but normal pressure must be restored as soon as normal terrain is reached, otherwise excessive wear or damage to the tire will result.

- b. Rocks and Boulders.* Tires must be as fully inflated as

the age and condition of the trailer will permit. Fully inflated tires will result in an increase in the shock transmitted to the materiel when moving over rough or rocky ground. Under-inflated tires will cause internal ruptures of the tire and damage to the tube.

c. *Mud and Snow.* Reduce tire inflation pressure for operation in soft mud or deep snow. Keep tires free from ice.

d. *Fording and Excessive Humidity.*

- (1) Wheel bearings should be cleansed and hand-packed with lubricant as specified in the lubrication order (par. 38) after each submersion.
- (2) Tire pressure should be reduced to aid in amphibious landings (TM 31-200).
- (3) Protect cables and terminals by spraying with ignition insulation compound.
- (4) Corrosive action on all parts of the semitrailer will occur in areas of high humidity and during the rainy season. Evidence will appear in the form of rust and paint blisters on metal surfaces and mildew or mold on fabrics, leather, and unpainted wooden surfaces. Protect exterior surfaces by touch-up painting and by keeping a film of engine lubricating oil (SAE-10) on unfinished exposed metal surfaces.
- (5) A careful watch must be kept for evidence of the presence of termites.

CHAPTER 3

ORGANIZATIONAL MAINTENANCE INSTRUCTIONS

Section I. PARTS, SPECIAL TOOLS, AND EQUIPMENT FOR ORGANIZATIONAL MAINTENANCE

34. General

Tools and equipment and spare parts are issued to the using organization for maintaining the material. Tools and equipment should not be used for purposes other than prescribed and, when not in use, should be properly stored in the chest and/or roll provided for them.

35. Parts

Spare parts are supplied to the using organization for replacement of those parts most likely to become worn, broken, or otherwise unserviceable, providing such operations are within the scope of organizational maintenance functions. Organizational spare parts, tools, and equipment supplied for the 12-ton 4-wheel wrecker low-bed semitrailers M270A1, M270, and M269 are listed in the ORD 7 portion of the Department of the Army Supply Manual ORD 7-8 SNL G-802, which is the authority for requisitioning replacements.

36. Common Tools and Equipment

Standard and commonly used tools and equipment having general application to this material are authorized for issue to 1st echelon by the ORD 7 portion of ORD 7-8 SNL G-802. Common tools and equipment for 2d echelon are listed in ORD 6 SNL J-7, Sections 1, 2, and 3; and ORD 6 SNL J-10, Section 4; and are authorized for issue by tables of allowances and tables of organizational equipment.

37. Special Tools and Equipment

Certain tools and equipment specially designed for organizational maintenance, repair, and general use with the materiel are listed in table I for information only. This listing is not to be used for requisitioning replacements.

Note. All tools and equipment for the maintenance, adjustment, or repair of the semitrailer are carried on the towing vehicle.

Table I. Special tools and equipment for organizational maintenance.

Item	Identifying No.	References		Use
		Fig.	Par.	
REMOVER AND REPLACER, bearing cup, 2 leg, $\frac{3}{4}$ in. x $1\frac{1}{2}$ x 8 in.	41-R-2374-805 (7950159)	31, 39	53h, 53i	Removing and installing wheel bearing and spring seat bearing cups.
WRENCH, dble-end, tube, octagon, 4 $\frac{7}{16}$ and 4 $\frac{15}{16}$ in. opngs, 4 in. lg.	41-W-3825-72	31, 38	53a, 53c, 55a, 55e	Removing, installing, and adjusting wheel and spring seat bearing nuts.

Section II. LUBRICATION AND PAINTING

38. Lubrication Order

(fig.32)

a. The lubrication order prescribes cleaning and lubricating procedures as to locations, intervals, and proper materials for these semitrailers.

b. A lubrication order is issued with each semitrailer and is to be carried with it at all times. In the event the semitrailer is received without a copy, the using organization will immediately requisition one. See DA Pam 310-4 for lubrication order of current date. Lubrication which is to be performed by ordnance maintenance personnel is listed on the lubrication order in the NOTES.

39. General Lubrication Instructions Under Usual Conditions

a. Usual Conditions. Service intervals specified on the lubrication order are for normal operation and where moderate temperature, humidity, and atmospheric conditions prevail.

b. Lubrication Equipment. No lubrication equipment is carried on the semitrailer. Lubrication equipment supplied with the towing vehicle is to be used in lubricating the semitrailer. Clean this equipment both before and after use. Operate the lubricating guns carefully and in such a manner as to insure a proper distribution of the lubricant.

c. Points of Application.

(1) Lubricating fittings, oil holes, and wheel bearings are shown in figures 33 and 34 and are referenced to the lubrication order. Wipe the lubricating fittings and

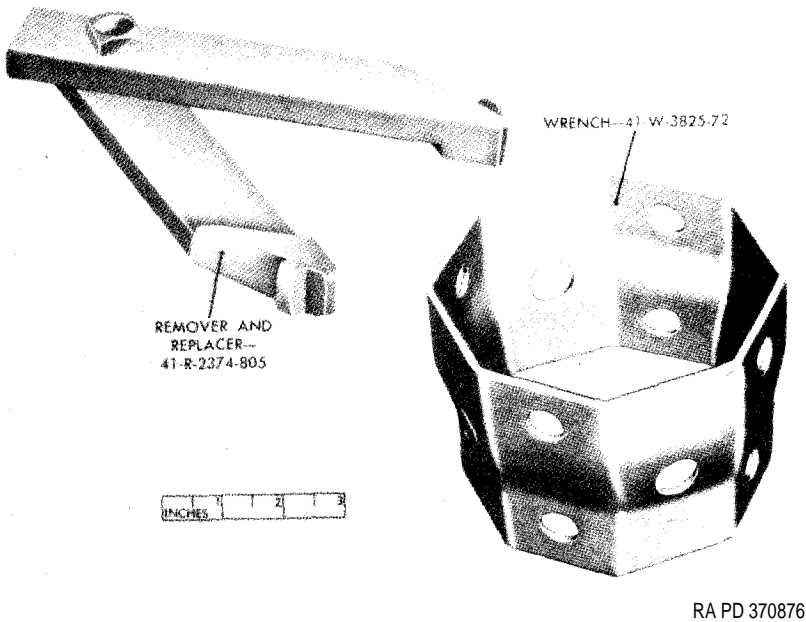

Figure 31. Special tools for organizational maintenance.

surrounding surfaces clean before and after lubricant is applied.

- (2) A $\frac{3}{4}$ -inch red circle should be painted around each lubricating fitting and oil hole.
- (3) Clean and lubricate unsealed bearings as follows:

- (a) Wash all of the lubricant out of the bearings and from the inside of hubs with mineral spirits paint thinner, and dry the parts thoroughly.

Caution: Bearings must not be dried or spun with compressed air. See TM 37-265 for care and maintenance of bearings.

- (b) Pack the bearings by hand or with a mechanical packer, introducing the lubricant carefully between the rollers. Do not smear grease only on the outside of the bearings and expect it to work in. Great care must be exercised to insure that dirt, grit, lint, or other contaminants are not introduced into the bearings. If the bearings are not to be installed immediately after repacking, they should be wrapped in clean oilproof paper to protect them from contaminants.

- (c) After the bearings are properly lubricated, pack the hub with sufficient amount of lubricant to uniformly fill it to the inside diameters of the inner and outer races. Coat the spindles and hub caps with a thin layer of lubricant (not over 1/16-inch) to prevent rusting. Do not fill the hub caps to serve as grease cups under any circumstances. They should be lightly coated, however, to prevent rusting.

Note. For normal operation, lubricate wheel bearings at 12,000 miles or at annual intervals, whichever occurs first.

d. Reports and Records

- (1) Report unsatisfactory performance of materiel or defects in the application or effect of prescribed petroleum fuels, lubricants, and preserving materials, using DA Form 468 (Unsatisfactory Equipment Report).
- (2) Maintain a record of lubrication of the vehicle on DA Form 460 (Preventive Maintenance Roster).

c. Lubrication Under Unusual Conditions.

(1) General.

- (a) *Service intervals.* Reduce service intervals specified on the lubrication order, i.e., lubricate more frequently, to compensate for abnormal or extreme conditions, such as high or low temperature, prolonged periods of high speed operation, continued operation in sand or dust, immersion in water, or exposure to moisture. Any one of these operations or conditions may cause contamination and quickly destroy the protective properties of the lubricant. Intervals may be extended during inactive periods commensurate with adequate preservation.
- (b) *Changing grade of lubricants.* Lubricants are prescribed in the "Key" (fig. 32) in accordance with three temperature ranges: above 320 F., 40° to -10° F., and 0° to -65° F. Change the grade of lubricants whenever weather forecast data indicate that air temperatures will be consistently in the next higher or lower temperature range, or when sluggish operation caused by thickening lubricant occurs. Normally, no change in grade will be made when a temporary change in temperature is encountered. However, if the operation of the materiel is encumbered by a drop in temperature, a change in grade of lubricant will be made to restore normal opera-

LUBRICATION ORDER

LO 9-8240

29 November 1955

LC 36A9-9-1-1

SEMITRAILER, WRECKER, LOW BED, 12 TON, 4 WHEEL,

References. TM 9-8240, ORD 7 SNL G-802 **M269, M270, M270A1**

Intervals are based on normal operation. Reduce to compensate for abnormal operation and severe conditions or contaminated lubricants. During inactive periods, intervals may be extended commensurate with adequate preservation. Relubricate after washing or farding.

Clean fittings before lubricating. Clean parts with THINNER, paint, volatile mineral spirits (TPM) or SOLVENT dry cleaning (SD). Dry before lubricating. Lubricate dotted arrow points on both sides of the equipment.

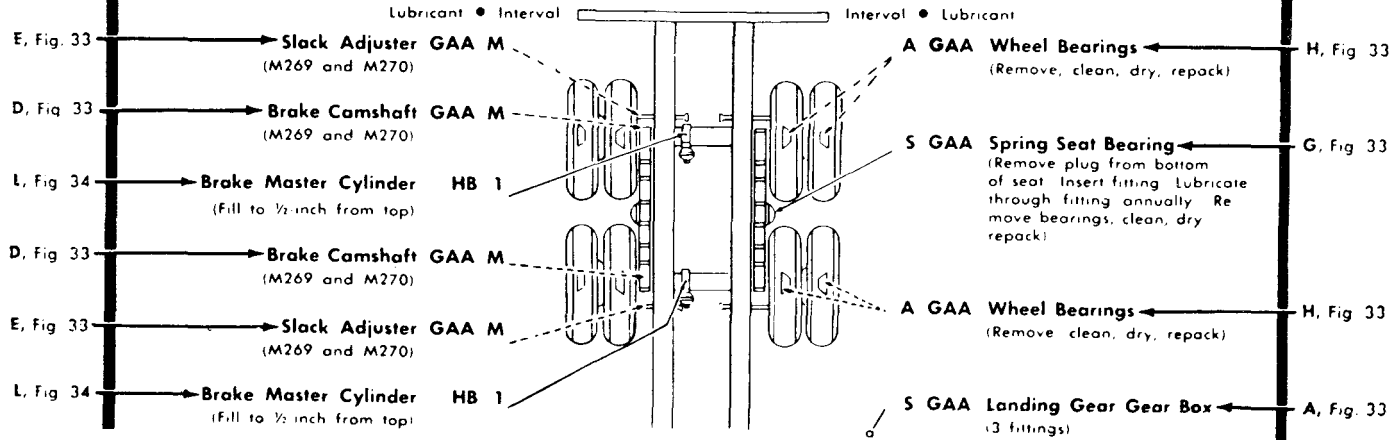
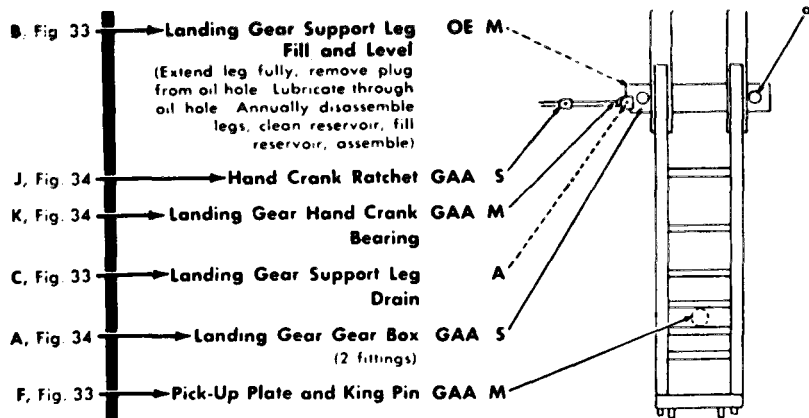

Figure 32. Lubrication order.



- NOTES -

- 1 **OIL CAN POINTS** - Monthly lubricate hinges and latches, landing gear foot and crank assemblies, spare wheel and tire carrier with PL
- 2 **DO NOT LUBRICATE** - Springs

Copy of this lubrication order will remain with the equipment at all times, instructions contained herein are mandatory and supersede all conflicting lubricating instructions dated prior to the date of this lubrication order

BY ORDER OF THE SECRETARY OF THE ARMY

MAXWELL D TAYLOR
General, United States Army
Chief of Staff

OFFICIAL:
JOHN A. KLEIN
Major General, United States Army,
The Adjutant General

- KEY -

LUBRICANTS	EXPECTED TEMPERATURES			FOR ARCTIC OPERATION refer to TM 9-2855	LUBRICANTS	INTERVALS
	above +32°F	+40°F to -10°F	0°F to -65°F			
OE-OIL, lubr. engine	OE 30	OE 10	OES		OES-OIL, lubr. engine sub zero	M - Monthly
PL-OIL, lubr. preservative	PL (Med)	PL (Special)	PL (Special)			S - Semiannually
GAA-GREASE, lubr. automotive and artillery	GAA	GAA	GAA			1-1,000 miles
HB-FLUID, hydraulic brake	HB	HB	HBA			A - Annually

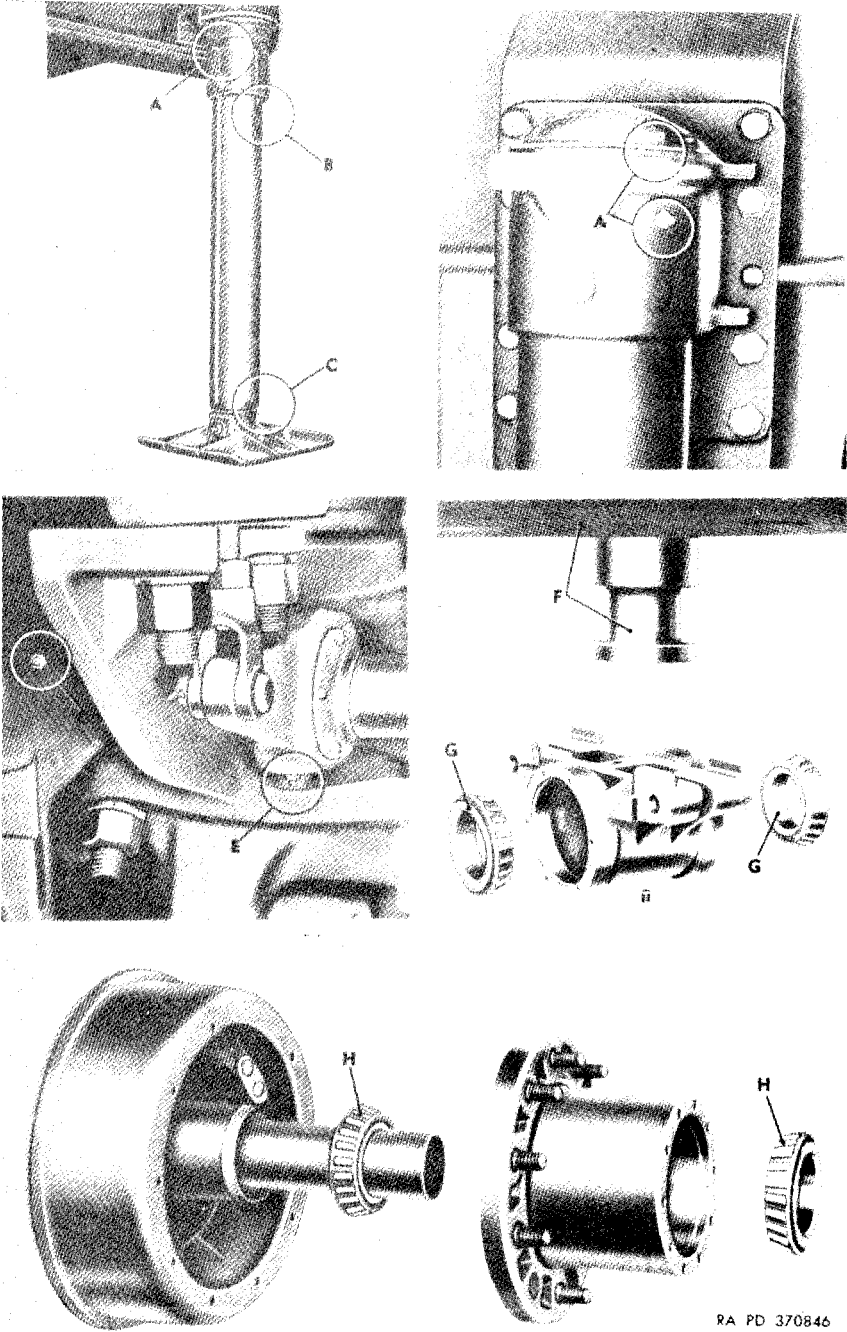

RA PD 370846

Figure 33. Localized lubrication points (A-H)

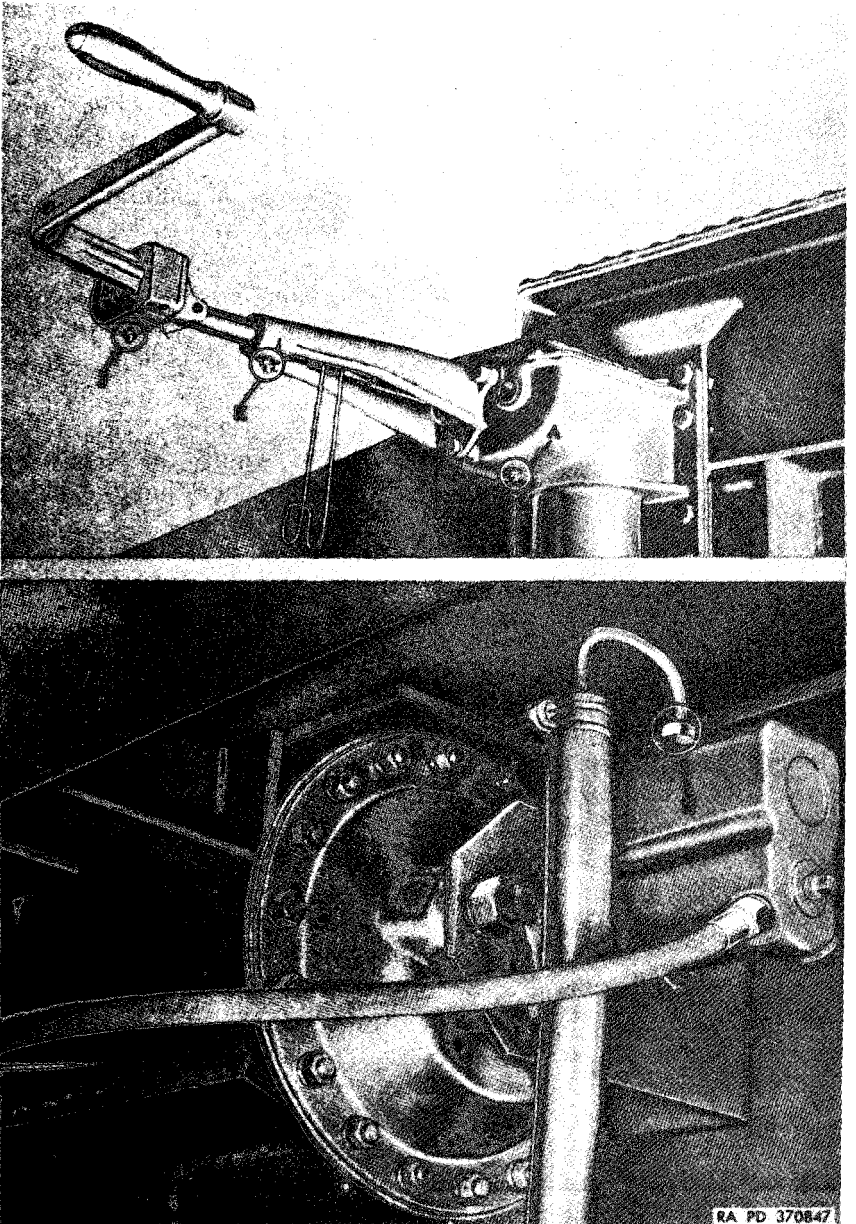

Figure 34. Localized lubrication points (J-L).

tion even if the drop in temperature is expected to be only temporary.

- (2) *Extreme-Cold Weather.* Refer to TM 9-2855 for instructions on necessary special preliminary lubrication.

- (3) *Extreme-Hot Weather.* Special lubricants will not ordinarily be required at extremely high temperatures, as lubricants prescribed for temperatures above 32° F. provide adequate protection. However, more frequent servicing is necessary because the heat tends to dissipate the lubricants.
- (4) *Humid and salt air conditions.* High humidity, moisture, or salt air tend to contaminate the lubricant, necessitating more frequent service.
- (5) *After fording.* After any fording operation, perform the maintenance described in paragraph 33d which covers maintenance operations after fording and includes special lubricating instructions.
- (6) *Dusty or sandy conditions.* If prolonged travel has occurred under dusty or sandy conditions, clean and inspect all points of lubrication for contaminated lubricants. Lubricate as necessary.

Note. A lubricant which is contaminated by dust or sand makes an abrasive mixture that causes rapid wear of parts.

40. Painting

Instructions for the preparation of the materiel for painting, methods of painting, and materials to be used are contained in TM 9-2851. Instructions for camouflage painting are contained in FM 5-20B.

Section III. PREVENTIVE-MAINTENANCE SERVICE

41. General

a. Responsibilities and Intervals. Preventive-maintenance services are the responsibility of the using organization. These services consist generally of daily operator's services (daily A services) performed by the operator or crew, and of biweekly services (biweekly B services) performed by the crew (under supervision of the squad, section, and platoon leaders); and of the scheduled services to be performed by organizational maintenance personnel (C and D services). Intervals are based on normal operations. Reduce intervals for abnormal operations or severe conditions. Intervals during inactive periods may be extended accordingly.

b. Definition of Terms. Inspection to see if items are in good condition, correctly assembled or stowed, secure, not excessively worn, not leaking, and adequately lubricated applies to most items in the preventive-maintenance procedures. Any or all of these checks that are pertinent to any item (including

supporting, attaching, or connecting members (will be performed automatically, as general procedures, in addition to any specific procedures given.

- (1) Inspection for "good condition" is usually visual inspection to determine if the unit is safe or serviceable. "Good condition" is explained further as meaning: not bent or twisted, not chafed or burned, not broken or cracked, not bare or frayed, not dented or collapsed, not torn or cut, or not deteriorated.
- (2) Inspection of a unit to determine if it is "correctly assembled or stowed" is usually a visual inspection to see if the unit is in normal position in the semitrailer and if all its parts are present and in their correct relative positions.
- (3) Inspection of a unit to see if it is "secure" is usually a visual, hand-feel, pry-bar, wrench, or screwdriver inspection for looseness in the unit. This inspection will include any brackets, lockwashers, locknuts, locking wires, and cotter pins as well as any connecting tubes, hoses, or wires.
- (4) "Excessively worn" is understood to mean worn beyond serviceable limits, or likely to fail if not replaced before the next scheduled inspection. Excessive wear of mating parts or linkage connections is usually evidenced by too much play (lash or lost motion). It includes illegibility as applied to markings, data and caution plates, and printed matter.
- (5) Where the instruction "tighten" appears in the procedures, it means tighten with a wrench, even if the item appears to be secure.
- (6) Such expressions as "adjust if necessary" or "replace if necessary" are not used in the specific procedures. It is understood that whenever inspection reveals the need of adjustments, repairs, or replacement, the necessary action will be taken.

42. Cleaning

a. General. Any special cleaning instructions required for specific mechanisms or parts are contained in the pertinent section. General cleaning instructions are as follows:

- (1) Use mineral spirits paint thinner or dry-cleaning solvent to clean or wash grease or oil from all parts of the semitrailer.
- (2) A solution of one part grease-cleaning compound to

four parts of mineral spirits paint thinner may be used for dissolving grease and oil from chassis frame and other parts. After cleaning, use cold water to rinse off and solution which remains.

- (3) After the parts have been cleaned, rinse and dry them thoroughly. Apply a light grade of oil to all polished metal surfaces to prevent rusting.
- (4) Before installing new parts, remove any preservative materials, such as rust-preventive compound, protective grease, etc.; prepare parts as required (oil seals, etc.) ; and for those parts requiring lubrication, apply the lubricant prescribed in the lubrication order (fig. 32).

b). General Precautions in Cleaning.

- (1) Mineral spirits paint thinner or dry-cleaning solvent is flammable and should not be used near an open flame. Fire extinguishers should be provided when these materials are used. In addition, it evaporates quickly and has a drying effect on the skin. If used without gloves, it may cause cracks in the skin and, in the case of some individuals, a mild irritation or inflammation. Use only in well ventilated places.
- (2) Avoid getting products such as mineral spirits paint thinner, engine fuels, or lubricants on rubber parts as they will deteriorate the rubber.
- (3) The use of diesel fuel oil, gasoline, or benzene (benzol) for cleaning is prohibited.

c. Nameplates. Nameplates, caution plates, and instruction plates made of steel rust very rapidly. When they are found to be in a rusty condition, they should be thoroughly cleaned and heavily coated with an application of lacquer.

43. Preventive Maintenance by Driver or Operator

a. Purpose. To insure mechanical efficiency, it is necessary that the semitrailer be systematically inspected at intervals each day it is operated, and also weekly, so that defects may be discovered and corrected before they result in serious damage or failure. Certain scheduled maintenance services will be performed at these designated intervals. Any defects or unsatisfactory operating characteristics beyond the scope of the driver or operator to correct must be reported at the earliest opportunity to the designated individual in authority.

b. Services. Driver's or operator's preventive maintenance services are listed in table II. Every organization must thor-

oughly school its personnel in performing the maintenance procedures for this semitrailer as set forth in this manual.

Table II. Driver's or Operator's Preventive Maintenance Services

Intervals					Procedure
Daily A				Biweekly B	
Before-Operation	During-Operation	At-the-halt	After-Operation		
					USUAL CONDITIONS
X	X	Caution: Place all tags describing condition of semitrailer in a conspicuous location so they will not be overlooked.
		X	X	X	Tires. Gage tires for correct pressure (par 52). If hot, do not reduce pressure.
				X	Remove penetrating objects such as nails or glass. Remove stones from between duals. Note any apparent loss of air, unusual wear, or missing valve caps.
X			X	Wheels. Inspect wheel nuts and cap screws to see that they are present and secure.
X	Brake lose, light cable. Make certain that intervehicular cable and brake hose between towing vehicle and trailer are securely connected and in good condition.
X	Vehicle equipment. Visually inspect vehicle publications, including Standard Form 91 (Operator's Report of Motor-Vehicle Accident) and DA Form 461,
X		X	X	Operate lights (if tactical situation permits) and observe functioning. Visually inspect reflectors.
X	X	X	X	Leaks, general (semitrailer M270 A1). Look under semitrailer for any indication of brake fluid leaks.
X	X	X	X	Visually inspect body, spare tire carrier, and stowage box. See that nothing will drag on the ground.

Table II. Driver's or Operator's Preventive Maintenance Services—Continued.

Intervals					Procedure
Before- Operation	Daily A			Biweekly B	
	During- Operation	At the- halt	After- Operation		
X		X	X	X	USUAL CONDITIONS— Continued. Check for any tampering or damage that may have occurred since last inspection.
	X				<i>General operations.</i> Be alert for any unusual noises or abnormal condition that might indicate a shifting of the load or defective performance.
	X				<i>Brakes.</i> Any time the brakes are used, consider it a test and note any unusual or unsatisfactory performance.
				X	Adjust brakes, if necessary (par. 56).
		X	X	X	<i>Operating faults.</i> Investigate and correct or report any faults noted during operation.
		X			Be sure all locking devices are secure. Check load for looseness or shifting.
		X	X	X	<i>Springs.</i> Check springs for abnormal sag, broken or shifted leaves, loose or missing rebound clips, pins, or U-bolts.
			X		<i>Air line filters.</i> Remove drain plugs (fig. 45); drain air filters and replace plugs.
				X	Clean air filter (par. 59).
			X	X	<i>Air reservoir.</i> Drain condensation (par. 10g). Check to see that reservoir and air line connections are secure.
			X	X	<i>Lubricate.</i> Lubricate in accordance with instructions contained in lubrication order (fig. 32).
			X		<i>Clean.</i> Clean dirt and foreign matter from interior of body. When practicable, wipe off exterior of equipment.
				X	Wash semitrailer, if possible; otherwise, wipe off thoroughly.

Table II. Driver's or Operator's Preventive Maintenance Services—Continued.

Intervals					Procedure
Before- Operation	Daily A			Biweekly B	
	During- Operation	At-the- halt	After- Operation		
					USUAL CONDITIONS— Continued.
				X	<i>Assemblies.</i> Inspect assemblies such as air reservoir, spare tire carrier, tool box, rear step, wheel chock blocks, and landing gear for looseness of mountings or connections
				X	<i>Electrical wiring</i> Check all accessible wiring and make sure that it is securely connected and supported, that insulation is not cracked or chafed. Report serious defects.

44. Preventive Maintenance by Organizational Maintenance Mechanics

a. *Intervals.* The indicated frequency of the prescribed preventive-maintenance services is considered a minimum requirement for normal operation of semitrailer. Under unusual operating conditions, such as extreme temperatures, dust or sand, or extremely wet terrain, it may be necessary to perform certain maintenance services more frequently.

Note. A semitrailer used habitually with the same towing vehicle will be given preventive-maintenance services with the towing vehicle. A semitrailer not used habitually with the same towing vehicle will be given preventive maintenance services as a separate vehicle.

b. *Driver or operator Participation.* The drivers or operators should accompany their vehicles and assist the organizational mechanics while periodic organizational preventive-maintenance services are performed. Ordinarily, the driver should present the semitrailer for a scheduled preventive-maintenance service in a reasonably clean condition.

c. *Special services.* These are indicated by numbers in the columns of DA Form 461 (e below) which show the interval at which the services are to be performed, and show that the parts or assemblies are to receive certain mandatory services. For example, an item number in one or both columns opposite a *tighten* procedure means that the actual tightening of the

object must be performed. The special services are as follows:

- (1) *Adjust.* Make all necessary adjustments in accordance with the pertinent section of this manual, technical bulletins, or other current directives.
- (2) *Clean.* Clean the unit as outlined in paragraph 42 to remove old lubricant, dirt, and other foreign material.
- (3) *Special lubrication.* This applies either to lubrication operations that do not appear on the semitrailer lubrication order or to items that do appear but which should be performed in connection with the maintenance operations, if parts have to be disassembled for inspection or service.
- (4) *Serve.* This usually consists of performing special operations, such as draining and refilling units with oil, and changing or cleaning the air filter.
- (5) *Tighten.* All tightening operations should be performed with sufficient wrench torque (force on the wrench handle) to tighten the unit according to good mechanical practice. Use a torque-indicating wrench where specified. Do not overtighten, as this may strip threads or cause distortion. Tightening will always be understood to include the correct installation of lockwasher, locknuts, locking wire, or cotter pins provided to secure the tightened nut.

d. Special Conditions. When conditions make it difficult to perform the complete preventive-maintenance procedures at one time, they can sometimes be handled in sections, planning to complete all operations within the week if possible. All available time at halts and in bivouac areas must be utilized, if necessary, to insure that maintenance operations are completed. When limited by the tactical situation, items with special services in the columns should be given first consideration.

e. DA Form 461. The numbers of the preventive-maintenance procedures that follow are identical with those outlined in DA Form 461. Certain items on the form that do not apply to this vehicle are not included in the procedures in this manual. In general, the sequence of items on the form will be followed, but in some instances there is deviation for conservation of the mechanic's time and effort.

f. Procedures. Table III lists the services to be performed by the organizational mechanic or maintenance crew at the designated intervals. Each page of the table has two columns at its left edge corresponding to the scheduled C and D serv-

ices. Very often it will be found that a particular procedure does not apply to both scheduled maintenances. In order to determine which procedure to follow, look down the column corresponding to the maintenance procedure, and wherever an item appears, perform the operations indicated opposite the number.

Table III. Organizational Mechanics or Maintenance Crews C and D Preventive-Maintenance Services.

Intervals		Procedure
D (6 months or 6,000 miles whichever occurs first)	C (1,000 miles)	
		<p style="text-align: center;">INSPECTION AND ROAD TEST</p> <p>Note. When the tactical situation does not permit a full road test, perform only those items that require little or no movement of the semitrailer. When a road test can be made, it should be approximately 3 miles but not over 5 miles.</p> <p>Before operation: <i>Tires, general visual inspection of semitrailer and equipment. Perform the before-operation service (par.43).</i></p>
6	6	<p><i>Air pressure.</i> With breaking systems of towing vehicle and semi trailer properly connected, inspect for leaks in the semitrailer air brake system by stopping the engine when the air pressure is at a maximum and noticing if there is any appreciable drop on the air pressure gage within 1 minute.</p>
7	7	<p><i>Brakes braking effect, feel, side pull, noise, chatter, pedal travel, and hand control.</i> Apply semitrailer brakes alone and observe if they operate effectively. Disconnect hose from towing vehicle and see if semitrailer brakes apply.</p>
10	10	<p><i>Unusual noises-attachments, body, and wheels.</i> At all times during the road test, be alert for unusual or excessive noises that may indicate looseness, defects, or deficient lubrication in these components.</p>
11	11	<p><i>Lamps-tail, clearance, stop, and blackout.</i> During stops in the road test, test the operation of these exterior lights. Note condition of lights and safety reflectors.</p>
25	25	<p style="text-align: center;">AFTER ROAD TEST</p> <p><i>Temperatures-brake drums, hubs.</i> Immediately after the road test, feel these units cautiously. An overheated wheel hub and brake drum indicates an improperly adjusted, defective, or dry wheel bearing, or a dragging brake. An abnormally cool condition indicates an inoperative brake.</p>

Table III. Organizational Mechanics or Maintenance Crews C and D Preventive-Maintenance Services-Continued.

Intervals		Procedure
D (6 months or 6,000 miles whichever occurs first)	C (1,000 miles)	
		AFTER ROAD TEST-Continued.
26		<i>Leaks.</i> Check for hydraulic oil leaks at hydraulic master cylinder and wheel cylinders.
27	27	<i>Lubrication-lubricate semitrailer in accordance with lubrication order</i> (fig. 32). Coordinate with inspection and disassembly operations to avoid duplication.
27	27	During lubrication, inspect tires for unusual wear, penetrating objects, and proper matching.
27		Rotate and match tires according to tread design and degree of wear. Tighten wheel nuts.
		MAINTENANCE OPERATION
39		<i>Brake shoes-linings, links, guides, anchors, supports, cams, hose, and chambers.</i> Inspect brake lines and air chambers and test linkage for freedom of action. Open drain cock and drain water from air reservoir (par. 61a) and air filter (fig. 45).
39		Wheel bearings will be disassembled, cleaned, and repacked in every <i>second</i> 6,000-mile inspection or <i>annually</i> . If the wheel bearings are due for repacking, remove wheels and hubs (par. 53) and examine brake drums, shoes, linings, links, guides, anchors, supports, return springs, and cams. Clean the spider. If the wheel bearings are not due for repacking, inspect the lining through the lining inspection hole in the brake drum (fig. 19). Adjust brakes (par. 56). If wheels have not been disassembled from hubs, tighten wheel bearing adjusting nuts (par. 53c).
40		<i>Hardware frame, attachments, and paint.</i> Inspect these items paying particular attention to springs. Make a general inspection of the frame including stakes, brake lines, landing gear, spare wheel and tire carrier, and stowage box. Examine condition of paint and legibility of markings, and data and service plates.
40		Tighten spring U-bolts and rebound clips (par. 86).
43		<i>Kingpin, fifth wheel upper plate.</i> Inspect kingpin and upper plate. Look particularly for security of mountings and adequate lubrication. Tighten assembly and mounting bolts.

Table III. Organizational Mechanics or Maintenance Crews C and D Preventive-Maintenance Services—Continued.

Intervals		Procedure
D (6 months or 6,000 miles whichever occurs first)	C (1,000 miles)	
		<p style="text-align: center;">EQUIPMENT</p> <p>Visually inspect semitrailer publications, including Standard Form 91 and DA Form 461.</p> <p style="text-align: center;">UNUSUAL CONDITIONS</p> <p>Maintenance operations and road test as prescribed under usual conditions will apply equally well under unusual conditions for operations for all occasions except in extreme-cold weather. Intervals are necessarily shortened in extreme-cold weather servicing and maintenance. Semitrailers subjected to salt-water immersion or complete submersion are evacuated to ordnance maintenance unit as soon as possible after exposure.</p>

Section IV. TROUBLESHOOTING

45. Scope

a. This section contains troubleshooting information and tests for locating and correcting some of the troubles which may develop in the semitrailer. Troubleshooting is a systematic isolation of defective components by means of an analysis of vehicle trouble symptoms: testing to determine the defective component and applying the remedies. Each symptom of trouble given for an individual unit or system is followed by a list of probable causes of the trouble and suggested procedures to be followed.

b. This manual cannot cover all possible troubles and deficiencies that may occur under the many conditions of operation. If a specific trouble, test, and remedy therefor, is not covered herein, proceed to isolate the system in which the trouble occurs and then locate the defective component. Use all the senses to observe and to locate troubles. Do not neglect use of any test instruments, such as ohmmeter, voltmeter, ammeter, test lamp, hydrometer, and pressure and vacuum gages that are available. Standard automotive theories and princi-

ples of operation apply. Question vehicle crew to obtain maximum number of observed symptoms. The greater the number of symptoms of troubles that can be evaluated, the easier will be the isolation of the defective system and components thereof.

46. Brakes

a. *General.* In analyzing trouble with the braking system of the unit, it is especially important to localize the cause because of the complexity of the system. It must be remembered that the symptom may be the end result of a defect existing on the towing vehicle instead of the semitrailer. By the elimination of one possible general source of trouble after another, and then eliminating specific possibilities in the affected portion of the system, the actual cause of the trouble may be isolated and corrected.

b. *Brakes Will Not Release.*

(1) *Emergency relay valve in applied position.*

(a) Build up pressure in semitrailer brake system, if semitrailer is coupled.

(b) Open drain cock (fig. 12) on semitrailer air reservoir, if semitrailer is uncoupled.

(2) *Intervehicular air hose improperly connected to towing vehicle or semitrailer.* Connect couplings properly (par. 31b(4)).

(3) *Brake valve on towing vehicle in applied position.* Move brake valve to released position,

(4) *Restriction in lines or hose.* Check and clean all lines and hose.

(5) *Shutoff valves closed on towing vehicle.* Open valves.

(6) *Weak or broken brake shoe tension spring.* Replace spring (pars. 57a and d (M269 and M270) and TM 9-1827C (M270A1)).

c. *No Brakes or Weak Brakes.*

(1) *Shutoff valves closed on towing vehicle.* Open valves.

(2) *Intervehicular air hose improperly connected to towing vehicle or semitrailer.* Connect couplings properly (par 31b(4)).

(3) *Semitrailer air reservoir drain cock open.* Close drain cock (fig. 12).

(4) *Low air pressure.* Check air pressure gage on towing vehicle. Make leakage tests (pars. 60c, 61b, 62a, 63a, and 65). Check for restriction in air lines.

(5) *Defective emergency relay valve.* Make serviceability tests (par. 60b).

- (6) *Clogged air filter.* Clean or replace element (par.10/).
 - (7) *Air in hydraulic system (M270A1).* Bleed hydraulic system (par. 66b).
 - (8) *Leaks in hydraulic system (M270A1).* Locate leak. Tighten connections or replace broken lines.
 - (9) *Grease on brake lining.* Replace brake shoe (par. 57a and d (M269 and M270) and TM 9-1827C (M270A1) and check and replace oil seal, if damaged or worn (par. 53a(3)).
 - (10) *Worn Brake lining.* Adjust brakes (par. 56).
 - (11) *Worn-out brake lining.* Replace brake shoes (par. 57a and d (M269 and M270) and TM 9-1827C (M270A1)).
 - (12) *Defective brake air chamber.* Make serviceability tests (pars. 62a and 63a).
 - (13) *Defective brake wheel cylinder (M270A1).* Inspect brake wheel cylinders (TM 9-1827C).
 - (14) *Defective or ineffective hydraulic master cylinder (M270A1).* Make brake air chamber push rod travel test (par. 62b). Replace defective master cylinder (pars. 62c and d), or brake air chamber (par. 62c and d).
 - (15) *Defective brake camshaft follower roller (M270 and M269) .* Notify ordnance maintenance personnel.
- d. *Slow Brake Application or Slow Release.*
- (1) *Low air pressure.* Check air pressure gage on towing vehicle. Make leakage tests (pars. 60a, 61a, 62a 63a, and 65). Check for restriction in air lines.
 - (2) *Restriction in air lines.* Look for bent or dented air lines.
 - (3) *Clogged air filter.* Clean or replace element (par. 10f).
 - (4) *Defective emergency relay valve.* Make serviceability tests (par. 60 b).
 - (5) *Weak or broken brake shoe tension spring.* Replace spring (par. 57a and d (M269 and M270) and TM 9-1827C (M270A1)).
 - (6) *Air in hydraulic system (M270A1).* Bleed hydraulic system (par. 66 b).
 - (7) *Defective brake air chamber.* Make serviceability tests (pars. 62a and 63a).
 - (8) *Defective brake wheel cylinders (M270A1).* Inspect brake wheel cylinders and replace if necessary (TM 9-1827C).
 - (9) *Defective or ineffective hydraulic master cylinder*

(M270A1). Make brake air chamber push rod travel test (par. 62b), Replace defective master cylinder or brake air chamber (par. 62c and d).

- (10) *Defective brake camshaft follower roller (M270 and M269)*. Notify ordnance maintenance personnel.

e. *Grabbing Brakes.*

- (1) *Moisture in air filters, air reservoir, Or emergency relay valve.* Drain (pars. 59-61).
- (2) *Brakes out of adjustment.* Adjust (par. 56).
- (3) *Grease in brake lining.* Replace brake shoes (par. 57a and d (M269 and M270) and TM 9-1827C (M270A1)) and check and replace oil seal, if damaged or worn (par. 53a(3)).
- (4) *Loose or worn wheel bearings.* Adjust bearings (par. 53c(2)). If they cannot be adjusted properly, replace bearings (par. 53a (3)).
- (5) *Cracked, scored, or deformed brake drum.* Replace drum (par. 53d and e).
- (6) *Worn or loose brake lining.* Replace brake shoes (par. 57a and d (M269 and M270) and TM 9-1827C (M270A1)).
- (7) *Defective brake camshaft follower roller (M270 and M269)* Notify ordnance maintenance personnel.
- (8) *Defective brake wheel cylinders (M207A1).* Inspect brake wheel cylinders and replace if necessary (TM 9-1827C) .

f. *Brake Drag (One or More Brake Drums Running Hot).*

- (1) *Brakes adjusted too tightly.* Adjust brakes (par. 56).
- (2) *Weak or broken brake shoe tension spring:* Replace spring (par. 57a and d (M269 and M270), and TM 9-1827C (M270A1)) .
- (3) *Defective brake camshaft follower roller (M270 and M269).* Notify ordnance maintenance personnel.
- (4) *Defective brake wheel cylinder (M270A1).* Inspect brake wheel cylinder and replace if necessary (TM 9-1827C).
- (5) *Out-of-round brake drum.* Replace drum (par. 53d, e, f, and g).

47. Suspension

(fig. 9)

a. *General.* The suspension of the vehicle includes a number of units, the function of which are closely related. These units are the springs, axles and trunnion tube, brackets, connections, hubs, wheels, and tires. Any improper adjustment or opera-

tion of one of these may affect the functioning of others. In correcting a specific malfunction, it may be necessary to search for and correct the basic fault rather than to balance out or allow for the more apparent cause of the trouble.

b. Hard Pulling.

- (1) *Dragging brakes.* Adjust brakes (par. 56).
- (2) *Improper wheel bearing adjustment.* Adjust bearings (par. 53c(2)).
- (3) *Loose trunnion cross tube bracket bolts.* Tighten bolts. Notify ordnance maintenance personnel.
- (4) *Loose springs.* Aline springs. Tighten U-bolt nuts.
- (5) *Broken or disconnected torque rods.* Notify ordnance maintenance personnel.

c. Improper Spring Action.

- (1) *Loose U-bolts.* Tighten U-bolt nuts.
- (2) *Uneven load distribution.* Distribute load properly.
- (3) *Broken leaves, center bolts, or clips.* Notify ordnance maintenance personnel.
- (4) *Excessive flexibility.* Notify ordnance maintenance personnel.

d. Excessively Worn, Scuffed, or Cupped Tires.

- (1) *Improper tire pressure.* Inflate tires to proper pressure (par. 52a).
- (2) *Loose wheels.* Tighten wheel nuts and capnuts.
- (3) *Loose wheel hearings.* Adjust bearings (par. 53c (2)).
- (4) *Bent rim or wheel.* Replace wheel (par. 52b and c).
- (5) *Out of round brake drum.* Replace drum (pal. 53d and e).
- (6) *Broken or disconnected torque rods.* Notify ordnance maintenance personnel.

48. Landing Gear

a. General. The principal causes of failure of the landing gear to operate properly are lack of lubrication and misuse. Adequate lubrication is essential to good operation.

b. Difficulty in Turning Operating Handcrank.

- (1) *Lack of lubrication or improper lubricant used.* Refer to lubrication order (fig. 32) for proper lubricants. Remove lubricating fittings from gear boxes, legs, and handcrank and insert a wire as an oil gage to determine amount, type, and condition of lubricant in the unit.
- (2) *Bent crank shaft extension.* Replace or straighten shaft (pars. 68a and 69 b).

- (3) *Bent lower leg.* If bend is not readily apparent, check to determine whether lower leg centers in collar of upper leg, in various positions. If bent, notify ordnance maintenance personnel.
- (4) *Worn gears or bearings.* Notify ordnance maintenance personnel.
- (5) *Bent operating screw.* Disconnect connecting shaft (par.68b). Operate right leg with operating hand-crank and left leg with wrench on shaft to determine whether either leg binds at any point in its travel. If bent, notify ordnance maintenance personnel.

49. Lights

a. *General.* In locating the causes of the majority of lighting troubles on the semitrailer, the first steps are to determine whether the inoperative lamp is burned out and whether an adequate supply of current is reaching the lamp from the source on the towing vehicle. A tester or test lamp should be used to isolate the source of the trouble so that corrective measures can be taken.

b. *All Lamps Do Not Light.*

- (1) *Intervehicular cable not properly plugged into receptacles on semitrailer and towing vehicle.* Pull plugs out of receptacles and reinsert them fully into receptacles.
- (2) *Light switch on towing vehicle not adjusted properly.* Check setting of light switch.
- (3) *No current from towing vehicle.* Check circuit breaker and wiring on towing vehicle.
- (4) *Short circuit in wiring.* Check wiring for bare spots in insulation. Refer to wiring diagrams (figs. 24 and 25).
- (5) *Dirty or corroded contacts in receptacle or on plug.* Inspect contacts (TM 9-1825E).
- (6) *Dirty or corroded contacts in semitrailer wiring.* Inspect contacts (TM 9-1825E).

c. *One or More Lamps Will Not Light*

- (1) *Burned out lamp.* Replace lamp (pars. 72-75).
- (2) *Broken, grounded, or shorted cable, or loose cable connection.* Check cables for these conditions. Tighten, repair or replace defective cables. Clean connections.
- (3) *Damaged light assembly.* Replace or repair light assembly (pars. 72-75).

- (4) *Dirty or corroded lamp socket.* Remove lamp (pars. 72-75) and clean contacts.
- (5) *Dirty or corroded contact or receptacle or on plug.* Inspect contacts (TM 9-1825E).

d. *Dim or Flickering Lights.*

- (1) *Loose, dirty or corroded terminals.* Clean and tighten terminals.
- (2) *Poor or loose ground.* Clean and tighten terminals on short (ground) cable in back of receptacle (fig. 23) on semitrailer.
- (3) *Defective lamp.* Replace lamp (pars. 72-75).
- (4) *Dirty or corroded lamp socket or contact in receptacle or on plug.* Inspect contacts (TM 9-1825E).

50. Body and Equipment

Damage to body and equipment, such as broken deck planks, broken stakes, chains or chock blocks, or faulty spare wheel and tire carrier, is self-evident and means of correction are obvious to the personnel of the responsible echelon.

Section V. WHEELS, TIRES, HUBS, AND BRAKE DRUMS

51. General

The wheels and hub may be removed and installed as a unit or separately. The wheels are separated from the hub in changing tires and in making any major brake adjustment, repair, or replacement. Wheels and hubs may be removed as a unit for lubrication, for inspection of suspension, and other operations where brake adjustments are not necessary. For removal and installation of wheels and hubs as a unit, use greased sheet of metal or board and follow the procedures for removal and installation of hub and brake drum assembly (par. 53a and c).

52. Wheels and Tires

a. *Tire Inflation.* Standard inflation pressure for highway driving is 50 psi; for cross-country driving, 35 psi; for driving in sand, 15 psi. Pressure in all tires must be equal. When checking tire pressure, do not reduce pressure if tires are hot, unless pressure must be reduced to increase traction on ground, in cross-country driving, or in operation over sand.

b. *Removal of Wheels From Hub* (fig. 35). Jack up wheels enough to take part of the weight off tires. Loosen 10 wheel nuts (hex-head) which secure outer wheel. Jack up wheels

clear of ground and remove wheel nuts and outer wheel. Remove cap nuts and remove inner wheel.

Note. Cap nuts and wheel nuts on right side (marked R) have right-hand threads and those on the left side (marked L) have left-hand threads. Nuts must be turned in opposite direction to normal forward rotation of wheel to be loosened and removed.

If greased sheet of metal or board is placed under tires and wheels lowered to rest on greased surface, wheels can be slipped off studs with a minimum of effort.

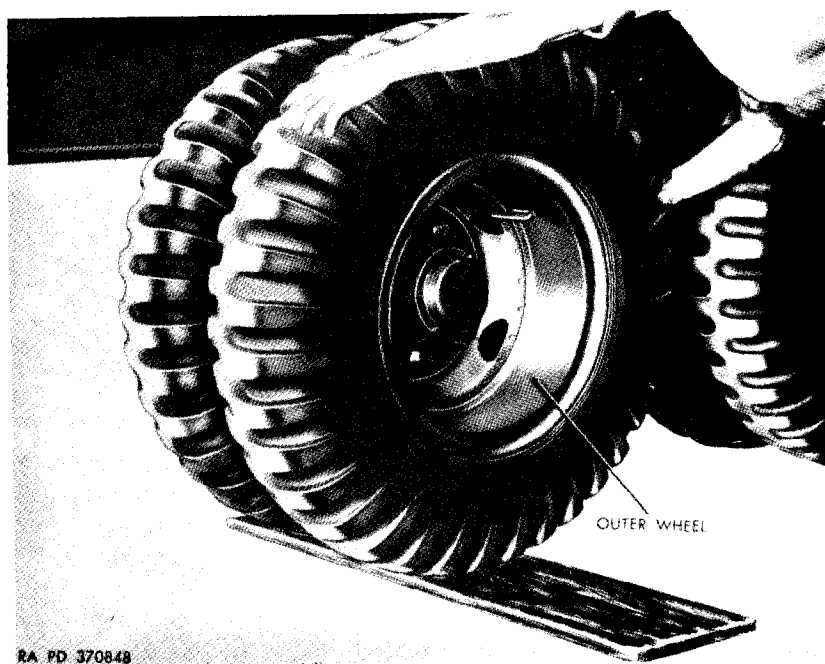

Figure 35. Removing outer wheel.

- (1) *Remove split lock ring.* Deflate tire by unscrewing tire valve cap and using small end to unscrew valve core. With tire fully deflated, locking should be loose on rim. If it adheres to rim, tap it with mallet to break it loose. Place end of tire tool between ends of lockring or between lockring and rim near one end of locking (fig. 36) and pry from its groove in rim. It will prove helpful to place tire iron or chisel under the pried-up locking to hold it until next successive portion is pried from place.

- (2) *Remove tire.* Turn wheel over, placing it on blocks or other objects to raise tire about 6 inches from ground. Force tire valve stem into tire through slot in wheel rim. Press and pry one tire bead and then the other from wheel rim. Weight of tire, as it hangs from blocked up wheel, will aid in its removal. Standing on casing will help force it from ri.n. Remove tube from tire.

d. *Installation of Tire On Wheel.*

- (1) *Mount tire.* Install tube in tire. With beaded edge of wheel rim downward, place wheel on blocks or other objects sufficiently high to raise rim an inch or more off the ground. Lower tire into place on rim, with valve stem alined with slot in wheel rim. Stand on tire on side opposite stem to force tire onto rim.
- (2) *Install split lock ring.* Place split locking on wheel. Start an end of ring under bead of rim by standing on ring and stamp it into groove in rim (fig. 37)

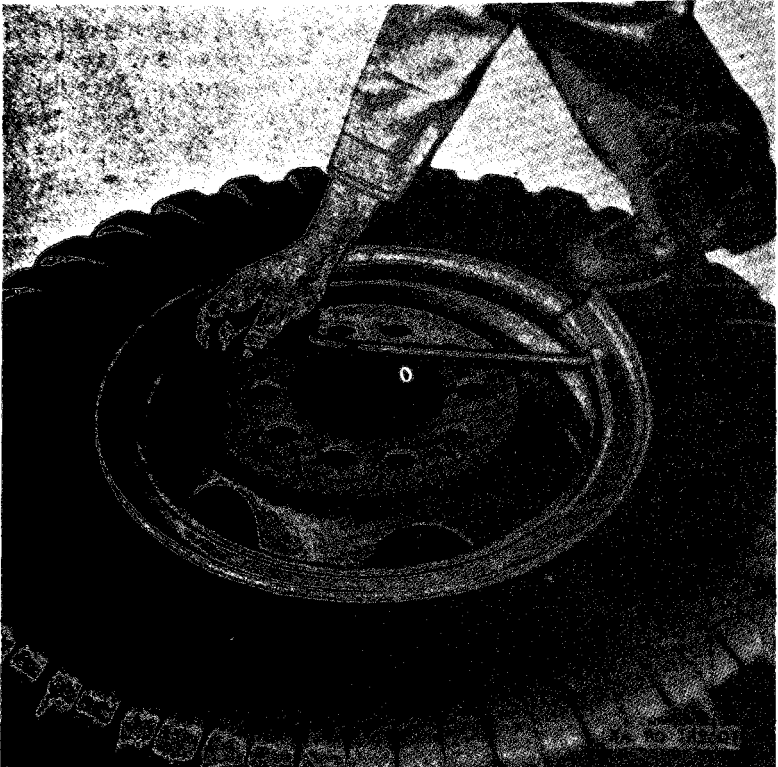

Figure 36. *Prying splitlock ring from wheel.*

with heel. As portion of ring goes into place, stand on that portion and stamp ring progressively into place. Inflate tire slightly and with a heavy mallet pound casing all around to make tube fit smoothly inside casing. Inflate tire to proper pressure (a above)

e. *Install Wheel On Hub*. Install inner wheel on 10 hub studs with convex side of wheel facing out. Install 10 wheel capnuts (square-head) tightening them alternately on opposite sides to insure that they are tightened evenly. Install outer wheel over 10 wheel capnuts, convex side facing in, making certain that valve stem of outer wheel is not over valve stem of inner wheel. Install 10 wheel nuts (hex-head) on wheel capnuts and tighten alternately on opposite sides. All nuts should be gone over twice to make sure they are seated securely. Lower wheels to ground and check tightness of cap and wheel nuts again.

53. Hub and Brake Drum

a. *Removal of Hub Brake from Axle.*

(1) *Remove wheels from hub*. Refer to paragraph 52b).

Note. Wheels and hubs may be removed as a unit for lubrication and other operations where brake adjustments are not necessary.

(2) *Remove wheel bearing adjusting nuts* Remove six cap screws and lockwashers (M270A1) or 10 cap screws and lockwashers (M270 and M269) which secure hub cap (A, fig. 51) to hub. Remove hub cap and gasket. Using wrench 41-W-3825-72 (figs. 31 and 38) remove wheel bearing jamnut. Slide off nut-locking key washer from axle. With opposite end of wrench 41-W-3825-72, remove wheel bearing adjusting nut.

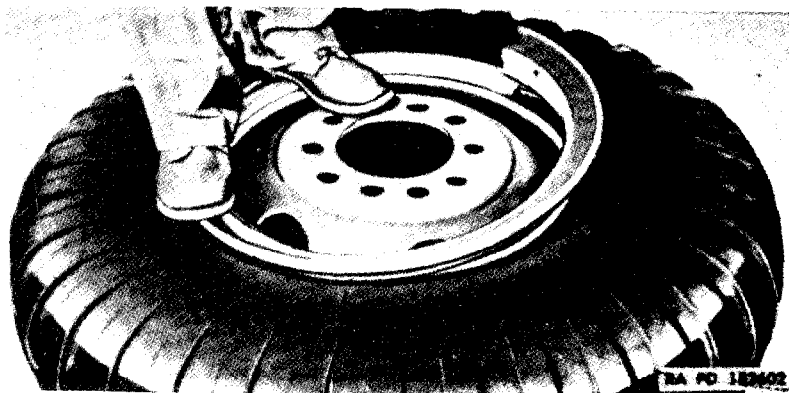

Figure 37. Forcing split lock ring into groove in wheel rim.

- (3) *Remove bearings.* Move hub and brake drum assembly on axle spindle to loosen outer cone and roller bearing assembly (N, fig. 51). Remove cone and roller bearing assembly from axle. Inner cone and roller bearing assembly (G, fig. 51) is removed with hub. With offset screwdriver, remove oil seal and then remove inner cone and roller bearing assembly from hub. Do not remove bearing cups from hub unless they require replacement. If oil seal wiper on axle requires replacement, notify ordnance maintenance.

b. Clean and Lubricate Hub and Bearings. Wash cone and roller bearing assemblies, hubs, and axle spindles with mineral spirits paint thinner or dry-cleaning solvent. Use brush to remove old lubricant. Inspect bearings, cups in hubs, and hubs for indication of wear or damage and replace parts if not serviceable. Replace bearing cups (h and i below) if worn, distorted or scored. Inspect hub for cracks or damage. Lubricate bearings and hubs (par. 39c(3)).

c. Installation of Hub and Brake Drum on Axle.

- (1) Install bearings. Position inner cone and roller bear-

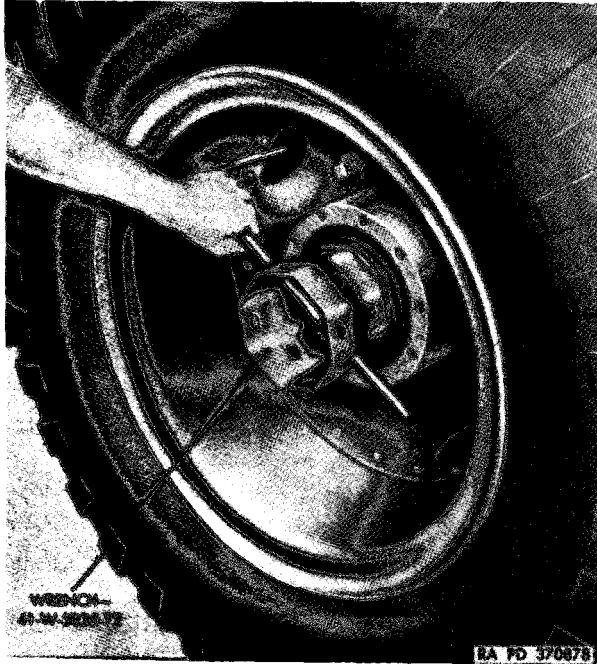

Figure 38. Removing or installing wheel bearing jamnut using wrench 41-W-3825-72.

ing assembly (G, fig. 51) in cup. Press oil seal into place.

Caution: Install seal carefully to prevent damage. If tapped into place with hammer, use block of wood or old oil seal as driver. Do not hammer directly on seal. As seal is being forced into place, note that it remains level with surface of hub. If slightly out of alinement, tap on high side. If position becomes extreme, remove seal and start over.

Position hub on axle and move into place carefully, making sure seal slips over wiper without damage to seal packing. Keep hub square with axle while slipping into place. Position outer cone and roller bearing assembly (N, fig. 51) in hub and install bearing adjusting nut.

- (2) *Adjust bearings.* While turning hub, tighten wheel bearing adjusting nut using wrench 11-W-3825-72 until hub binds on axle spindle. Back off nut about 1/8 turn. Check adjustment by grasping drum and attempting to rock it on axle spindle. If bearings are properly adjusted, movement of brake drum in relation to top edge of brake backing plate will scarcely be visible, with drum turning freely. A slight drag, caused by lubricant and grease seal will be apparent in well adjusted bearings.

Note. Bearings may be adjusted without removing wheels from hub.

- (3) *Lock wheel bearing jamnut.* Slide key washer onto axle spindle. Adjust wheel bearing adjusting nut so that pin of nut will mate with nearest hole in key washer. Check bearing adjustment again. If movement of adjusting nut has interfered with original adjustment, withdraw key washer so hole clears pin and turn adjusting nut so pin will mate with next hole in key washer. to give better adjustment. Install wheel bearing jamnut using wrench 41-W-3825-72 (figs. 31 and 38). Tighten nut to bear against key washer. Check wheel bearing adjustment again. Install hub cap and gasket and secure with six 5/16 x 1/2 cap screws and 5/16inch lockwashers (M270A1), or ten 1/2 x 1 1/2 cap screws and 1/2-inch lockwashers (M270 and M269).

- (4) *Install wheels on hub.* Refer to paragraph 52e.

Note. The following hub and brake drum operations are to be performed if required, after wheels have been removed from hub

(par. 52b), and hub and brake drum have been removed from axle (a above).

Note. The key letters shown in parentheses in d and e below are in figure 52.

d. Removal of Brake Drum from Hub (Semitrailer M270A1). Remove ten hex-head bolts (B), lockwashers (E), and, hex nuts (F) that secure brake drum (J) and inspection hole cover (D) to adapter (C). Remove inspection hole cover. Remove brake drum from adapter. Remove ten wheel studs (A) that secure adapter to hub (G). Studs have serrated shank causing them to be retained in adapter and hub unless forced out. Press or drive out studs then separate adapter from hub.

e. Installation of Brake Drum on Hub (Semitrailer M270A1) (fig. 52). Position adapter (C) on hub (G) and secure with ten wheel studs (A). Use care in replacing studs by matching serrations in studs with serrations in brake drum adapter and hub to preserve good fit. Position brake drum (J) on brake drum adapter and inspection hole cover (D) on drum and adapter. Secure cover and brake drum with ten 7/16 x 1½ hex-head bolts (B), 7/16-inch lockwasher (E), and 7/16-inch hex nuts (F).

f. Removal of Brake Drum from Hub (Semitrailers M270 and M269). Remove ten hex-head bolts, lockwashers, and hex nuts that secure drum, inspection hole cover, and oil slinger to brake drum adapter. Remove inspection hole cover from drum and separate drum and oil slinger from adapter. Remove ten hex-head bolts and lockwashers that secure adapter to hub. Remove adapter from hub. Ten wheel studs extending from flange of hub have serrated shanks causing them to be retained in hub, unless forced out. If damaged, press or tap out studs.

g. Installation of Brake Drum on Hub (Semitrailers M270 and M269). If wheel studs were removed from flange of hub, install new studs. Use care in replacing studs by matching serrations in studs with serrations in flange of hub to preserve good fit. Position adapter on flange of hub and secure adapter with ten ½ x 1¾ hex-head bolts and ten ¾-inch lockwashers. Slip brake drum over hub and against outer surface of flange of adapter. Apply a thin coating of Permatex No. 1 to flange of oil slinger. From a position inside drum, position oil slinger, concave side toward hub, on inner surface of flange of adapter. secure drum and oil slinger to adapter with nine 7/16 x 1½, hex-head bolts, nine 7/16-inch lockwashers, and nine 7/16-inch hex nuts. Position inspection hole cover over inspection hole

in brake drum and secure with remaining 7/16 x 1 1/2 hex-head bolt, 7/16-inch lockwasher, and 7/16-inch hex nut.

h. Removal of Bearing Cup From Hub. With hub placed on blocks, remove bearing cup from hub, using remover and replacer 41-R-2374-805 (fig. 39). Turn hub over and repeat the process to remove the opposite cup.

i. Installation of Bearing Cup in Hub. With hub placed on a solid surface, position cup over cup seat and install, using remover and replacer 41-R-2374-805 (fig. 39). Make certain the cup is fully seated. Turn hub over and repeat procedure for opposite cup.

Section VI. SUSPENSION

54. Coordination with Ordnance Maintenance Unit

Replacement of axle, spring, and/or trunnion cross tube assemblies is normally an ordnance maintenance operation, but may be performed in an emergency by the using organization, providing authority for performing this replacement is obtained from the appropriate commander. A replacement axle, spring, or trunnion cross tube, and tools needed for the opera-

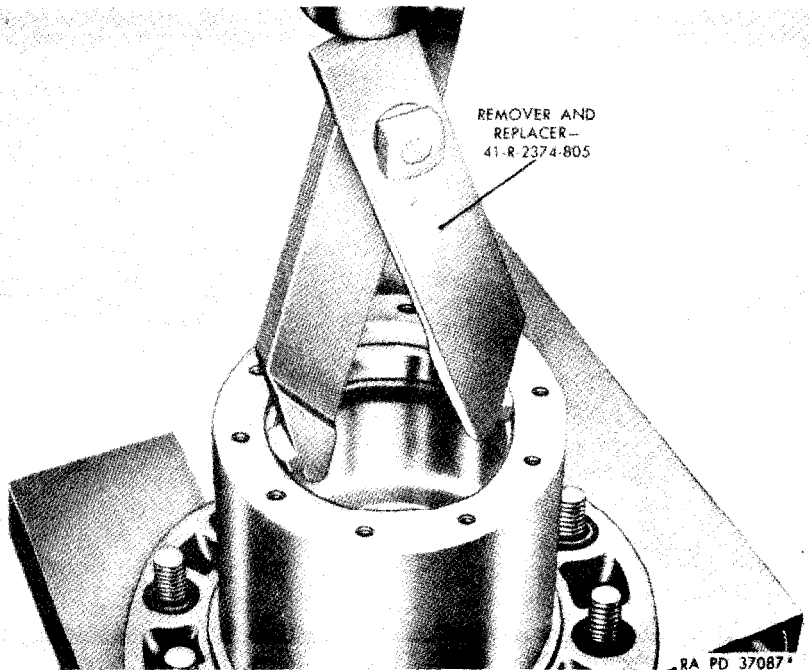

Figure 39. Installing outer bearing cup using removal and replace 41-R-2374-805.

tion which are not carried by the using organization, and any special instructions, regarding accessories etc., may be obtained from the supporting ordnance maintenance unit. For information on removing axle, spring, and trunnion cross tube assemblies, refer to paragraphs 85 through 89.

55. Spring Seat

Note. The key letters shown in parentheses below are in figure 53.

a. Removal of Spring Seat.

- (1) Remove wheels (par. 52b) from side of semitrailer to be worked on.
- (2) Support weight of semitrailer by jacking up trunnion cross tube at end from which spring seat is to be removed.
- (3) Remove two hex nuts (Z) and lockwashers (Y) from each U-bolt (M).
- (4) Remove two U-bolts (M) and lift off spring saddle (L).
- (5) Remove hex-head bolt (P) and lockwasher (N) from each side of spring seat (K).
- (6) Raise each axle sufficiently to detach spring from spring seat (K).
- (7) Remove six cap screws (A) and lockwashers (B) and remove seat cap (C) and cap gasket (D). Discard gasket.
- (8) Remove bearing jam nut (E) using wrench 41-W-3825-72 (fig. 31).

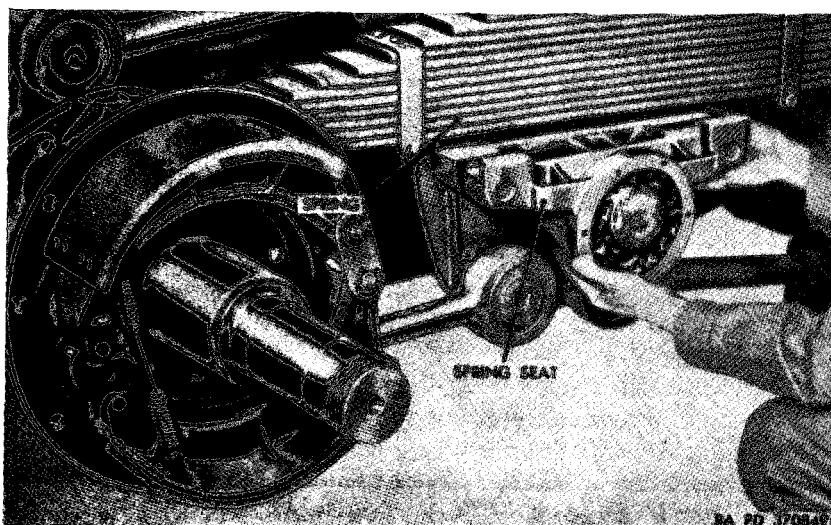

Figure 40. Removing spring seat.

- (9) Remove key washer (F) and, using the opposite end of wrench 41-W-3825-72 remove bearing adjusting nut (G).
- (10) Remove outer cone and roller bearing assembly (II) from trunnion cross tube.
- (11) Remove spring seat (K) by using a slight rotary motion while carefully sliding seat from trunnion cross tube (fig. 40). Inner cone and roller bearing assembly (W) will remain in seat.

b. Removal of Oil Seal and Inner Cone and Roller Bearing Assembly.

- (1) Remove oil seal (Q) from spring seat (K). Discard oil seal.
- (2) Remove inner cone and roller bearing assembly (W) from spring seat (K) .
- (3) Remove felt seal retainer (S), felt seals (T), and seal retaining washer (U) from trunnion cross tube with a standard puller. Do not remove oil seal wiper (R) from trunnion cross tube unless it is damaged.

Note. Replacement of the oil seal wiper is normally an ordnance maintenance operation, but may be performed in an emergency by the using organization, providing authority for replacement is obtained from the appropriate commander. Tools needed for the operation which are not carried in the using organization may be obtained from the supporting ordnance maintenance unit, Refer to paragraph 85e for replacement procedures.

c. Clean and Lubricate Spring Seat and Bearings. Clean seat, tube, and bearings with mineral spirits paint thinner or dry-cleaning solvent. Use brush to remove old lubricant. Inspect seat for cracks and damage which might impair its serviceability. Inspect bearing cups and replace (par. 53h and i) if worn, distorted, or scored. Apply thin coating (not over 1/16-inch) of bearing lubricant to inside of seat and to tube. Inspect roller assemblies for serviceability and lubricate as specified in lubrication order (fig. 32).

d. Installation of Oil Seal and Inner Cone and Roller Bearing Assembly.

- (1) If oil seal wiper (R) was removed from trunnion cross tube, install a new wiper (par. 85e).
- (2) Install seal retaining washer (U), two felt seals (T), and felt seal retainer (S) on trunnion cross tube.
- (3) Install inner cone and roller bearing assembly (W) in larger diameter end of spring seat (K).
- (4) Install a new oil seal (Q) over installed inner cone and roller bearing assembly (W). Using a wooden

block or discarded oil seal, press oil seal (Q) into place.

e. Installation of Spring Seat.

- (1) Slide assembled spring seat (K) onto trunnion cross tube. Hold seat level with tube and with rotary motion, work seat into position carefully so that opening in seat will slip over felt seal retainer (S) and oil seal will slip over oil seal wiper (R) without damage. Seat should cover felt seal retainer when fully positioned.
- (2) Install outer cone and roller bearing assembly (H) on trunnion cross tube.
- (3) Install bearing adjusting nut (G) on trunnion cross tube. Using wrench 41-W-3825-72 (fig. 31), tighten nut sufficiently to force inner cone and roller bearing assembly (W) into place and then back off nut until seat can be turned freely by hand, but without lateral movement of seat being apparent. Some drag will be noted in turning a well adjusted seat due to oil and lubricant in bearing cones.
- (4) Install key washer (F) on trunnion cross tube, mating pin in bearing adjusting nut (G) in hole of washer. Install bearing jamnut (E) on trunnion cross tube using opposite end of wrench 41-W-3825-72 (fig. 31).
- (5) Install a new cap gasket (D) and seat cap (C) on spring seat and secure with six 5/16 x 1/2 cap screws (A) and 5/16-inch lockwashers (B).
- (6) Lower each axle sufficiently to seat spring in spring seat (K). Spring center bolt must fit into recess in top of spring seat.
- (7) Install but do not tighten one 1¼ x 5 8/5 hex-head bolt (P) and one 1¼-inch lockwasher (N) in each side of spring seat (K).
- (8) Install spring saddle (L) on top of spring. Install two U-bolts (M) over saddle and down sides of spring.
- (9) Install two 1-inch lockwashers (Y) and 1-inch hex nuts (Z) on each U-bolt (M). Tighten nuts sufficiently to bring spring down into spring seat. With spring and seat in this position, tighten each 1¼ x 5 5/8 hex-head bolt (P) ((7) above).
- (10) Remove jacks from trunnion cross tube.
- (11) Install wheels (par. 52b).

Section VII. BRAKES

56. Brake Adjustments

a. General. Brake adjustment to compensate for normal wear is termed "minor adjustment." Following a rebuild or when new linings are installed, each brake shoe must be adjusted to center brake shoe arc in relation to the brake drum. This is called "major adjustment."

Note. Always check wheel bearing adjustment (par. 53c(2)) before adjusting brakes. A satisfactory brake adjustment cannot be obtained unless wheel healings are in proper adjustment. Do not adjust brakes when drums are hot.

b. *Semitrailer M270A1* (fig. 41).

- (1) *General.* Two adjusting shafts protrude from back of brake spider and dust shield inclosure of the brake assembly. Each shaft provides the lining clearance adjustment for one brake shoe.

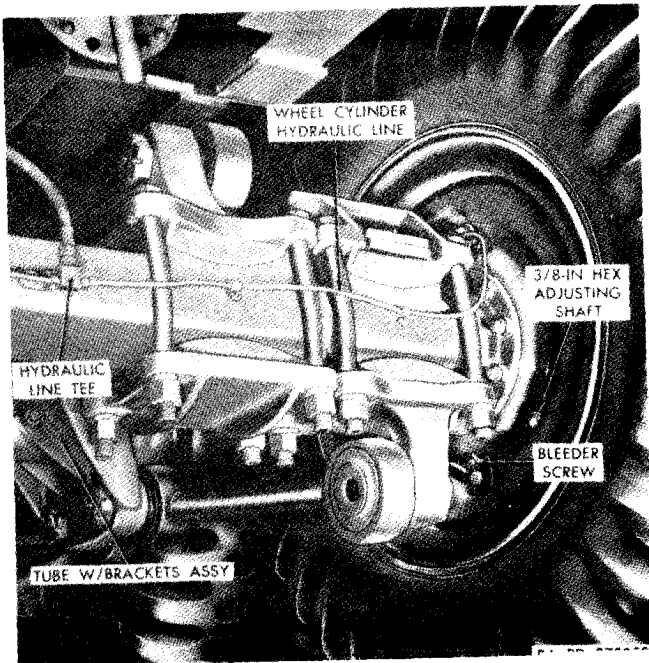

Figure 41. Brake adjusting shaft-semitrailer M270A1.

- (2) *Brake lining clearance adjustment.*
- (a) Release brakes on towing vehicle. Jack up axle on semitrailer so that wheels may be rotated freely.
- (b) Engage each adjusting shaft with a 3/8-inch hex or

end wrench. Rotate each shaft in direction of forward wheel rotation to decrease brake lining clearance until lining drags on drum. Check drag on drum by rotating wheel in forward direction of rotation. Make a brake application to be certain shoes are centered. Readjust if required.

(c) Relieve drag on drum by rotating each adjusting shaft in opposite direction. Then rotate shaft one complete turn (two complete turns with a new lining) to provide correct lining clearance.

(d) Adjust both shoes in each brake of semitrailer to as near same lining-to-drum clearance as possible.

c. *Semitrailers M270 and M269.*

(1) *Minor adjustment.* Minor adjustment of brakes can be performed without removing wheels from hubs.

(a) Release brakes of towing vehicle. Jack up axle on semitrailer so that wheels may be rotated freely.

(b) With a wrench, depress spring lock on adjusting worm shaft (fig. 42) of brake slack adjuster and turn worm shaft until wheel or brake drum cannot be turned freely by hand. Back off on shaft just enough so wheel or drum can be turned freely by hand. After completing adjustment, make certain

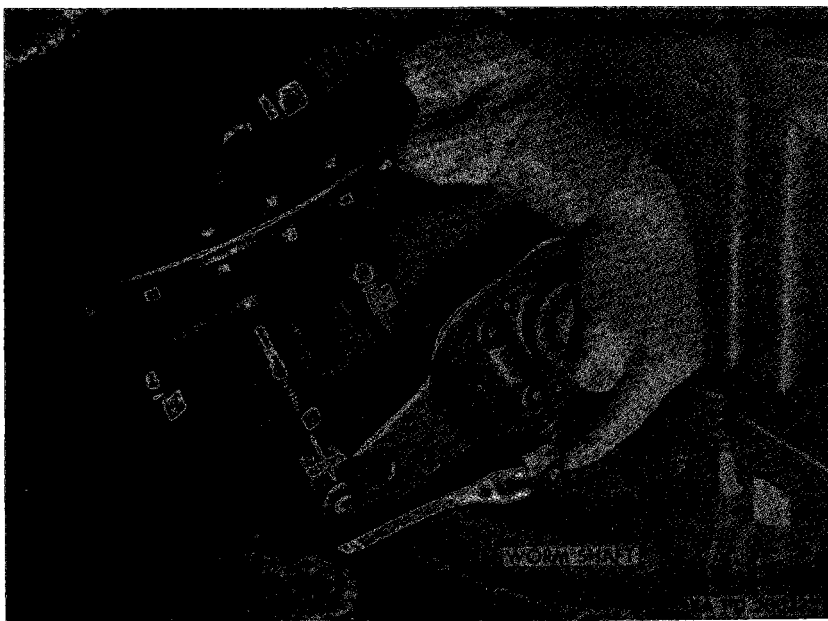

Figure 42. Minor adjustment of brakes-semitrailers M270 and M269.

that head of shaft is in position to fit into slot of lock and that lock is in position to prevent further turning on shaft.

- (c) Repeat this procedure with brake at opposite end of same axle. Make adjustment of each brake as uniform with other as possible. Repeat procedure on brakes on other axle.
- (2) *Major adjustment.* Wheels must be removed from hub before making major adjustment to give access to inspection hole in drum.
- (a) Remove wheels from hub (par. 52b). Remove nut and lockwasher, which secure inspection hole cover (fig. 19) over inspection hole in brake drum.
 - (b) Loosen locknut on brakeshoe anchor pin (fig. 44). Rotate drum until opening is $1\frac{1}{2}$ inch from end of one brake lining, nearest anchor pin. Insert 0.005-inch feeler gage (fig. 43) between surface of drum and brake lining and with wrench, turn anchor pin until 0.005-inch clearance is obtained. Hold anchor pin with one wrench and with a second

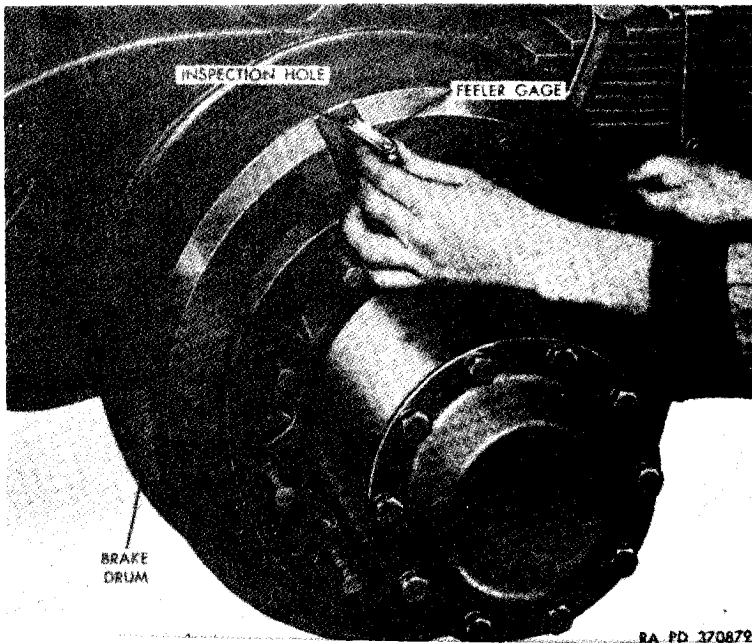

Figure 43. Checking brake lining clearance with feeler gage—*semitrailers M270 and M269.*

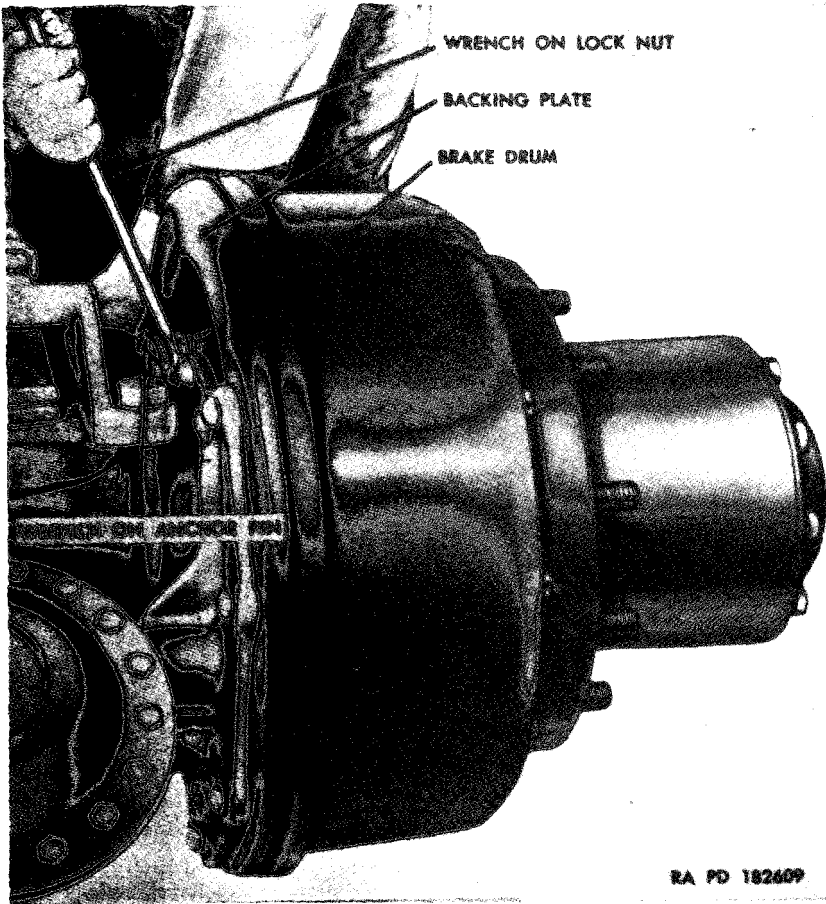

Figure 44. Making brake major adjustment at anchor pins-semitrailers M270 and M269.

- wrench tighten locknut (fig. 44). Check clearance again.
- (c) Rotate drum until inspection hole is $1\frac{1}{2}$ inch from other end of same brakeshoe, nearest crankshaft. Insert 0.010 inch feeler gage and turn worm shaft (fig. 42) of slack adjuster until 0.010 inch clearance is obtained. Check clearance ((b) above) at other end of brakeshoe.
 - (d) Repeat procedures outlined in (b) and (c) above on each shoe of each brake. Check all anchor pin lock nuts and make certain worm shaft of each slack adjuster is locked.
 - (e) Install wheels (par. 52e).

57. Internal Brake Mechanisms (Semitrailers M270 and M269)

a. Removal of Brake Shoes.

Caution: Make certain that all air pressure has been relieved from braking system by opening drain cock (fig. 12) on air reservoir.

- (1) Remove wheels (par. 52b).
- (2) Remove hub and brake drum (par. 53a).
- (3) Remove shoe tension spring (fig. 16).
- (4) Remove C-washers and anchor pin strap from anchor pins (fig. 16). Remove brakeshoes.

b. *Removal of Brake Camshaft.* Using snap ring pliers, remove snap ring from splined end of camshaft and slide off washer (fig. 18). Disconnect slack adjuster (fig. 18) from brake air chamber yoke by removing cotter pin and clevis pin. Slide off slack adjuster, spacer and two washers. Withdraw camshaft from outer side of backing plate (fig. 16) and remove washer from camshaft. Mark camshaft to insure installation at original location.

c. Installation of Brake Camshaft.

- (1) Place washer (fig. 18) on camshaft. Following marks made at removal (b above), insert camshaft into mounting bracket from outer side of backing plate. Slide camshaft into place carefully, using rotary motion, to position it in bearings and seals without damage.
- (2) Install two washers and spacer over splined end of camshaft and against camshaft mounting bracket.
- (3) Apply a thin coat of oil on splines of camshaft and slide slack adjuster (fig. 18) into position. A slight rotary action of slack adjuster will allow splines in slack adjuster to mesh with splines on camshaft.
- (1) Position washer on splined end of camshaft and install snap ring.
- (5) Turn worm shaft (fig. 42) of slack adjuster until arm can be positioned in brake air chamber yoke. Coat $1/2 \times 1 \ 13/64$ clevis pin with light film of oil and attach arm of slack adjuster to yoke (fig. 18). Secure clevis pin with $1/8 \times 7/8$ cotter pin.

d. Installation of Brakeshoes (fig. 16).

- (1) Coat anchor pins and anchor pin strap with light film of grease. Install shoes on anchor pins. Install strap on anchor pins and secure with C washers.
- (2) Attach shoe tension spring to spring anchor pins near

roller end of brakeshoe, making certain end hooks of spring are seated in grooves in pins.

- (3) Loosen anchor pins by backing off anchor pin lock-nuts and turn anchor pins to give minimum distance between ends of brakeshoes at this point. Turn worm shaft of slack adjuster to give minimum distance between roller ends of brakeshoes.
- (4) Install hub and brake drum (par. 53c).
- (5) Adjust brakes with "major adjustment (par. 56c(2)).
- (6) Install wheels (par. 52e).

58. Internal Brake Mechanisms (Semitrailer M270A1) (fig. 15)

a. Removal.

- (1) Remove wheels (par. 52b).
- (2) Remove hub and brake drum (par. 53a).
- (3) Remove wheel cylinder hydraulic lines (fig. 41) at wheel cylinders.
- (4) Remove 10 safety nuts (rear of axle flange) and cap screws which secure brake assembly to flange of axle. Remove brake assembly from axle.

b). Installation,

- (1) Position brake assembly on axle and against axle flange. Rotate brake assembly until one wheel cylinder is at top center. Aline holes in brake dust shield and axle flange and install ten 9/16 x 17/8 cap screws and ten 9/16-inch safety nuts. Tighten nuts.
- (2) Assemble wheel cylinder hydraulic lines (fig. 41) to wheel cylinders.
- (3) Install hub and brake drum (par. 53c) and adjust brakes (par. 56 b).
- (4) Bleed brake system (par. 66b).
- (5) Install wheels (par. 52e).

59. Air. Filter (fig. 45)

a. Drainage of Moisture from Air Filter. To drain accumulations of moisture from air filter, remove drain plug. Replace plug after draining.

b.. Removal. Unscrew tube connectors and draw air line away from filter. Remove two hex nuts and lockwashers from U-bolt which secures filter to chassis frame cross member. Remove U-bolt and filter.

c. Installation. Position air filter on cross member of chassis

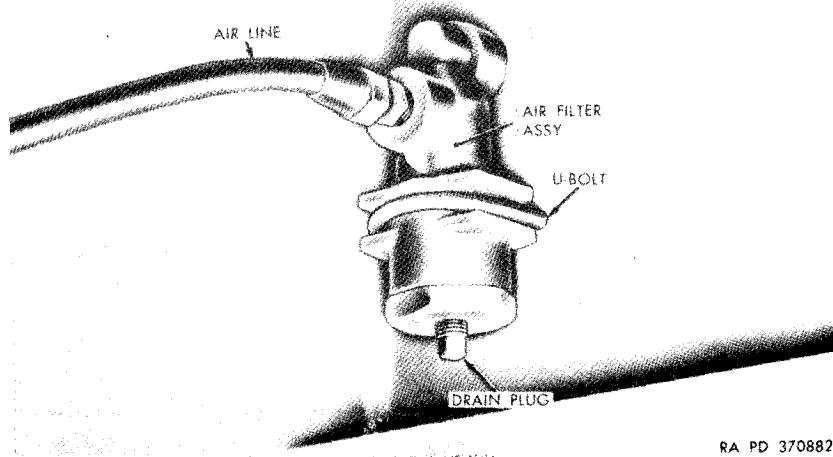

RA PD 370882,

Figure 45. Air filter-installed view.

frame by aligning U-bolt seat of filter with holes in cross member. Place U-bolt over filter and through holes in cross member. Install two $\frac{1}{4}$ -inch lockwashers and $\frac{1}{4}$ -inch hex nuts on U-bolt and tighten. Draw air line ends to openings on filter and tighten tube connectors.

60. Emergency Relay Valve

a. Drainage of Moisture from Emergency Relay Valve. To drain accumulated moisture, remove drain plug (fig. 13). Install plug after draining.

b. Operating Tests.

- (1) With air brake system of semitrailer connected (par. 31b(3)), apply brakes and check to be sure that brakes of all semitrailer wheels apply properly.
- (2) Release brakes and check to be sure air pressure is exhausted promptly through exhaust check valve.
- (3) With brake system fully charged, close shutoff cock in emergency line on towing vehicle and disconnect air hose coupling (fig. 10) tagged EMERGENCY. Check to be sure semitrailer brakes apply automatically.
- (4) Connect air hose coupling tagged EMERGENCY, open shutoff cock on towing vehicle, and check to be sure brakes release automatically.

c. *Leakage Tests.*

- (1) With air brake system connected (par. 31b(3)), apply soapy water to flanges which hold diaphragm (fig. 13), and to service air line coupling. No leakage is permitted. Tighten nuts on flanges and tighten coupling as required.
- (2) Coat exhaust check valve (fig. 13) with soapsuds. Apply brakes.
- (3) Release brakes and apply coating of soapsuds to exhaust port.
- (4) With emergency relay valve in emergency position (b (3) above), coat exhaust port with soapsuds.
- (5) Leakage tests ((2)-(4) above) must not exceed a 1-inch bubble in 3 seconds. If excess leakage is found, replace emergency relay valve (d below).

d. *Semitrailer M27A1* (fig. 13).

Caution: Before attempting to remove components of air lines, release air pressure from system by opening drain cock on air reservoir.

- (1) *Removal.* Disconnect service and emergency air lines, and air lines to brake air chambers from elbows at emergency relay valve. Disconnect connector of air line leading to reservoir at emergency relay valve. Remove two hex-head bolts, lockwashers, and hex nuts which secure emergency relay valve to cross member of chassis frame. Lift off emergency relay valve.
- (2) *Installation.* Position emergency relay valve on cross member and secure with two 3/8 x 1 hex-head bolts, 3/8-inch lockwashers, and 3/8-inch hex nuts. Position air line to reservoir on emergency relay valve and tighten connector. Connect air lines leading to brake air chambers and emergency and service air lines to elbows at emergency relay valve. Brake operating tests and leakage tests (b and c above).

e. *Semitrailers M270 and M269* (fig. 12).

Caution: Before attempting to remove components of air lines, release air pressure from system by opening drain cock on air reservoir.

- (1) *Removal.* Disconnect service and emergency air lines, and four hose assemblies leading to brake air chambers, at elbows in emergency relay valve. Remove three hex nuts and lockwashers which secure emergency relay valve to studs in valve mounting bracket welded to reservoir. Lift off emergency relay valve and re-

move O-ring gasket from its seat in valve mounting bracket.

- (2) *Installation.* Position O-ring gasket in its seat in valve mounting bracket. Position emergency relay valve on studs of valve mounting bracket and secure with three 3/8-inch lockwashers and 3/8-inch hex nuts. Connect four hose assemblies leading to brake air chambers, and emergency and service air lines to elbows in emergency relay valve. Make operating test and leakage tests (b and c above).

61. Air Reservoir

a. *Drainage of Moisture from Air Reservoir.* Open drain cock (fig. 13) on air reservoir. Close cock after draining.

b. *Test and Check for Serviceability.* With air brake system connected (par. 31b(3)), coat drain cock, pipe plugs, connections between emergency relay valve and air reservoir, connector attaching air line to air reservoir, and outside of air reservoir (figs. 12 and 13) with soapsuds. No leakage is permissible. Tighten any leaking connection. Inspect for damage or corrosion. Replace reservoir if it leaks or if any damage or corrosion is found that would weaken reservoir.

c. *Semitrailer M270A1* (fig. 13).

Caution: Before attempting to remove components of air lines, release air pressure from system by opening drain cock on air reservoir.

- (1) *Removal.* Disconnect connector of air line leading to emergency relay valve. Remove square-head bolt, lockwasher and hex nut from each clamp which mounts air reservoir to chassis frame longitudinal beam. Remove two cap screws, lockwashers, and hex nuts which secure each lower clamp to chassis frame longitudinal beam. Remove clamps and reservoir.
- (2) *Installation.* Position air reservoir, drain cock down and connection end to rear of semitrailer, against upper clamps secured to chassis frame longitudinal beam. Position two lower clamps under reservoir and against beam and secure with two 38 x 1 cap screws, 3/8-inch lockwashers, and 3/8-inch hex nuts. Lock upper and lower clamps with two 3/8 x 5½ square-head bolts, inserted upward through lower clamp, and two 3/8-inch lockwashers and 3/8-inch hex nuts. Position air line leading to emergency relay valve on air l'eser-

voir and tighten connector. Perform leakage test (b above) .

d. Semitrailers M270 and M269 (fig. 12).

Caution: Before attempting to remove components of air lines, release air pressure from system by opening drain cock on air reservoir.

- (1) *Removal.* Remove emergency relay valve (par. 60e(1)). Remove four hex-head bolts, plain washers, and safety nuts which secure air reservoir to two brackets welded to chassis frame cross members. Lower reservoir and remove two grommets from top of each bracket extending from end of reservoir and two cushioned clips securing hose assemblies to brackets.
- (2) *Installation.* Position air reservoir under two brackets welded to chassis frame cross members. Place two grommets on top of bracket extending from each end of reservoir. Aline grommets, and holes in bracket at each end of reservoir with holes in brackets welded to cross member and insert (downward) four 3/8 x 1 hex-head bolts. Install one 3/8-inch plain washer, one cushioned clip with hose assembly attached, and one 3/8-inch safety nut on each inner 3/8 x 1 hex-head bolt. Install one 3/8-inch safety nut and one 3/8-inch plain washer on each remaining 3/8-inch bolt. Install emergency relay valve (par. 60e(2)). Perform leakage test (b above).

**62. Brake Air Chamber and Hydraulic Master Cylinder
(Semitrailer M270A1)
(fig. 17)**

a. Leakage Tests. With brakes applied fully, coat brake air chamber flanges, connections, and plug with soapsuds to check for leakage. No leakage is permissible. If leakage is found at flanges, tighten flange screws evenly and sufficiently to stop leak. Do not tighten flange screws too tight as it will distort flanges and cause new leakage. If leakage is found at connection or plug, tighten connector and plug. Coat area between brake air chamber body and mounting bracket, and drain hole to check for leakage. If leakage, is found, notify ordnance inaintenance personnel.

b. Test for Proper Brake Air Chamber Push Rod Travel.

- (1) *Purpose.* Excessive brake air chamber push rod travel will result in damage to rubber cup in hydraulic mas-

ter cylinder. Insufficient travel will result in ineffective brakes.

- (2) *Test.* With brakes released, insert a small testing rod through one of two inspection holes in brake air chamber. Mark testing rod at surface of mounting bracket when testing rod contacts push rod in air chamber. Apply brakes and again mark testing rod at surface of mounting bracket with testing rod in contact with push rod. Withdraw testing rod and measure distance between marks. The distance between marks will indicate amount of push rod travel. Brakes should be adjusted to permit a minimum of 1/2-inch travel and a maximum of 7/8-inch travel. Adjust brakes (par. 56b) as necessary.

c. Removal.

- (1) Disconnect air line at elbow in cover of brake air chamber.
- (2) Disconnect flexible hydraulic line leading from hydraulic master cylinder.
- (1) Disconnect nut connecting vent tube assembly to filler cap of hydraulic master cylinder and remove vent tube assembly.
- (4) Remove three cap screws, lockwashers, and hex nuts securing mounting bracket of brake air chamber to chassis frame. Lift off brake air chamber and hydraulic master cylinder as a unit.
- (5) Separate hydraulic master cylinder from brake air chamber and mounting bracket by removing three hex nuts and lockwashers which secure cylinder to bolts welded to bracket and pulling cylinder out of brake air chamber.

d. Installation.

- (1) Assemble hydraulic master cylinder to brake air chamber by inserting boot end of cylinder through brake air chamber mounting bracket and brake air chamber opening until cylinder bears against mounting bracket. Secure cylinder to bracket with three 5/8-inch lockwashers and 5/8-inch hex nuts.
- (2) Position assembled brake air chamber and hydraulic master cylinder with mounting bracket against chassis frame and install three 3/8 x 1 cap screws, 3 8-inch lockwashers, and 3 8-inch hex nuts. Tighten nuts.
- (3) Connect flexible hydraulic line to connection in hydraulic master cylinder.

- (4) Refill hydraulic system (par. 66c).
- (5) Position vent tube assembly over filler cap of hydraulic master cylinder and tighten connecting nut.
- (6) Install air line to elbow in cover of brake air chamber and tighten connector.
- (7) Perform leakage tests (a above).
- (8) Bleed hydraulic brake system (par. 66b).

63. Brake Air Chamber (Semitrailers M270 and M269)

a. Leakage Tests. Refer to paragraph 62a.

b. Operating Tests.

- (1) Apply brakes, and note whether brake air chamber push rods move promptly and without binding.
- (2) Release brakes, and note whether brake air chamber push rods return to released position promptly and without binding.

c. Removal.

- (1) Disconnect flexible air line assembly at brake air chamber.
- (2) Disconnect push rod yoke at slack adjuster by removing cotter pin and clevis pin.
- (3) Remove two hex nuts and lockwashers from mounting bolts beneath brake air chamber and lift chamber off mounting bracket.

d. Installation.

- (1) Position brake air chamber on mounting bracket and install two 5/8-inch lockwashers and 5/8-inch hex nuts on mounting bolts beneath chamber.
- (2) Connect yoke of push rod to slack adjuster with 1/2 x 1 13/64 clevis pin and 1/8 x 7/8 cotter pin.
- (3) Connect flexible hose assembly to brake air chamber.
- (4) Adjust brakes (par. 56c).
- (5) Perform leakage tests (par. 62a).

64. Slack Adjusters (Semitrailers M270 and M269)

a. Operating Tests. Adjust brakes (par. 56c). Apply brakes several times and note movement of brake air chamber push rod and slack adjuster (fig. 18). Push rod should move $\frac{3}{4}$ inch but not over 2 inches, for full application of brakes. Should slack adjuster move without turning brake camshaft, replace slack adjuster.

b. Removal.

- (1) Disconnect slack adjuster from brake air chamber push rod by removing cotter pin and clevis pin.
- (2) Remove snap ring from splined end of brake camshaft extending through slack adjuster. Remove washer and slide off slack adjuster.

c. Installation.

- (1) Coat splined end of brake camshaft with light film of oil and slide slack adjuster into position. A slight rotary motion of slack adjuster as it reaches camshaft splines will allow splines in adjuster to mesh with splines on camshaft. Install washer and snap ring on camshaft.
- (2) Connect slack adjuster to yoke of brake air chamber with 1/2 x 1 13/64 clevis pin and 1/8 x 7/8 cotter pin.
- (3) Adjust brakes (par. 56c).
- (4) Test air brake system (a above).

65. Air and Hydraulic Hose, Tubing, and Fittings, Test and Check

a. With air hose couplings (fig. 10) connected to towing vehicle or other air supply, and brakes applied, coat air lines, couplings, and connections with soapsuds. No leak is permissible.

b. Leakage at couplings is usually caused by worn, damaged, or improperly installed gaskets. Install new gaskets to stop leaks.

c. Tighten air line connectors to stop leakage.

d. Tighten fittings on air lines and air and hydraulic hose. Inspect lines for partial restrictions caused by dents or kinks. Inspect hose for wear, cuts, or breaks. Replace with new piece of tubing or hose or new fitting if damaged or if leak cannot be stopped.

66. Air-Over-Hydraulic Brake System (Semitrailer M270A1)

a. *General.* Hydraulic fluid should be checked when brakes are adjusted or when new brake shoe linings are installed. If the fluid is materially darker in color, as compared to new fluid, watery in consistency, comparatively odorless, or lacks a thin lubricating film when rubbed between the fingers, the hydraulic brake system (fig. 10) should be drained, flushed, and refilled with new fluid.

b. *Manual Bleeding of Hydraulic Brake System.*

- (1) The semitrailer brake system must be connected to

3the brake system of the towing vehicle for manual bleeding operations since the brake pedal must be pressed and released to actuate the system. The master cylinder reservoir must be kept full during bleeding operations or air will enter the system and make rebleeding necessary.

- (2) Clean, bleeder screw (fig. 41) at bottom of brake dust shield enclosure.
- (3) Place one end of a length of rubber tube over the bleeder screw. Submerge the free end of the tube in a bottle or jar partially filled with hydraulic brake fluid.
- (4) Remove vent tube assembly and filler cap from top of reservoir of hydraulic master cylinder (fig. 17). Fill cylinder with hydraulic brake fluid to within $\frac{1}{2}$ inch of top.
- (5) While brake pedal on towing vehicle is being pumped slowly up and down, open bleeder screw by three-quarter turn clockwise. Liquid will be forced through line to expel air which will show in bottle or jar as bubbles in fluid coming out of tube. Repeat operation approximately 10 times.
- (6) Observe flow, keeping tube submerged in fluid. When air bubbles cease and stream is a clean, solid mass, close bleeder screw tightly. Remove tube.
- (7) Repeat operation at each wheel, replenishing the fluid in master cylinder reservoir as necessary.
- (8) Install filler cap and vent tube assembly (fig. 17) in top of master cylinder.

c. *Refilling Hydraulic Brake System.*

- (1) Prior to refilling, the entire hydraulic brake system should be flushed with clean denatured alcohol.

Caution: Use denatured alcohol only, as other cleaning agents will swell and soften rubber parts in the system necessitating replacement of the part.

To flush, remove vent tube assembly (fig. 17) and filler cap from top of hydraulic master cylinder and fill cylinder with denatured alcohol. As in bleeding (h above) open each wheel cylinder bleeder screw in turn and pump brake slowly until the passage of clean fluid indicates a clean system. After flushing, repeat process with clean hydraulic fluid to force all of the flushing agent from the system.

- (2) To refill, remove vent tube assembly and filler cap from master hydraulic cylinder and add hydraulic fluid to a level of $\frac{1}{2}$ to $\frac{3}{8}$ inch below top of cylinder. Install filler cap and vent tube assembly.

67. Air Hose Coupling

Note. The removal and installation of the air hose couplings for the service and emergency air lines are the same.

a. Removal. Unscrew connection nut (fig. 23) at rear of air hose coupling installation and slide nut back on air line. Unscrew nut on front of cross member until pressure has been relieved on internal teeth lockwasher. Unscrew nut on nipple connecting air line to elbow in coupling connection. Withdraw air hose coupling, with connection and elbow attached, from front cross member. Remove nut, lockwasher, and tag from connection. Separate elbow, coupling, and connection.

b. Installation.

- (1) Apply pipe compound to threads at tapered ends of connection. Screw connection into air hose coupling. Screw elbow into connection. Install nut and internal teeth lockwasher on connection. Position tag over opening in front cross member and insert assembled coupling and connection through tag and opening.

Caution: Make certain tags are on proper air lines. The tag marked SERVICE must be on right side coupling. The tag marked EMERGENCY must be on left side coupling.

- (2) Position air line against nipple in elbow and tighten nut. Slide connection nut on line onto coupling connection and tighten nut until it is snug against rear of front cross member. Then tighten nut at front of cross member until coupling is secure.
- (3) Opening in each air hose coupling should be vertical and open to centrally located electrical receptacle in cross member. Cover opening with dummy coupling (figs. 28 and 29) unless connection to air supply is to be made at once.

Section VIII. LANDING GEAR AND SPARE WHEEL AND TIRE CARRIER

68. Landing Gear Removal

a. Removal of Operating Handcrank Assembly and Crank Shaft Extension Bracket Assembly (fig. 46).

- (1) Remove locknut and hex-head bolt which secure oper-

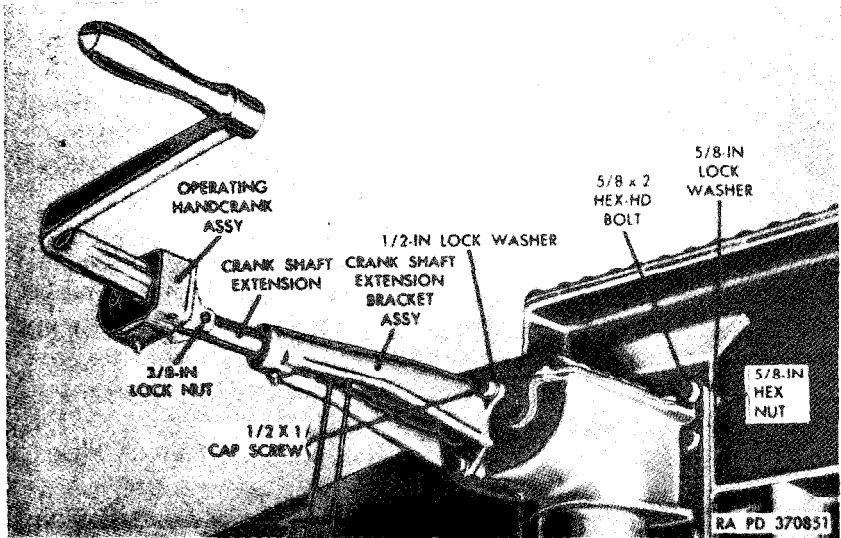

Figure 46. Operating handcrank assembly and crank shaft extension bracket assembly-installed.

sting handcrank assembly to crank shaft extension extending from crank shaft extension bracket assembly. Handcrank assembly will drop off extension.

- (2) Remove three cap screws and lockwashers which secure crank shaft extension bracket assembly to gear box of right leg assembly of landing gear. Slide crank shaft extension bracket assembly outward and remove crank shaft extension bracket assembly and handcrank shaft extension.

b. Removal of Landing Gear Leg Assemblies (fig. 20).

- (1) Lift front end of semitrailer with jacks and block. Block wheels, using chock blocks (fig. 14) to prevent movement of semitrailer.
- (2) If leg assemblies of semitrailer M270A1 are being removed, remove two hex nuts and two lockwashers from each U-bolt assembly which secures lower portion of upper leg to bracket welded to chassis frame and remove U-bolt assembly. If leg assemblies of semitrailer M270 or M269 are being removed, remove two hex nuts, two hex-head bolts, and two lockwashers which secure lower portion of each upper leg to bracket welded to chassis frame.
- (3) Remove two hex-head bolts and locknuts which secure crank shaft coupling to end of crank shaft extending

from gear box of right leg assembly and to crank shaft extension. Remove coupling and crank shaft extension. Remove coupling from extension.

- (4) From a position behind welded brackets which mount gear box end of leg assemblies to chassis frame, remove two hex-head bolts and locknuts which secure connecting shaft to operating screw drive shafts of each leg assembly.
- (5) Remove 8 hex-head bolts, hex nuts, and lockwashers (fig. 46) which secure left leg assembly to bracket welded to chassis frame. Slide leg assembly outward until operating screw drive shaft in gear box is clear of chassis frame and brackets. Remove connecting shaft from chassis frame.
- (6) Remove seven hex-head bolts, hex nuts, and lockwashers (fig. 46) which secure right leg assembly to bracket welded to chassis frame. Slide leg assembly outward until operating screw drive shaft in gear box is clear of chassis frame and bracket. Remove leg assembly.

69. Landing Gear Installation

a. Installation of Landing Gear Leg Assemblies.

- (1) Position right leg assembly by inserting operating screw drive shaft, extending from gear box of leg assembly (fig. 20), through openings in bracket welded to chassis frame. Secure leg assembly to bracket with seven 5/8 x 2 hex-head bolts, 5/8-inch lockwashers, and 5/8-inch hex nuts (fig. 46).
- (2) Install connecting shaft to operating screw drive shaft.
- (3) Position left leg assembly by inserting operating screw drive shaft, extending from gear box of leg assembly, through openings in bracket welded to chassis frame, engaging end of connecting shaft. Secure leg assembly to bracket with eight 5/8 x 2 hex-head bolts, 5/8-inch lockwashers, and 5/8-inch hex nuts.
- (4) Secure connecting shaft to ends of each operating screw drive shaft by alining holes in shafts and installing two 3/8 x 13/4 hex-head bolts and 3/8-inch locknuts.
- (5) Assemble crank shaft coupling to crank shaft extension. Position crank shaft coupling, with extension shaft attached, on end of crank shaft extending from gear box of right leg assembly. Aline holes in shafts and coupling and install two 3/8 x 13/4 hex-head bolts and two 3/8-inch locknuts.

- (6) If leg assemblies of semitrailer M270A1 are being installed, position U-bolt assembly over lower portion of upper leg and through openings in brackets welded to chassis frame. Secure the U-bolt assembly with two 9/16-inch lockwashers and 9/16-inch locknuts. If leg assemblies of semitrailer M270 or, M269 are being installed, position mounting holes of bracket welded to collar at lower portion of upper leg in alignment with holes in bracket welded to chassis frame, then install two 5/8 x 13/4 hex-head bolts, 5/8-inch lockwashers, and 5/8-inch hex nuts.
- (7) Lower front end of semitrailer by removing block and jacks. Remove chock blocks from wheels of semitrailer.

b. Installation of operating Handcrank Assembly and Crank Shaft Extension Bracket Assembly (fig. 46).

- (1) Slip large diameter end of crank shaft extension bracket assembly over crank shaft extension. Allow sufficient clearance between extension and bracket assembly to install handcrank holder on extension. Slip holder on extension, then complete installation of bracket assembly over extension and against gear box. Secure bracket assembly to gear box with three 1/2 x 1 cap screws and 1/2-inch lockwashers.
- (2) Position operating handcrank assembly over end of crank shaft extension extending from crank shaft extension bracket assembly. Aline slots in operating handcrank assembly with holes in extension and install 3/8 x 1 3/4 hex-head bolt and 3/8-inch locknut.

70. Spare Wheel and Tire Carrier

a. Removal. Lower spare wheel and tire to ground (par. 29). Remove four hex nuts, lockwashers, and cap screws attaching main member of spare wheel and tire carrier (fig. 47) to chassis frame right longitudinal beam.

b. Installation. Attach main member of spare wheel and tire carrier to chassis frame right longitudinal beam with four 1/2 x 1 1/2 cap screws, 1 1/2-inch lockwashers, and 1/2-inch hex nuts. Raise spare wheel and tire (par. 29).

c. Replacement of Cable. Remove spare wheel and tire carrier (a above). Release cable (fig. 30) from pickup member by removing hex nuts and plain washers from U-bolts. Draw cable from holes in operating shaft. Make a wire cable, with ferrules to prevent unraveling, from 6 feet of 3/16-inch di-

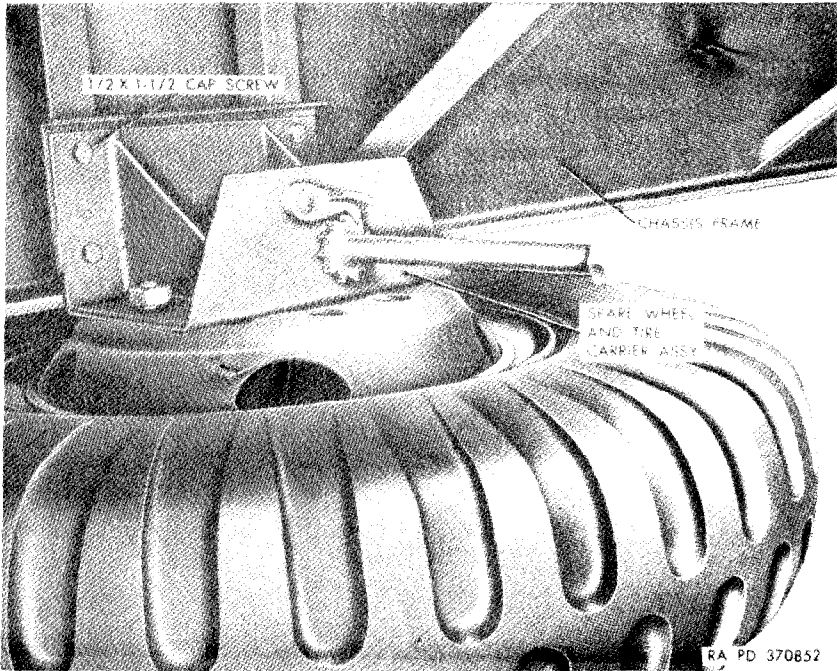

Figure 47. Spare wheel and tire carrier.

imeter, 7 x 19 aircraft-type, preformed cable. Thread through holes in operating shaft until both ends are of equal length. Thread ends through holes in pickup member. Twist ends in loose, single knot across pickup member in such a manner that both ends may be clamped with both U-bolts. Install four ¼-inch plain washers and ¼-inch hex nuts on two U-bolts. Install spare wheel and tire carrier (*b* above).

Section IX. ELECTRICAL SYSTEM

71. Electrical Sockets, Receptacles, and Wiring

a. General. All electrical cables for the lights lead from sockets and/or receptacles mounted on the front cross member of the chassis frame. All cables for taillights, blackout stoplights, and turn indicator lights are attached to the left chassis frame longitudinal beam. Cables for side blackout and side clearance lights lead from the main harness to their respective electrical connectors at the body frame side rails. All cables are secured with cushioned clips which are attached with lockwasher and hex nuts to studs or bolts welded to frame, beams, and cross members. All cables are identified

with circuit number markers which indicate the circuit to which they belong. Male contacts, soldered to ends of cables, are forced through lettered holes in rubber grommet or insert, housed in receptacle. Mating female contacts in plug of intervehicular cable (jumper cable) fit over male contacts when plug is inserted in receptacle. Semitrailers M269 and M270 are provided with 6- and 12-volt socket assemblies (fig. 28) for electrical connection with towing vehicles equipped with 6- or 12-volt systems.

b. Receptacle Contact Connections. Good connections are essential to satisfactory operation of the electrical system. A check must be made to make sure the lamp is in good condition. If any light does not function properly, refer to paragraph 49.

72. Taillights

a. Lamp Replacement. Loosen six screws securing door. Screws are fitted with retaining rings and will remain in door. Remove door and gasket. Push lamp in, turn counterclockwise, and withdraw lamp from socket sleeve. Insert new lamp in socket sleeve and turn clockwise to lock. With intervehicular cable connected, test lamp by turning on switch of

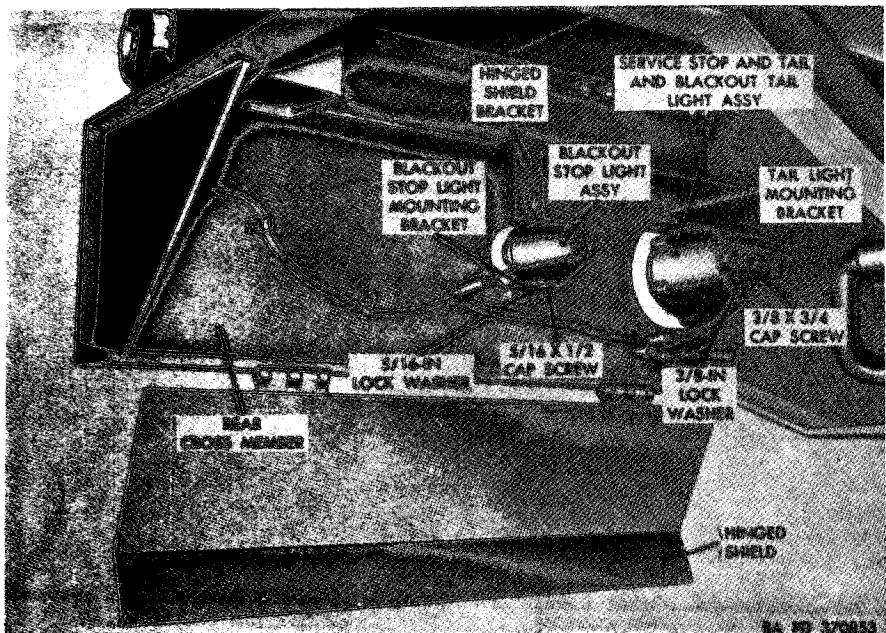

Figure 48. Taillight and blackout stoplight—semitrailer M270A1.

towing vehicle. Position gasket and door to taillight body and tighten six screws.

b. Removal.

(1) *Semitrailer M270A1 (fig. 48).* Remove hex nut, hex-head bolt, and lockwasher securing hinged shield to bracket welded to rear outrigger of body frame. Lower the shield to provide access to taillight. Disconnect taillight cable connectors. Remove two cap screws and lockwashers which secure taillight to taillight mounting bracket welded to longitudinal beam of chassis frame. Remove taillight.

(2) *Semitrailers M270 and M269 (fig. 49).* Remove hex nut, cap screw, and lockwasher securing hinged shield to bracket welded to rear outrigger of body frame. Lower shield. Remove three taillight cable connectors from clips on mounting strap and disconnect connectors. Remove two cap screws and lockwashers which secure taillight to mounting bracket welded to longitudinal beam of chassis frame. Remove taillight,

c. Installation.

(1) *Semitrailers M270 and M269 (fig. 49).* Position taillight behind opening in rear cross member of chassis

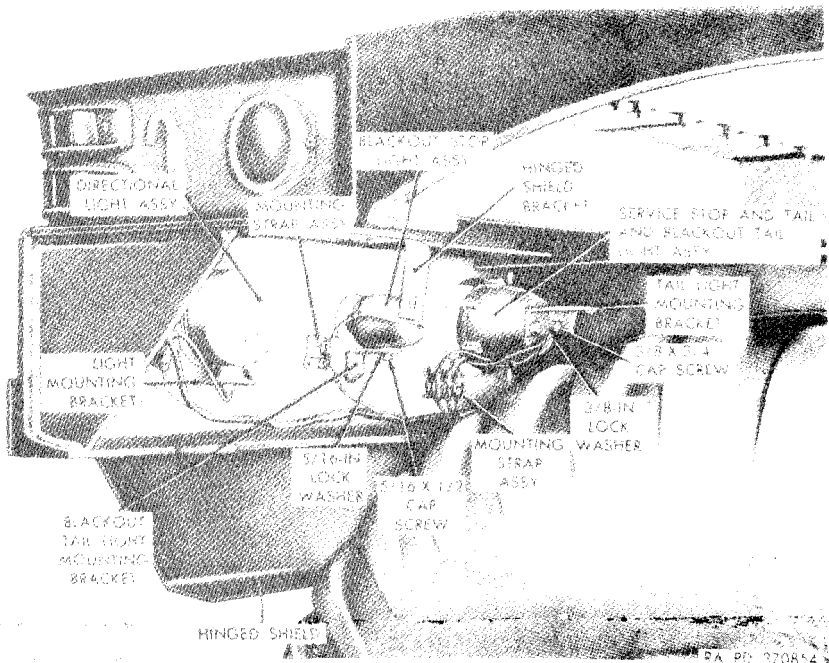

Figure 49. Taillight and directional light—semitrailers M270 and M269.

frame and against taillight mounting bracket welded to longitudinal beam of chassis frame and secure with two 3/8 x 3/4 cap screws and two 3/8-inch lockwashers. Connect three taillight cable connectors. Press connectors into clips on mounting strap. Raise hinged shield to align hole in shield with hole in bracket welded to rear outrigger of body frame. Secure shield with 3/8 x 1 cap screw, 3/8-inch lockwasher, and 3/8-inch hex nut.

- (2) *Semitrailer M270A1*. Position taillight behind opening in rear cross member of chassis frame and against taillight mounting bracket welded to longitudinal beam of chassis frame and secure with two 3/8 x 3/4 cap screws and two 3/8-inch lockwashers. Connect taillight cable connectors. Raise hinged shield to align hole in shield with hole in bracket welded to rear outrigger of body frame. Secure shield with 3/8-inch lockwasher, 3/8 x 1 hex-head bolt, and 3/8-inch hex nut.

73. Clearance Lights

a. Lamp Replacement. Remove two oval-head screws which secure clearance light cover. Lift off cover and lens assembly. To remove lamp, push lamp in, turn counterclockwise, and withdraw. To install lamp, insert lamp in socket, press in, and turn clockwise to lock. Test lamp by turning on light switch in towing vehicle. Position cover and lens assembly, making sure lens is seated on rubber grommet. Attach cover with two 1/4 x 3/4 oval-head screws.

b. Removal. Disconnect cable connector.

Note. On semitrailer M270 M269, remove connector from clip of mounting strap before disconnecting.

Remove clearance light cover (*a* above). Remove four square nuts, lockwashers, and roundhead screws securing light to outer rail of body frame. Remove light and gasket.

c. Installation. If light gasket is damaged, install a new gasket. Insert connecting cable through opening in outer rail of body frame and position clearance light. Secure light to rail with four No. 10 x 2 roundhead screws, No. 10 lockwashers, and No. 10 hex nuts. Install clearance light cover (*a* above). If clearance light is being installed on semitrailer M270 or M269, it will be necessary to press light cable connector into clip of mounting strap.

74. Blackout Stoplight

a. Lamp Replacement. Remove two oval-head screws which

secure door assembly to body of blackout stoplight (fig. 48). Lift off door assembly. To remove lamp, push lamp in, turn counterclockwise, and withdraw. To install lamp, insert lamp in socket, press in, and turn clockwise to lock. Test lamp by turning on light switch in towing vehicle. Position door assembly on body and install two No. 8 x ½ over-head screws.

b. Removal.

- (1) *Semitrailer M270A1* (fig. 48). Remove hex nut, hex-head bolt, and lockwasher securing hinged shield to bracket welded to rear outrigger of body frame. Lower hinged shield. Disconnect light cable connector. Remove cap screw and lockwasher which secure blackout stoplight to mounting bracket welded to rear cross member of chassis frame. Remove light.
- (2) *Semitrailers M270 and M269* (fig. 49). Remove hex nut, cap screw, and lockwasher securing hinged shield to bracket welded to rear outrigger of body frame. Lower shield. Remove light cable connector from clip on mounting strap. Disconnect connector. Remove cap screw and lockwasher which secure blackout stoplight to mounting bracket welded to rear cross member of chassis frame. Remove light.

c. Installation.

- (1) *Semitrailers M270 and M269*. Position blackout stoplight on mounting bracket and secure with 5/16 x 1/2 cap screw and 5/16-inch lockwasher. Connect light cable connector. Press connector into clip on mounting strap. Raise hinged shield to aline hole in shield with hole in bracket welded to rear outrigger of body frame. Secure shield with 3/8 x 1 cap screw, 3/8-inch lockwasher, and 3/8-inch hex nut.
- (2) *Semitrailers M270A1*. Position blackout stoplight behind opening in rear cross member of chassis frame and on blackout stoplight mounting bracket. Secure light to bracket with 5/16 x 1/2 cap screw and 5/16-inch lockwasher. Connect light cable connector. Raise hinged shield to aline hole in shield with hole in bracket welded to rear outrigger of body frame. Secure shield with 3/8 x 1 hex-head bolt, 3/8-inch lockwasher, and 3/8-inch hex nut.

75. Directional Lights (Semitrailers M270 and M269)

a. Lamp Replacement. Remove retaining wire which secures lens and lens gasket on body of directional light (fig. 49).

Remove lens and lens gasket. To remove lamp, turn counter-clockwise, and withdraw. To install lamp, insert lamp in socket, turn clockwise to lock. Test lamp by turning on switch in towing vehicle, Position lens gasket and lens in body of light and secure with retaining wire.

b. Removal. Remove hex nut, cap screw, and lockwasher securing hinged shield to bracket welded to rear outrigger of body frame. Lower shield. Remove light cable connector from clip on mounting strap. Disconnect connector. Loosen hex nut and internal-teeth lockwasher which secure directional light (fig. 49) to light mounting bracket welded to rear cross member of chassis frame. Slip light out of slot in bracket.

c. Installation. Position directional light in slot of light mounting bracket. Aline lens face of light with opening in rear cross member of chassis frame and tighten 7/16-inch hex nut and 7/16-inch internal-teeth lockwasher. Connect light cable connector. Press connector into clip on mounting strap. Raise hinged shield to aline hole in shield with hole in bracket welded to rear outrigger of body frame. Secure shield with 3/8 x 1 cap screw, 3/8-inch lockwasher, and 3/8-inch hex nut.

Section X. FRAME, BODY, AND EQUIPMENT

76. General

Chassis frame, body frame, and parts are joined by welds and rivets to become one integral unit. Individual parts of body may be removed and installed without complete disassembly.

77. Frame, Body, and Equipment

a. Stakes. Stakes are lifted from stake pockets along side rails of body frame and stowed with line assemblies in stowage box (fig. 21) (M270A1) or stowage compartment (fig. 22) (M270 and M269). Two overlapping U-shaped stake shoes are secured to bottom of stake with eight drive screws. Two chain loops, used to secure line assemblies between stakes, are attached to top of stake with two 1/4 x 5 1/16 roundhead screws, 1/4-inch bolt size lockwashers, and 1/4-inch square nuts.

b. Deck Planks. Deck planks are laid on body frame cross members and secured by molded steel wear strips anchored to the cross members with 5/16 x 2 1/2 carriage bolts, 5/16-inch lockwashers, and 5/16-inch hex nuts. There is a 3/8-inch space between all boards through which bolts pass. In

replacement of planks, splices must be made over body frame cross members.

c. *Stowage Box (Semitrailer M270A1)*. Stowage box (fig. .21) is bolted at the top to side rail of body frame with nine 1/2 x 13/4 cap screws, 1/2-inch lockwashers, 17/32-inch ID plain washers, 1/2-inch hex nuts, and at the rear to right longitudinal beam of chassis frame with six 1/2 x 11/4 cap screws, 1/2-inch lockwashers, 17/32-inch ID plain washers, and 1/2-inch hex nuts. Each stowage box door is opened by pivoting latch handles out of recesses in door and turning clockwise one-quarter turn, then pulling door outward and upward. Hooks, welded to doors, are inserted in slots in body frame side rails to secure doors in open position. Each hinged door is secured to stowage box with eight 3/8 x 1 cap screws, 3/8-inch lockwashers, and 3/8-inch hex nuts.

d. *Stowage Compartment (Semitrailers M270 and M269)*. Plates, angles, and brackets, welded to top surface of front end (nose) of semitrailer, form body of stowage compartment (fig. 22). Hinged doors of compartment are opened by pivoting latch handles out of recesses in doors and turning clockwise one-quarter turn, then pulling doors outward. Doors are secured to compartment with sixteen 1/4 x 3/8 roundhead screws, 1/4-inch bolt size lockwashers, and 1/4-inch square nuts.

CHAPTER 4

FIELD AND DEPOT MAINTENANCE INSTRUCTIONS

Section 1. PARTS, SPECIAL TOOLS, AND EQUIPMENT FOR FIELD AND DEPOT MAINTENANCE

78. General

Tools and equipment and maintenance parts over and above those available to the using organization are supplied to ordnance field maintenance units and depot shops for maintaining, repairing, and/or rebuilding the material.

79. Parts

Maintenance parts are listed in the ORD 8 portion of the Department of the Army Supply Manual ORD 7-8 SNL G-802 which is the authority for requisitioning. Parts not listed in the ORD 8 portion of the ORD 7-8 manual, but required by depot shops in rebuild operations, may be requisitioned from the listing in the corresponding ORD 9 manual and will be supplied if available. Requisitions for ORD 9 parts will contain a complete justification of requirements.

80. Common Tools and Equipment

Standard and commonly used tools and equipment having general application to this materiel are listed in ORD 6 SNL J-8, Section 13; ORD 6 SNL J-9, Sections 2 and 10; ORD 6 SNL J-10, Section 4; and are authorized for issue by tables of allowances and tables of organization and equipment.

81. Special Tools and Equipment

The special tools and equipment in table IV are listed in Department of the Army Supply Manual ORD 6 SNL J-16, Section 64. This tabulation contains only those special tools and equipment necessary to perform the operations described in this manual, is included for information only, and is not to be used as a basis for requisitions.

Section II. REPAIR AND REBUILD OF WHEELS, HUBS, AND BRAKE DRUMS

82. wheels

a. *Disassembly.* Remove wheel from hub (par. 52b). Remove tire from wheel (par. 52c).

Table IV. Special Tools and Equipment for Field and Depot Maintenance

Item	Identifying No.	References		Use
		Fig.	Par.	
REMOVER and REPLACER, bushing assembly in torque rod	7950122 (41-R-2376-580)	50, 58	88c	Removing and installing ball and bushing assembly in torque rod.
REPLACER, oil seal wiper, tube, 5 in. OD, 4.763 in. ID, 11 1/8 in. lg w/ 1/2-in. thk, 4 3/4 in. diam. plug.	7950136 (41-R-2395-560)	50, 55	85e, 89c	Replacing oil seal wiper on axles and trunnion cross tube.

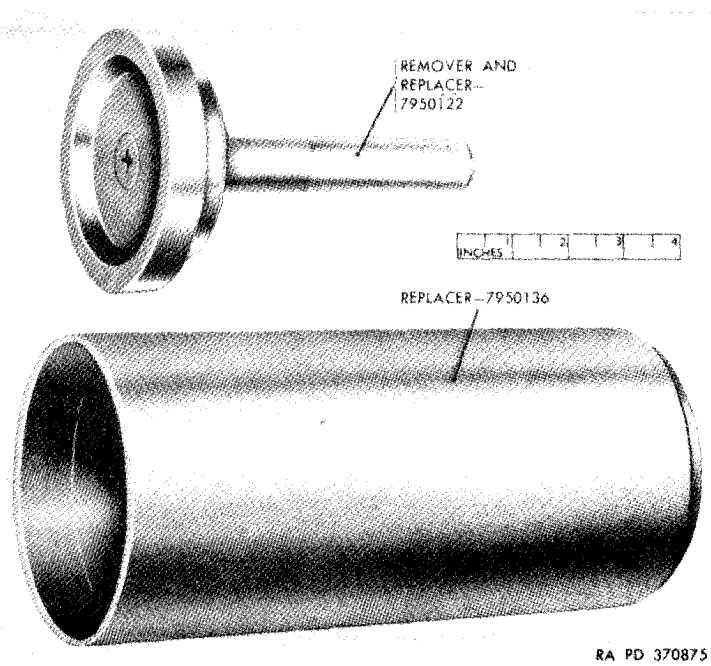

Figure 50. Special tools for field and depot maintenance.

b. *Cleaning.* Wash wheel thoroughly with water under pressure, or water and sponge. Dry with compressed air.

c. *Inspection and Repair.* Inspect wheel carefully for distortion and replace if damaged. Check condition of paint and repaint if chipped or cracked paint or bare metal is found.

Inspect mounting stud holes for apparent wear due to loose mounting and replace wheel if worn. Check split retaining ring for wear or distortion and replace if wear or distortion are such as to prevent ring from holding tire effectively.

d. *Assembly.* Install tire on wheel (par. 52d). Install wheel on hub (par. 52e).

83. Hubs and Brake Drums

a. *Disassembly.* Remove hub and brake drum (F or M, fig. 51) from axle (par. 53a). Remove brake drum from hub (par. 53d and f).

b. *Cleaning.* Wash hub and drum assembly and bearings thoroughly with mineral spirits paint thinner or dry-cleaning solvent and allow bearings to dry. Refer to TM 37-265 for care and maintenance of bearings.

c. *Inspection and Repair.*

Note. The key letters shown in parentheses are in figure 52.

- (1) *Hubs.* Inspect each hub (G) and adapter (C) carefully for cracks and other indications of damage. Replace hub or adapter if damaged. Inspect (bearing) cups (H) for cracks, chipped spots, or wear caused by contact with bearing rollers. Make sure cups fit tightly in hub. If cups are damaged or worn, replace (par. 53h and i). Oil bearing cones and rollers lightly and rotate by hand to test for tightness. Replace if there is evidence of scoring, pitting, or wear. Inspect oil seals to make sure contact material is intact and pliable. Inspect threads on wheel studs (A) in hub and in bearing nuts and wheel cap nuts; replace if threads are stripped. Wheel studs have serrated shanks and are pressed into hub. To drive out, use soft bar and hammer. To replace, mate serrations in bolt with serrations in hole so as not to destroy formations.
- (2) *Brake drums.* Inspect brake drums (J) for warpage, cracks, or scored braking surface. Place drum in lathe and check run-out of braking surface. Run-out must not exceed 0.007-inch total indicator reading. Refinish surface on lathe if scored or if run-out exceeds 0.007 inch. If refinishing requires removal of more than 3/32 inch of metal (3/16 inch on diameter), or if diameter of braking surface is greater than specified repair and rebuild standards (par. 111), replace drum.

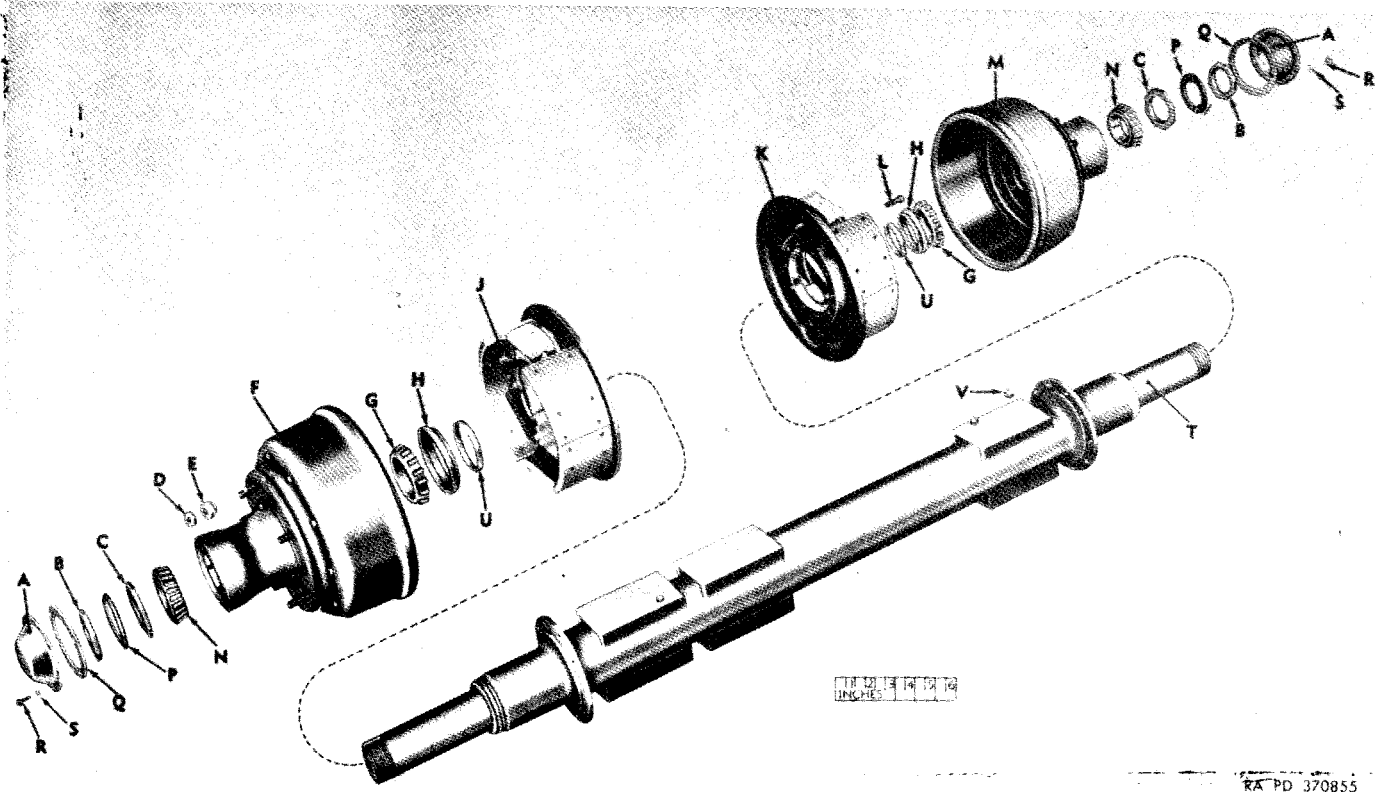

Figure 51. Hubs and brake drums, brakes, axle, and parts—semitrailer M270A1—partial exploded view.

RA PD 370855

A-Hub cap 8710725
B-Wheel bearing jamnut 7979263
C-Wheel bearing adjusting nut 7979308
D-¾-in. cap nut 537810
E-1 1/8-in. wheel nut 537806
F-Left drum w/hub assy 8710721
G-Inner cone and roller bearing assy 712286
H-Oil sead 7979349
J-Left brake assy 8710719
K-Right brake assy 8710720
L-9/16 x 1 1/4 cap screw 123936
M-Right drum w/hub assy 8710722
N-Outer cone and roller bearing assy 705155
P-Nut locking key washer 5139123
Q-Hub cap gasket 8710726
R-5/16 x ½ cap screw 120834
S-5/16-in. lockwasher 120214
T-Axle (welded) 8710737
U-Oil seal wiper 7979266
V-9/16-in. safety nut 503327

Figure 51-Continued.

d. *Assembly.* Install brake drum on hub (par. 53e and g).
Install hub and brake drum (par. 53c).

84. Spring Seat Bearings

a. *Disassembly.* Remove spring seat (par. 55a).

Note. The key letters shown in parentheses are in figure 53.

b. *Cleaning.* Wash spring seat (K) and bearings thoroughly with mineral spirits paint thinner or dry-cleaning solvent. Allow bearings to dry. Refer to TM 37-265 for care and maintenance of bearings.

c. *Inspection and Repair.* Inspect spring seat (K) for cracks or other indications of damage. Replace if damaged. Inspect bearing cups (J) for cracks, chipped spots, or wear caused by contact with bearing rollers. Make sure cups fit tightly in seat. If cups are damaged or worn, replace (par. 53h and i). Oil cone and roller assemblies (H and W) lightly and rotate by hand to test tightness. Replace if there is evidence of scoring, pitting, or wear. Inspect oil seal (Q) make sure contact material is intact and pliable. Inspect threads on spindle of tube. If damaged to the extent that nuts may not hold bearings securely, replace tube with bracket assembly (par. 89). Slight irregularities in threads can be corrected with fine file.

d. *Lubrication.* Refer to lubrication order (fig. 32).

e. *Assembly.* Refer to paragraph 55e.

Section III. REBUILD OF AXLES, SPRINGS, AND TUBE, WITH BRACKETS, ASSEMBLY

85. Axle

a. *General.* Generally, axle assemblies will not be removed

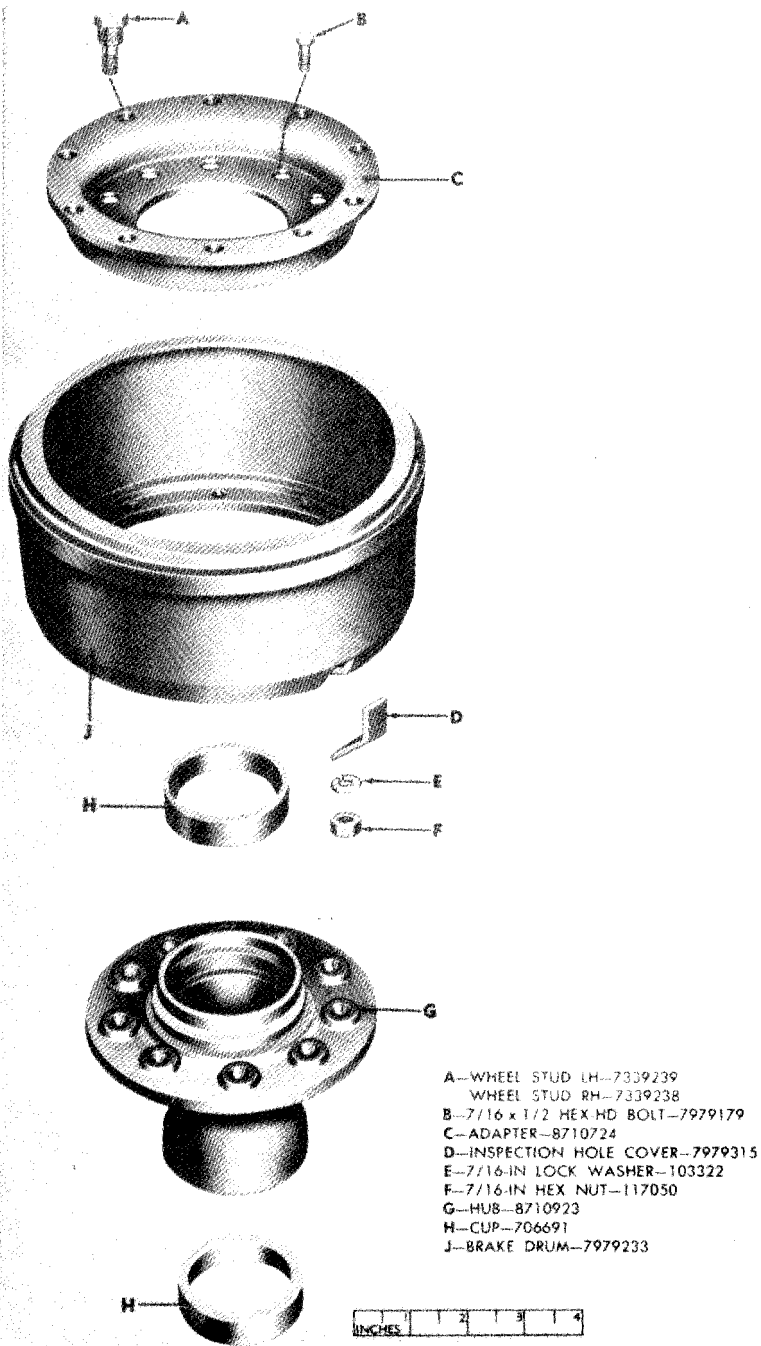

RA PD 370856

Figure 52. Hub, brake drum, adapter, and parts-semitrailer M270A1- exploded view.

unless inspection discloses need for repair or replacement. For inspection purposes, remove wheels, hubs, and brake drums as units (par. 53a).

b. Removal.

(1) *Semitrailer M270A1.*

(a) Position semitrailer on level surface with front end resting on landing gear. Jack up axle to be removed high enough for removal of wheels with hydraulic dolly. Lift rear of semitrailer with hoisting equipment or floor jacks under 'cross tube bracket until weight of springs has been taken off axle. Block frame securely.

Warning: weight of semitrailer must be supported by blocking or support stands placed under rear corners of frame throughout operation.

(b) Remove wheels and hubs from axle to be removed (par. 52b).

(c) Disconnect hydraulic lines at fittings in wheel cylinders of brake assemblies.

(d) Disconnect flexible hydraulic hose at hydraulic master cylinder and at hydraulic lines tee (fig. 41) mounted on rear of axle.

(e) Disconnect two hydraulic lines at hydraulic line tee. Remove four cap screws, lockwasher, and clips that secure hydraulic lines to axle. Remove lines.

(f) Disconnect torque rods (par. 88a) from axle to be removed.

(g) Move axle on hydraulic dolly to free spring from spring guide brackets (C, fig. 57) and then out from under semitrailer.

(2) *Semitrailers M270 and M269.*

(a) Follow procedures described in (1) (a) and (b)

(b) Disconnect flexible air lines at brake air chambers (fig. 18) .

(c) Follow removal procedures described in (1) (g) above.

c. Disassembly.

(1) *Semitrailer M270A1.*

(a) Remove cap screw and lockwasher which secure hydraulic line tee (fig. 41) to axle and remove tee.

(b) Remove spring bearing plates (par. 87a(2)).

(c) Remove brake assemblies (par. 58b).

A-5/16x cap screw 120834
 B-5/16in. lockwasher 120214
 C-Seat cap 7979306
 D-Cap gasket 7979274
 E-Bearing Jamnut 7979263
 F-Key washer 7535270
 G-Bearing adjusting nut 7979308
 H-outer cone and roller bearing assy 703155
 J- Bearing cup 706691
 K-Spring seat 7979305
 L-Spring saddle 7979316
 M-U-Bolt 7979365
 N-1¼-in. lockwasher 131050
 P-1¼ x 5 5/8 hex-hd bolt 7979325
 Q-Oil seal 7979349
 R-Oil seal wiper 7979266
 S-Felt seal retainer 7979246
 T-Felt seal 7979267
 U-Seal retaining washer 7979265
 V-Tube plug 7979268
 W-Inner cone and roller beaving assy 712286
 X-Pipe plug 103883
 Y-1-in. lockwasher 131144
 Z-1-in. hex nut 7979366

Figure 53-Continued.

axles and wheel retaining parts with mineral spirits paint thinner or dry-cleaning solvent.

e. Inspection and Repair. Inspect for broken or cracked spring bearing plates, spring guide brackets, torque rod brackets, and torque rod bracket mounting brackets. Replace broken or cracked parts. Check bearing seats and oil seal wiper (U, fig. 51) for roughness or damage. File or grind smooth, high spots, burrs, or roughness. Check threads of spindles of axles for wear, crossed threads, or damage. Using fine file, file off burrs or hand chase threads if necessary. Check spindles of axles for bend. Indications of a bent axle spindle are binding bearings, which cannot be adjusted properly, and extremely uneven wear of brake linings. Axle spindles which are bent but not cracked, can be straightened. Use puller to remove oil seal wiper (fig. 54) if damaged. Use replacer 7950136 (fig. 55) to install new Oil seal wiper. Check for damaged paint and repaint where necessary.

f. Assembly.

(1) *Semitrailer M270A1.*

(a) Install brake assemblies (par. 58c).

(b) Install spring bearing plates (par. 87a(3)).

(c) Position hydraulic lines tee (fig. 41) over centrally located tapped hole in axle. Secure tee with one 5/8 x 3/4 cap screw and 5/8-inch lockwasher.

(2) *Semitrailers M270 and M269.*

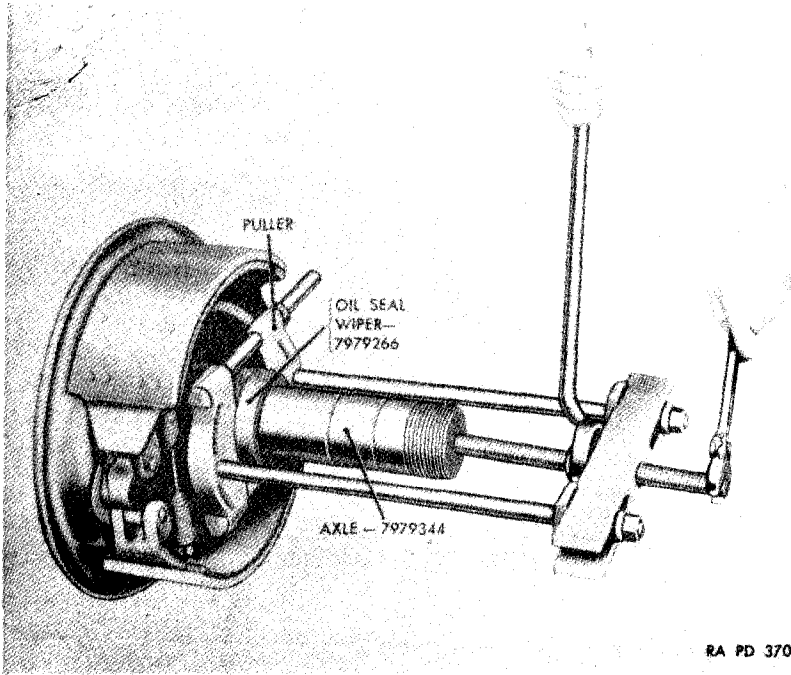

RA PD 370858

Figure 54. Removing oil seal wiper from axle using puller.

- (a) Position each backing plate with assembled shoes and camshaft over axle spindle and against flange. Aligne holes in brake backing plate and flange of axle and install and peen ten 9/18 x 15/8 rivets (E, fig. 59) .
- (b) Install spring bearing plates (par. 87a(3)).
- (c) Install slack adjusters (par. 64c).
- (d) Install brake air chambers (par. 63d).

g. Installation.

(1) *Semitrailer M270A1.*

- (a) Move axle, with hydraulic dolly, into position. Locate with ends of each spring over spring bearing plates (D, fig. 57) in spring guide brackets (C, fig. 57) . Attach torque rods (par. 88d).
- (b) Position hydraulic lines leading to hydraulic lines tee (fig. 41) on axle and connect to tee. Secure lines to axle with four cushioned clips, four No. 10 lockwashers, and four 1/4 x 1/2 cap screws.
- (c) Connect flexible hydraulic hose to tee and hydraulic master cylinder.

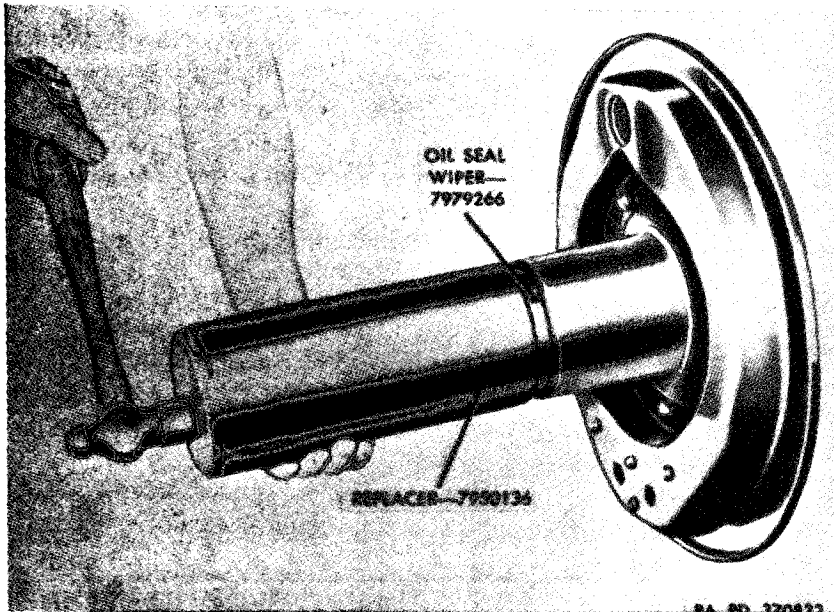

Figure 55. Installing oil seal wiper using replacer 7950136.

- (d) Connect hydraulic lines to fittings in wheel cylinders of brake assemblies.
 - (e) Refill and bleed hydraulic brake system (par. 66b and c).
 - (f) Install wheels and hubs on axle (par. 53c).
 - (g) Lower semitrailer to floor with jacks or other lifting equipment in use.
- (2) *Semitrailer M270 and M269.*
- (a) Follow installation procedures described in (1) (a) above.
 - (b) Connect flexible air lines to brake air chambers (fig. 18).
 - (c) Follow installation procedures described in (1) (f) and (g) above.

86. Springs

a. Removal.

Note. The key letters shown in parentheses are in figure 53, except where otherwise indicated.

- (1) Position semitrailer on level surface with front end resting on landing gear. Jack up rear-rear axle so wheels on both sides can be removed. Jack up forward-rear axle so wheels on side from which spring

is to be removed can be taken off. Place jacks or hydraulic dolly under trunnion cross tube and take up weight. Block up rear corners of body frame with support stands or support by overhead crane.

- (2) Remove wheels (par. 52b).
- (3) Remove flexible air or hydraulic lines from axles and/or brake air chambers.
- (4) Adjust jacks under trunnion cross tube to take weight of spring off axle. Remove four hex nuts (Z) and lockwashers (Y) from two U-bolts (M). Remove (J-bolts and raise and remove spring saddle (L). Loosen two hex-head bolts (P) which clamp spring in spring seat (K) and lift spring from seat. Should spring be seized in seat, jack rear-rear axle higher, to force it out.

Caution: Make sure that force required to free spring from seat does not lift semitrailer off supports under body frame.

- (5) Remove upper torque rod (par. 88a) from rear-rear axle.
- (6) Revolve axle to free ends of spring from spring guide bracket assembly (C, fig. 57).
- (7) Lift spring and withdraw end from spring guide bracket on forward-rear axle.

b. Cleaning. Clean mud and dirt from spring with water and stiff brush. Grease can be removed with mineral spirits paint thinner or dry-cleaning solvent.

c. Inspection and Repair. Inspect leaves and clips for cracks or breaks. Note whether excessive wear is apparent on lower leaf at contact of spring bearing plate (D, fig. 57). Replace worn or defective leaves and clips (d (2) and (5) below). Inspect spring bearing plates and spring guide side plates riveted to inside of spring guide brackets. If worn to extent they will need replacement before next overhaul, replace (par. 87(a)).

d. Disassembly and Assembly of Spring.

Note. The key letters noted in parentheses are in figure 56.

- (1) *General.* Generally, springs will be disassembled into separate leaves only for replacement of broken leaves.
- (2) *Disassembly* Clamp spring in arbor press or vise, or put C-clamp over spring near center bolt (A-17) to hold leaves in place after leaf' clips (A-6 and A-13) and center bolt have been removed. File or grind

off deformed ends of two hex-head bolts (A-12) that secure leaf clip to springs, and end of center bolt. Remove two hex nuts (A-11) from hex-head bolts (A-12) and hex nut (A-19) from center bolt (A-17). Pull hex-head bolts through leaf clips (A-13) and clip spacers (A-20). Use heat to open formed leaf clips. Do not heat clips unnecessarily. Gradually relieve tension on clamp, press, or vise. Separate leaves.

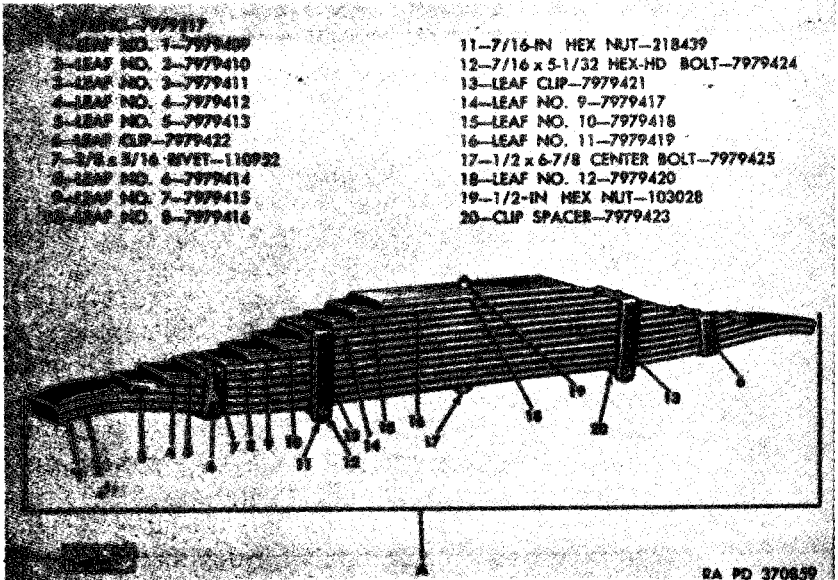

Figure 56. Spring 7979217-assembled view.

- (3) *Cleaning.* Clean each leaf with mineral spirits paint thinner or dry-cleaning solvent. Brush or buff rust and corrosion from leaves.
- (4) *Inspection and repair.* Inspect each leaf for cracks or breaks. Replace defective leaves. Make sure rivets hold clips tightly and check leaf clips for cracks. Cut out and replace any defective 3/8 x 5/16 (button-head) rivets.
- (5) *Assembly.* Assemble leaves in proper order, starting with lower (larger) leaf No. 1 (A-1). Aline holes for center bolt and insert 1/2 x 6 7/8 center bolt (A-17) into hole in leaf No. 1 and through holes in other leaves Nos. 2 through 12. Clamp leaves together with arbor press, vise, or C-clamp, and install 1/2-inch hex

nut (A-19) on center bolt. Tighten nut securely and peen end of bolt. Aline nine leaves and install two clip spacers (A-20) with two 7/16 x 5 1/32 hex-head bolts (A-12) and 7/16-inch hex nuts (A-11). Peen ends of bolts. Heat and bend ends of leaf clips (A-6) into position over four leaves. Clips must be tight enough to hold leaves in alinement without restricting free movement of leaves.

e. Installation.

Note. Key letters shown in parentheses are in figure 53, except when otherwise indicated.

- (1) Lubricate spring bearing plate (D, fig. 57) in accordance with lubrication order (fig. 32). Insert end of spring, with larger leaf down, into spring guide bracket assembly (C, fig. 57) on forward-rear axle. Position spring, with center bolt over recess in spring seat, and press or drive into place, making sure head of center bolt is in recess and spring is seated.
- (2) Position spring saddle (L), making sure center bolt nut fits into recess in saddle and saddle seats on spring. Position U-bolts (M) over saddle and through holes in spring seat (K). Install two 1-inch lockwashers (Y) and two 1-inch hex nuts (Z) on each U-bolt (M), and tighten. Tighten two 1 1/4 x 5 5/8 hex-head bolts (P) which clamp spring in spring seat.
- (3) Revolve rear-rear axle so ends of spring will enter opening in spring guide bracket. Adjustment of jacks under the axle will facilitate this operation.
- (4) Install upper torque rod (par. 88d).
- (5) Install flexible air or hydraulic lines on axle and/or brake air chambers.
- (6) Install wheels (par. 52e) and remove jacks and supports.

87. Spring Bearing Plates and Spring Guide Bracket Side Plates

Note. The key letters shown in parentheses are in figure 57.

a. Spring Bearing Plates.

- (1) *General.* Generally, spring bearing plates (D) will be removed if worn or damaged, at the time of spring removal or axle removal.
- (2) *Removal.* Remove spring (par. 86a) or remove axle (par. 85b). Remove four hex nuts (F) and lockwasher (E) from four hex-head bolts (B) which secure spring

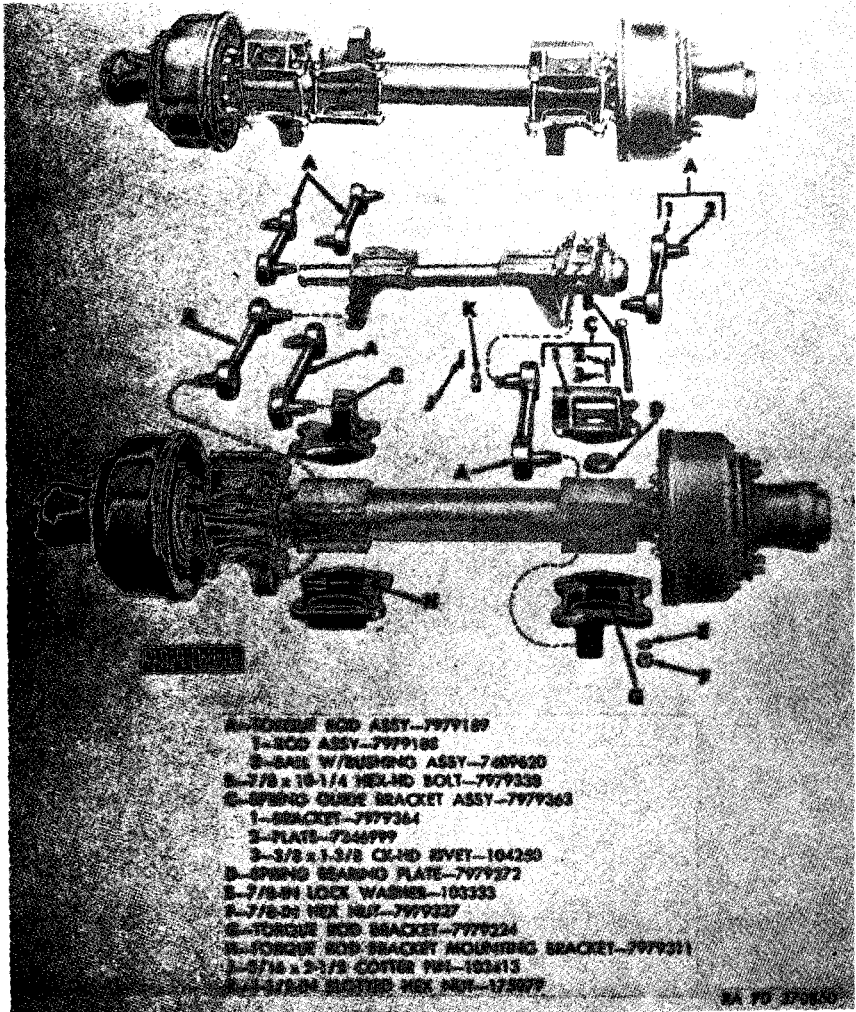

Figure 57. Torque rods, spring guide brackets, and attaching parts-exploded view.

guide bracket assembly (C) and torque rod bracket (G) to axle. Torque rod bracket (G) will drop off axle. Lift spring guide bracket assembly (C) from axle. Remove four hex-head bolts from spring guide bracket. Drive spring bearing plate (D) out of spring guide bracket.

- (3) *Installation.* Press one spring bearing plate (D) into place into spring guide bracket assembly (C). Install four 7/8 x 10 1/4 hex-head bolts (B) in spring guide

bracket assembly. Position spring guide bracket assembly on axle. Rotate the bent hex-head bolts (B) until they hang freely in spring guide bracket without binding against axle. Position torque rod bracket (G) under axle and hex-head bolts (B) protruding from spring guide bracket. Work hex-head bolts through mounting holes in torque rod bracket, taking care not to damage bolt threads. Install a 7/8-inch lockwasher (E) and 7/8-inch hex nut (F) on each bolt and tighten. Install axle (par. 85g) or spring (par. 86e), whichever was removed to facilitate removal of spring bearing plates.

b. Spring Guide Bracket Side Plates.

- (1) *General.* Generally, spring guide bracket side plates (C-2) will be replaced, if worn or damaged, at time of spring or axle removal.
- (2) *Removal.* Remove spring (par. 86a) or remove axle (par. 85 b). Remove spring guide bracket (a (2) above). Drill out two check head rivets (C-3) which secure spring guide bracket side plate to bracket and remove plate.
- (3) *Installation.* Position spring guide bracket side plate (C-2). Install two 3/8 x 1 3/8 check-head rivets (C-3) and peen ends of rivets. Install spring guide bracket (a(3) above) on axle. Install axle (par. 85g) or spring (par. 86e), whichever was removed to facilitate removal of spring guide bracket side plate.

88. Torque Rods

Note. The key letters shown in parentheses are in figure 57.

a. Removal.

- (1) Remove cotter pin (J) from threaded portion of torque rod ball (A-2) and remove slotted hex nut (K). Tap threaded end of ball with soft hammer or bar to loosen ball in torque rod bracket (G).
- (2) Use crowbar or cold chisel to pry torque rod (A-1) out of bracket. Balls are mounted in rubber and can be bent out of normal alignment for removal and replacement.

b. Cleaning. Clean with water and soft brush. Inspect for damaged threads.

c. Inspection and Repair.

- (1) Examine rubber for loss of elasticity or breaks in

material. Make certain ball with bushing assembly (A-2) is securely mounted in rod.

- (2) Remove burrs or hand chase damaged threads with fine file. If damage to thread cannot be corrected, if rubber is hard or cracked, or if ball, with bushing, assembly is loose in rod, install new ball, with bushing, assembly. To install new assembly, mount rod in arbor press and with remover and replacer 7950122 (fig. 58), press out ball, with bushing, assembly. Position new ball, with bushing, assembly (A-2) and press into rod with remover and replacer 7950122 (fig. 58).

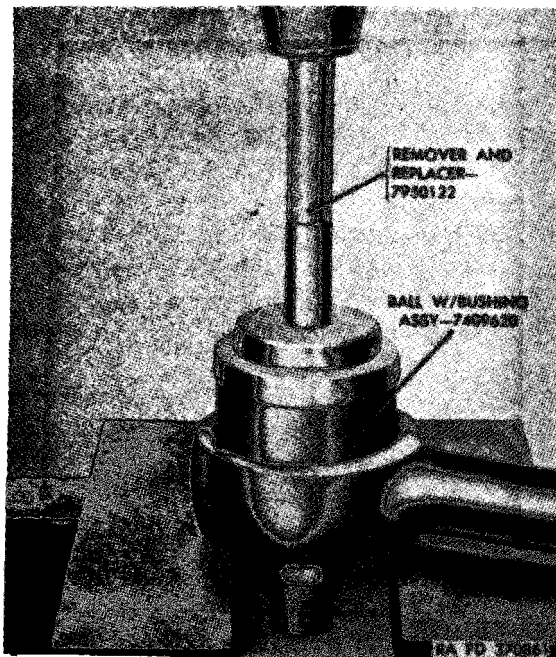

Figure 58. Installing ball, with bushing, in torque rod using remover and replacer 7950122.

d. Installation.

- (1) Insert threaded portion of ball (A-1), at one end of torque rod (A-1), in hole in torque rod bracket (G). Using rod as lever, bend ball out of alignment so threaded portion of ball at other end is close to hole in bracket extending from tube with brackets assembly (fig. 9).
- (2) With crowbar or cold chisel, bend ball out of alignment to enter hole. Use care not to damage threads,

and prevent getting dirt in hole or on ball. Screw on two 1 1/2-inch slotted hex nuts (K), tighten and lock with two 3/16 x 2 1/2 cotter pins (J).

89. Tube, with Brackets, Assembly (Trunnion Cross Tube)

a. Removal.

- (1) Position semitrailer on level surface with front end resting on landing gear.

Warning: Weight of vehicle must be supported by blocking or support stands placed under rear corners of body frame throughout operation.

- (2) Remove wheels (par. 52b).
- (3) Remove torque rods (par. 88a).
- (4) Remove axles (par. 85b).
- (5) Remove springs (par. 86a).
- (6) Remove spring seat (par. 55a).
- (7) Remove eight hex nuts, lockwashers, and hex-head bolts which secure tube with brackets assembly (fig. 41) to brackets riveted to chassis frame. Lift off tube with brackets assembly.

b. Cleaning. Clean mud and dirt from tube and brackets with water and stiff brush. Remove grease from spindles of tube and seat retaining parts with mineral spirits paint thinner or dry-cleaning solvent.

c. Inspection and Repair. Check bearing seats and oil seal wiper for roughness or damage. File or grind smooth, high spots, burs, or roughness. Check threads or spindles of tube for wear, crossed threads, or damage. Using fine file, file off burs, or hand chase threads if necessary. Check tube for bend. Spindles of tube which are bent, but not cracked, can be straightened. Carefully cut badly damaged oil seal wiper with a chisel and remove.

Note. Make sure a new wiper is available before cutting.

Use replacer 7950136 (fig. 55) to drive new wiper into place. Frame bearing surface of both tube brackets must be on same plane. Check with straightedge across both brackets. Check holes in brackets for wear. Should brackets be out of line or holes in bracket worn to extent that bolts do not fit tightly, replace with new tube with brackets assembly.

d. Installation.

- (1) To install tube, with brackets, assembly (fig. 41), which has been removed, position assembly on brackets riveted to chassis frame and install eight 1 1/8 x 3 1/4 hex head bolts, 1 1/8-inch lockwashers, and 11:8 hex nuts.

Note. To install a new tube with brackets assembly, mounting holes in new brackets must be line-reamed in position to 1.125 to 1.128 inches in diameter.

- (2) Install spring seat (par. 55e).
- (3) Install springs (par. 86e).
- (4) Install axles (par. 85g).
- (5) Install torque rods (par. 88d).
- (6) Install wheels (par. 52e).
- (7) Remove blocking, jacks, and lifting equipment, and return semitrailer to level position.

Section IV. REPAIR AND REBUILD OF BRAKES AND BRAKE SYSTEM COMPONENTS

90. Internal Brake Mechanisms

a. Semitrailer M270A1.

- (19 *Removal.* Refer to paragraph 58b.
- (2) *Cleaning,* disassembly, inspection, repair, and assembly. Refer to TM 9-1827C.
- (3) *Installation.* Refer to paragraph 58c.

b. Semitrailers M270 and M269.

Note. The key letters shown in parentheses are in figure 59.

- (1) *Removal.*
 - (a) Remove brake shoes (par. 57a).
 - (b) Remove brake camshaft (par. 57b).
 - (c) If damaged, remove backing plate. Drill out 10 rivets (E) which secure each plate to flange of axle and remove plate from axle.
- (2) *Cleaning.* Clean all parts with mineral spirits paint thinner. Dry thoroughly before inspecting or installing on semitrailer.
- (3) *Inspection and repair.*
 - (a) *Brake shoes and lining.* Check fit of brake shoe (A-3) on anchor pin (L) by shaking shoe by hand. Should excessive wear be apparent replace bushing (A-7) and/or anchor pin (L) and burnish bushing to the tolerance specified in paragraph 111. Check for broken shoe tension spring (G); replace if broken or ineffective. Inspect lining (A-1) for wear. The minimum thickness of lining before relining cannot be specified exactly and is a matter of judgment, depending upon usage and amount of time before next regular inspection. In any case if braking surface is near heads of rivets, lining must be replaced.
 - (b) *Backing plate and needle bearing.* Inspect for bent

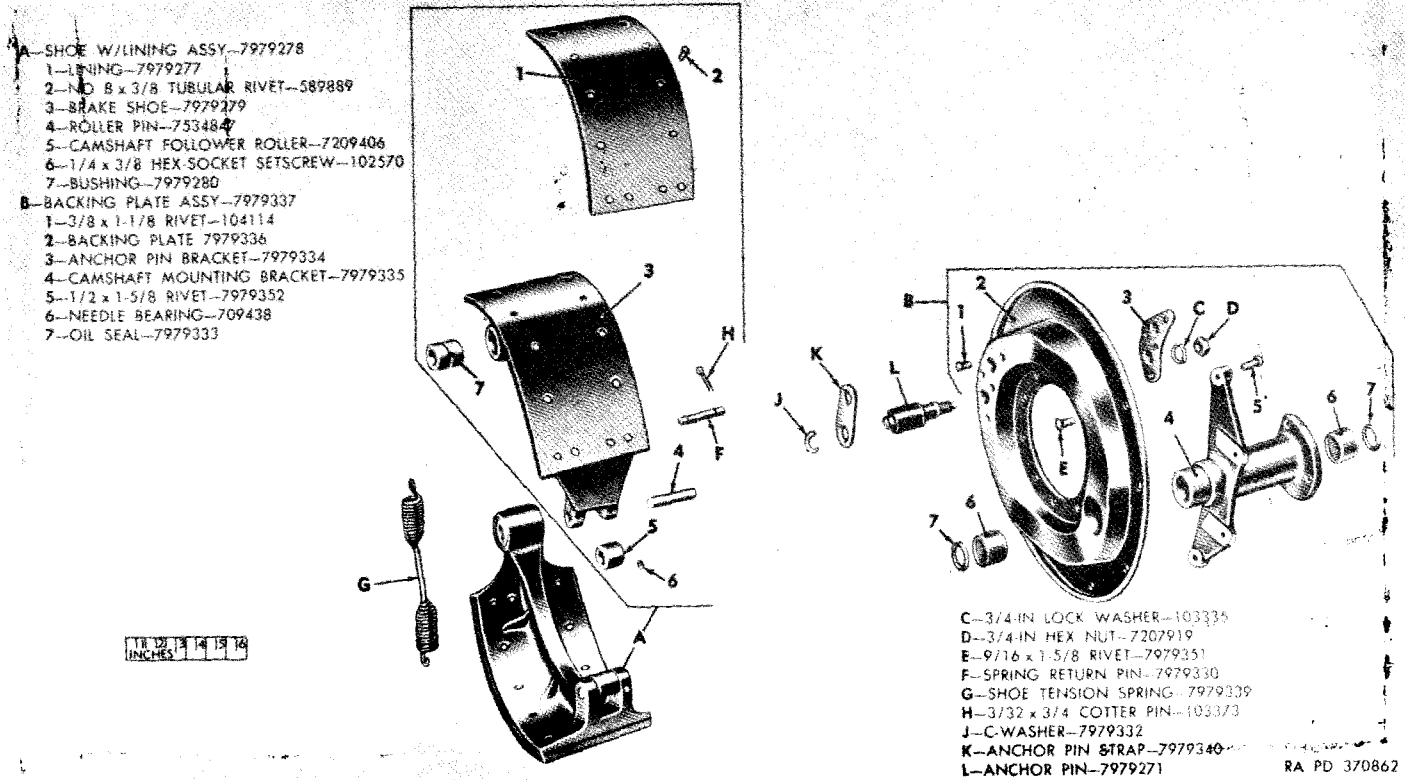

Figure 59. Internal brake mechanism semitrailers M270 and M269—exploded view.

backing plate (B-2). Carefully straighten if bent. Clean and check paint. Repaint if chipped or cracked, or bare metal is found. Inspect needle bearing (B-6) for serviceability. Refer to TM 37-265 for care and maintenance of bearings. Inspect oil seal (B-7) for pliability of packing and general condition. Replace damaged or worn parts.

(4) *Rebuild of brake shoes.*

- (a) *Remove lining.* Remove 16 tubular rivets (A-2) from each lining and strip lining from shoe.
- (b) *Remove anchor pin bushing.* If excessive wear has been found between shoe and anchor pin, drive out bushing (A-7).
- (c) *Remove camshaft follower roller.* Remove setscrew (A-6) securing roller pin (A-4) in shoe. Drive out roller pin and remove camshaft follower roller (A-5).
- (d) *Install camshaft follower roller.* Position camshaft follower roller (A-5) in opening in shoe. Aline holes in shoe and roller and install roller pin (A-4). Secure roller pin in shoe with 1/4 x 3/8 hex socket setscrew (A-6).
- (e) *Install anchor pin bushing.* Using an arbor press, press bushing (A-7) into shoe. Burnish bushing to 1.373-1.374 inside diameter.
- (f) *Install lining.*
 1. Install new lining (A-1) on both brake shoes of one brake mechanism at same time. If brake drums have been machined, shims of thickness of metal removed should be installed under linings.
 2. Aline the end rivet holes in brake shoe (A-3) and lining and clamp lining in place with suitable clamp. Install the end No. 8 x 3/8 tubular rivets (A-2) in lining. Remove clamp and install 15 remaining tubular rivets.
 3. After relining brake shoes, check contact of lining with shoe. An 0.010-inch feeler gage should not enter between shoe and lining at any point. Brake lining should be ground concentric with drum center with suitable grinder after installation on axle.

(5) *Brake camshaft needle bearing.*

- (a) *Removal.* Needle bearings (B-6) are removed with a puller (fig. 60). Tongs of puller must be installed with claws out, so they can be inserted into bore of bearing and expanded under inner end of bearing.

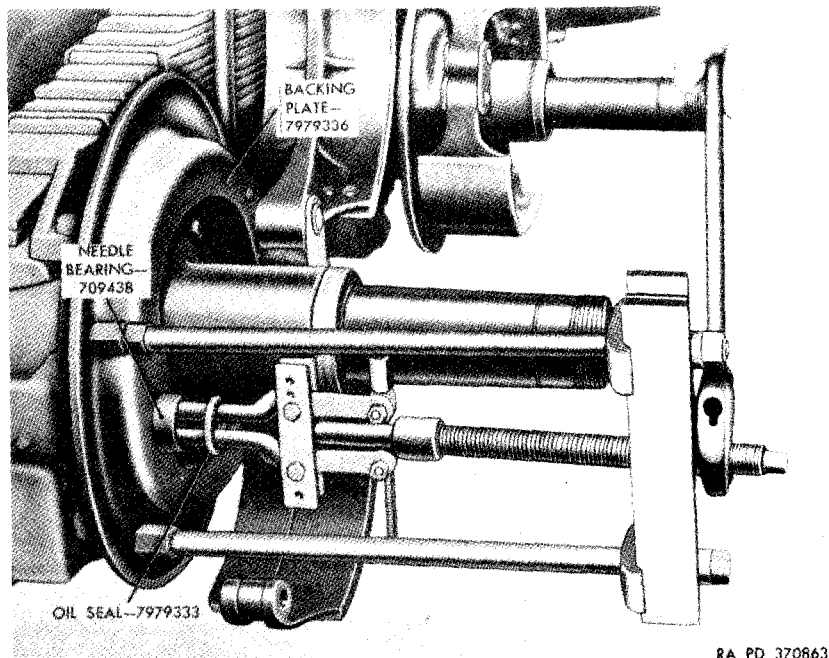

Figure 60. Removing brake camshaft needle bearing using puller—semi-trailers M270 and M269.

Oil seal (B-7) will come out with bearing or can be withdrawn independently with offset screwdriver.

(b) *Installation.*

1. Position needle bearing (B-6) over bearing seat and using an arbor press, press bearing into place. Use block of wood or soft metal over bearing when pressing into place. Do not tap on bearing with hammer. Bearing must be pressed in so that outer end of bearing is flush with seat of oil seal.
2. Press oil seal (B-7) into place using care not to damage. Use block of wood or old oil seal over seal being installed, if force is required to seat. When installed, seal must be flush with face of camshaft mounting bracket (B-4).

(6) *Installation.*

- (a) If backing plate (B-2) was removed due to damage, position new or rebuilt backing plate (B-2) against outer surface of flange of axle. Aline holes in backing plate and flange and install ten 9/16 x 1 5/8 rivets (E).
- (b) Install brake camshaft (par. 57c).

- (c) Apply a coating of GAA grease to bearing surfaces of anchor pins (L) before installing brake shoes. Install brake shoes (par. 57d).

91. Emergency Relay Valve

a. Semitrailer M270A1.

- (1) *Removal.* Refer to paragraph 60d (1).
- (2) *Cleaning,* disassembly, inspection, repair, and assembly. Refer to TM 9-8601.
- (3) *Installation.* Refer to paragraph 60e (2).

b. Semitrailers M270 and M269.

- (1) *Removal.* Refer to paragraph 60e (1).
- (2) *Cleaning,* disassembly, inspection, repair, and assembly. Refer to TM 9-1827A.
- (3) *Installation.* Refer to paragraph 60e (2).

92. Air Reservoir

a. Semitrailer M270A1.

- (1) *Removal.* Refer to paragraph 61b (1).
- (2) *Cleaning,* inspection and repair. Refer to TM 9-1827A.
- (3) *Installation.* Refer to paragraph 61b (2).

b. Semitrailers M270 and M269.

- (1) *Removal.* Refer to paragraph 61c (1).
- (2) *Cleaning,* inspection, and repair. Refer to TM 9-1827A.
- (3) *Installation.* Refer to paragraph 61c (2).

93. Brake Air Chambers

a. Semitrailer M270A1.

- (1) *Removal,* Refer to paragraph 62c.
- (2) *Cleaning,* disassembly, inspection, repair, and assembly. Refer to TM 9-8601.
- (3) *Installation.* Refer to paragraph 61d.

b. Semitrailers M270 and M269.

- (1) *Removal.* Refer to paragraph 63c.
- (2) *Cleaning,* disassembly, inspection, repair, and assembly. Refer to TM 9-1827A.
- (3) *Installation.* Refer to paragraph 63d.

94. Hydraulic Master Cylinder (Semitrailer M270A1)

a. Removal. Refer to paragraph 62c.

b. Cleaning, Disassembly, Inspection, Repair, and Assembly. Refer to TM 9-1827C.

c. Installation. Refer to paragraph 62d.

95. Air Filters

a. *Removal.* Refer to paragraph 58b.

b. *Disassembly, cleaning, Inspection, Repair, and Assembly.* Refer to TM 9-1827C.

c. *Installation.* Refer to paragraph 58c.

96. Check Valve

a. *Removal.* Unscrew check valve (fig. 13) and remove from emergency relay valve.

b. *Disassembly, Cleaning, Inspection, Repair, and Assembly.* Refer to TM 9-8601.

c. *Installation.* Position check valve in threaded opening of emergency relay valve and tighten.

97. Air Lines and Fittings

Air lines and air line fittings are not ordinarily removed except for replacement. Bent, kinked, or damaged lines and fittings must be replaced. Lines must be kept tightly attached and connected. For general information refer to TM 9-1827A. Repair procedures for air line couplings and hose are contained in TM 9-8601.

98. Slack Adjusters (Semitrailers M270 and M269)

a. *Removal.* Refer to paragraph 64b).

b. *Disassembly, Cleaning, Inspection, Repair, Assembly, and Testing.* Refer to TM 9-1827A.

c. *Installation.* Refer to paragraph 64c.

Section V. REBUILD OF LANDING GEAR, STOWAGE BOX, STOWAGE COMPARTMENT, AND TIRE CARRIER

99. Landing Gear

Note. The key letters shown in parentheses are in figure 62, except where otherwise indicated.

a. *Disassembly of Landing Gear Left Leg Assembly.*

- (1) Following removal procedures outlined in paragraph 68b, remove left leg assembly (G, fig. 61).
- (2) Remove two fillister-head screws (A) and lockwashers (B) which secure bevel gear cover (C) and cover gasket (E) to portion of upper leg gear housing. Remove cover and gasket. Discard gasket. Remove lubricating fitting (D) from cover. Rotate bevel gear shaft (AA) to expose two straight pins (Z) which secure input bevel gear (DD) on shaft, and shaft in

gear housing. Using a drift. pin, tap out straight pins (Z). Partially tap shaft out of gear housing and remove stop washer (CC) input bevel gear (DD) and woodruff key (BB) from shaft. Lift input bevel gear off operating screw bevel gear (G). Remove shaft from gear housing.

- (3) Remove locknut (F) which secures operating screw bevel gear (G) on operating screw. Pull operating screw bevel gear (G) from operating screw (GG). Remove key (EE) from keyway in screw. Remove cotter pin (FF) which secures gib plug (W) in boss of collar at bottom of upper leg. Remove gib plug and gib (X).
- (4) Using soft metal round stock and hammer, carefully tap top end of operating screw (GG) until screw clears bore of upper roller bearing (H) in housing and lower leg (N) with assembled parts can be withdrawn from upper leg. Lift upper roller bearing (H) out of bearing cup in gear housing. Remove bearing cup from seat in gear housing. Remove lower roller bearing (K) from operating screw (GG). Unscrew operating screw until its entire length is free of elevator nut (M) in lower leg. Tap out two shoulder pins (L) which secure elevator nut in lower leg. Remove nut from lower leg. Remove two pipe plugs (P) from lower leg. Remove hex-head bolt (S), two plain washers (R), locknut (U), and shoe pin (Q) which retain shoe (T) on lower leg. Shoe will drop off leg. Remove lubrication fittings (V) from upper leg tube collar and gear housing.

b. Cleaning. Wipe all parts clean. Where old lubricant has hardened, clear with mineral spirits paint thinner or dry-cleaning solvent. Clean bearings thoroughly.

c. Inspection and Repair. Inspect all parts for wear, distortion, or cracks. With fine file, hand-chase threads at gear end of operating screw if necessary. Check hex nut retaining drive bevel gear for damage and replace if necessary. Check elevator nut internal threads for damage or wear, if worn, replace elevator nut. Chase out thread if necessary. Check operating screw for bend by rolling on flat surface. Inspect roller bearings for wear and replace if unserviceable. Refer to TM 37-265 for care and maintenance of bearings. Inspect bearing cup for damage or wear. If cup shows signs of wear, replace. Inspect bevel gears and bevel gear shaft and replace if worn or damaged. File off any burrs on operating screw threads. Check that contact surface of gib is smooth. If not,

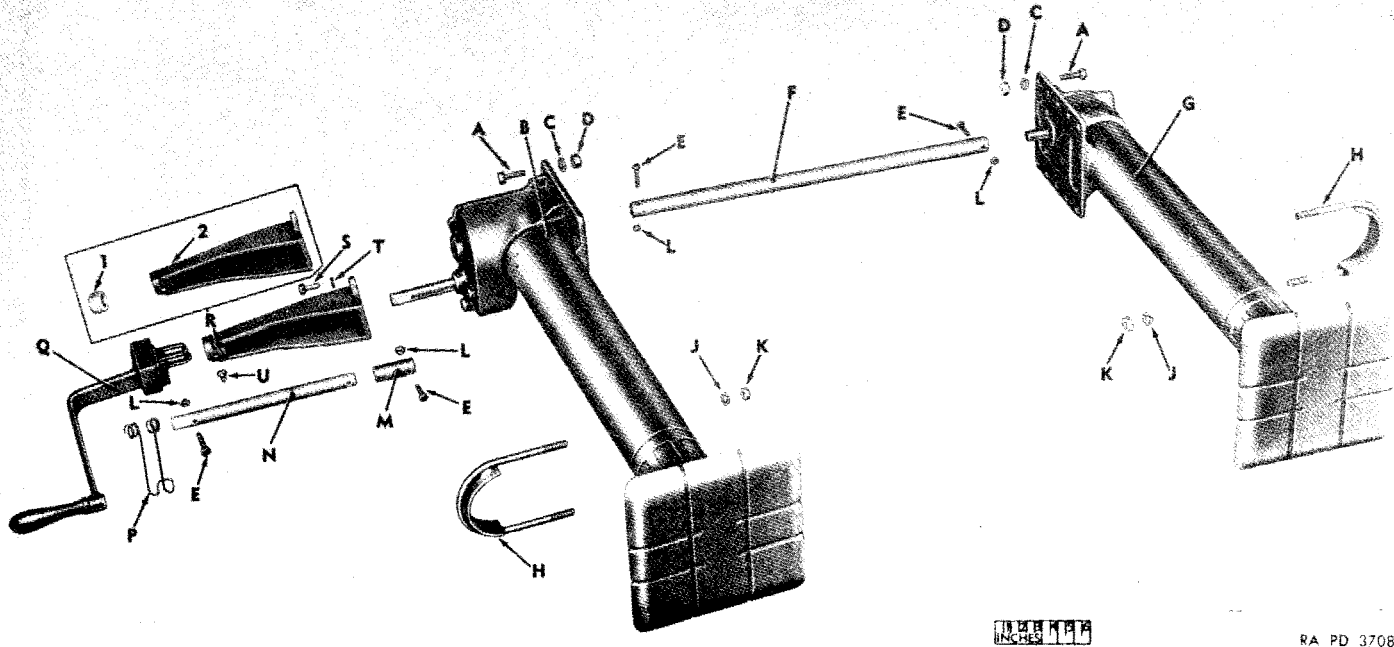

Figure 61. Landing gear—semitrailer M270A1—exploded view.

RA PD 370864

A-5/8 x 2 hex-hd bolt 428691	M-Crankshaft coupling 8380972
B-Right leg assembly 8700958	N-Extension shaft 8380971
C-5/8-in. lockwasher 131059	P-Handcrank holder 8380973
D-5/8-in. hex nut 124589	Q-Operating handcrank assy 8376602
E-3/8 x 13/4 hex-hd bolt 428445	R-Extension bracket assy 8380975
F-Connecting shaft 8380974	1-Bushing 7520707
G-Left leg assy 8700957	2-Extension bracket 8701082
H-U-bolt assy 8730460	S-1/2 x 2 cap screw 122408
J-9/16-in. lockwasher 120898	T-1/2-in. lockwasher 120384
K-9/16-in. hex nut 124634	U-Lubricating fitting 504208
L-1 in. locknut 451009	

Figure 61-Continued.

remove burs with fine file and finish with fine abrasive. Clean and inspect all exterior surfaces for chipped paint. Scrape loose paint to metal and repaint. Check lubrication fittings for serviceability. If bushings (J) show signs of wear, replace.

d. Assembly of Landing Gear Left Leg Assembly.

Note. The key letters noted in parentheses are in figure 62.

- (1) Install lubrication fittings (V) in tube collar and gear housing of upper leg. Position shoe (T) over mounting hole in connector welded to bottom of lower leg (N). Aline holes in shoe with connector mounting hole and install shoe pin (Q). Place a 9/16-inch plain washer (R) on each end of shoe pin (Q) and install ½ x 4½ hex-head bolt (S) through pin. Secure bolt with ½-inch locknut (U). Install two 1/8-inch pipe plugs (P) in tapped holes in cylindrical surface of lower leg. Slide elevator nut (M) into top of lower leg until two openings in sides of nut aline with two openings in sides of lower leg. From a position inside elevator nut, install two shoulder pins (L), smaller diameter ends first, through openings in nut and leg. Screw operating screw (GG) into installed elevator nut until screw is fully installed in lower leg. Press lower roller bearing (K) on operating screw until bearing seats on top surface of elevator nut. Slide lower leg into upper leg, keeping groove in side of lower leg alined with gib mounting hole in collar of upper leg. Install bearing cup of upper roller bearing (H) on seat in housing. Press upper roller bearing (H) on end of operating screw extending into gear housing portion of upper leg to seat in bearing cup.
- (2) Install gib (X) in opening in collar of upper leg to seat in groove in side of lower leg. Secure gib with gib plug (W) and 2 ½-inch cotter pin (FF). Install 0.812 x 0.250 key (EE) in keyway of operating screw.

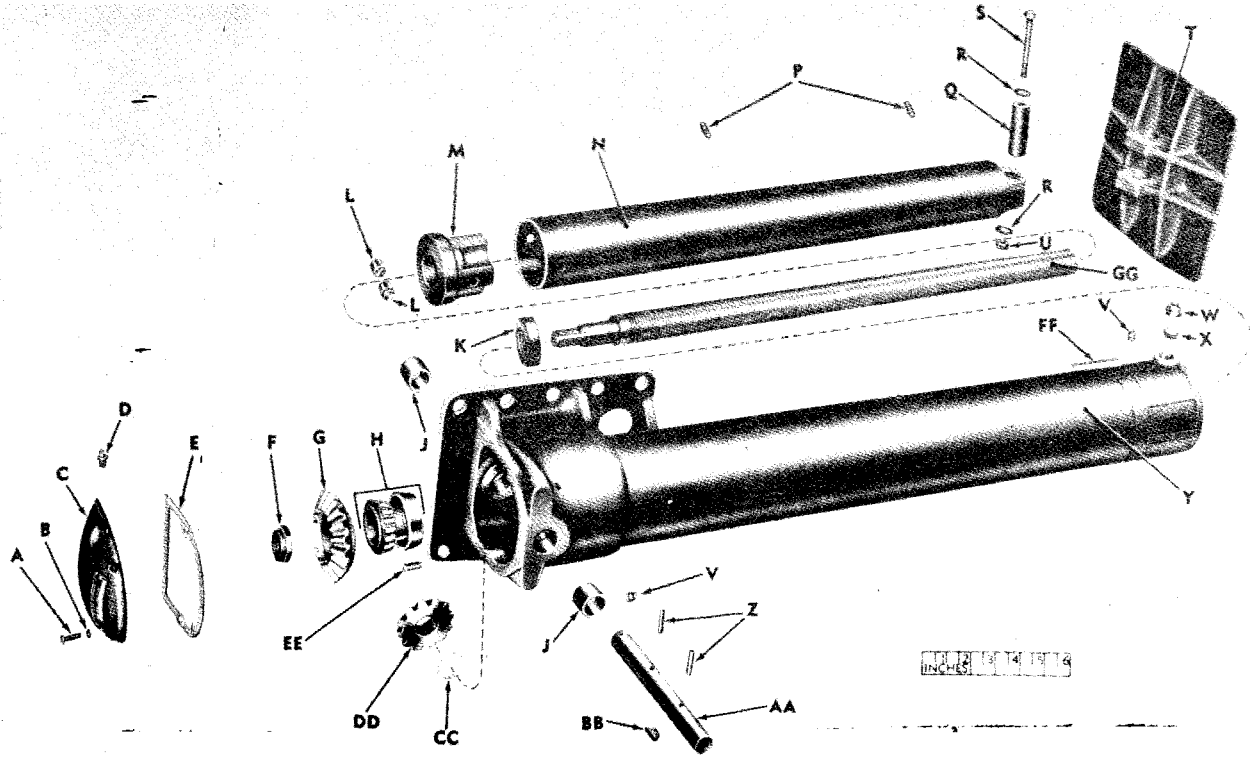

Figure 62. Landing gear left leg assembly 8700957--exploded view.

A-1/4 x 3/4 fillister-hd screw 132266	S-1/2 x 4 1/2 hex-hd bolt 433404
B-1/4-in. bolt size lockwasher 120380	T-Shoe 8376586
C-Bevel gear cover 8379854	U-1/2 x 1/4 hex-hd bolt 433404
D-Lubrication fitting 45-F-465-50	V-Lubrication fitting 504208
E-Cover gasket 8379856	W-Gib plug 8379625
F-1-in. locknut 451091	X-Gib 8376585
G-Operating screw bevel gear 8379855	Y-Upper leg (welded) 8701079
H-Upper roller bearing 703127	Z-1/4 x 1 1/4 straight pin 142521
J-Bushing 8379857	AA-Bevel gear shaft 8376584
K-Lower roller bearing 703032	BB-1/4 x 7/8 woodruff key 124551
L-Shoulder pins 8376596	CC-Stop washer 8376583
M-Elevator nut 8376595	DD-Input bevel gear 8376574
N-Lower leg (welded) 8376597	EE-0.812 x 0.250 key 8376593
P-1/8-in. pipe plug 189566	FF-2 1/2-in. cotter pin 590696
Q-Shoe pin 7365938	GG-Operating screw 8376578
R-9/16-in. plain washer 446230	

Figure 62-Continued.

Install operating screw bevel gear (G), hub first, on shaft making certain installed key seats in operating screw bevel gear keyway. Turn operating screw bevel gear to check that operating screw rotates freely without binding. Secure operating screw bevel gear on operating screw with 1-inch locknut (F).

- (3) Insert bevel gear shaft (AA), keyway end last, through bushing (J) in opening in portion of upper leg gear housing. Before inserting shaft through opposite bushing, install 1/4 x 7/8 woodruff key (BB) in keyway of shaft, then position input bevel gear (DD) in mesh with operating screw bevel gear (G) and align with key installed in shaft. Slip stop washer (CC) on shaft. Slide bevel gear shaft through input bevel gear and bushing (J). Secure input bevel gear and stop washer with 1/4 x 1 1/4 straight pins (Z). Install lubrication fitting (D) in bevel gear cover. Install new cover gasket (E) on upper leg gear housing. Position bevel gear cover (C) on housing and secure with two 1/4 x 3/4 fillister-head screws (A) and 1/4 inch bolt size lockwashers (B). Lubricate left leg assembly in accordance with lubrication order (fig. 32).
- (4) Install landing gear left leg assembly (par. 69).

e. Disassembly of Landing Gear Right Leg Assembly.

Note. The key letters shown in parentheses are in figure 63, except where otherwise indicated.

- (1) Remove landing gear right leg assembly (par. 68).
- (2) Remove lubrication fittings (N, fig. 64) from leg (M, fig. 64). Remove four fillister-head screws (A) and lockwashers (B) which secure bevel gear cover (C)

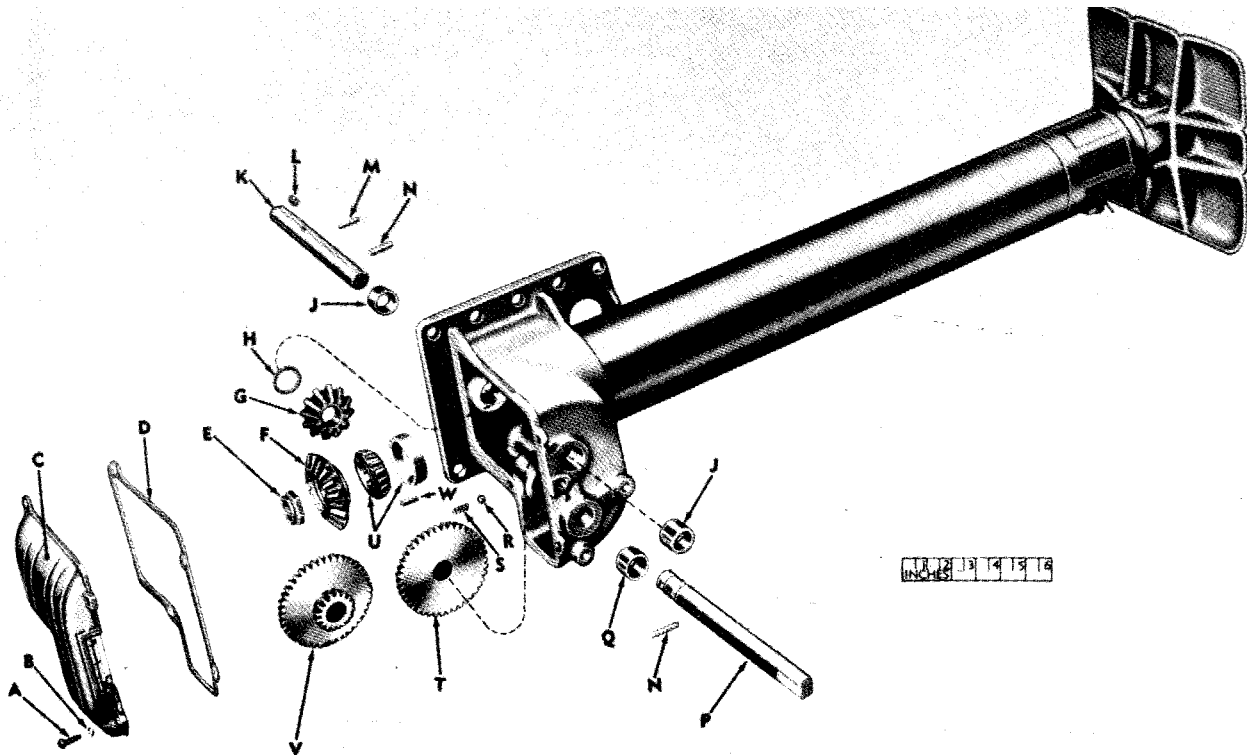

Figure 63. Landing gear right leg assembly—partial exploded view.

RA PD 370RA6

A-1/4 x 3/4 fillister-hd screw 132266
 B-1/4-in. bolt size lockwasher 120380
 C-Revel gear cover 8376588
 D-Cover gasket 8376589
 E-1-in. locknut 451091
 F-Operating screw bevel gear 8379855
 G-Input bevel gear 8376574
 H-Stop washer 8376583
 J-Bushing 8379857
 K-Bevel gear shaft 8376591
 L-1/4 x 7/8 woodruff key 124551
 M-1/4 x 1 1/4 straight pin 142521
 N-3/8 x 1 1/4 straight pin 142543
 P-Crank shaft 8376592
 Q-Bushing 8379857
 R-13/32-in. dia ball 169112
 S-Compression spring 8376590
 T-Bevel gear shaft spur gear 8376610
 U-Upper roller bearing 703127
 V-Crank shaft spur gear 8376611
 W-0.812 x 0.250 key 8376593

Figure 63-Continued.

and cover gasket (D) to upper leg gear housing. Remove cover and gasket. Discard gasket. Remove compression-spring (S) from internal boss in gear housing which mounts end of crank shaft (P). Rotate crank shaft to expose straight pin which secures crank shaft spur gear (V) to crank shaft. Using a drift pin, drive out straight pin (N). Slide crank shaft out of crank shaft spur gear in gear housing. Ball (R) will drop out of internal boss as crank shaft is removed. Lift crank shaft spur gear out of gear housing.

- (3) Rotate bevel gear shaft (K) to expose two straight pins (M and N) which secure bevel gear shaft spur gear (T) to shaft, and shaft in housing. Using a drift pin, drive out straight pins. Partially tap bevel gear shaft from bevel gear shaft spur gear, stop washer (H) and input bevel gear (G). Remove stop washer (H) and input bevel gear (G) from shaft. Remove woodruff key (L) from keyway in shaft. Remove bevel gear shaft spur gear (T) from shaft and remove shaft from housing.
- (4) Remove lock nut (E) which secures operating screw bevel gear (F) on operating screw. Pull operating screw bevel gear from operating screw. Remove key (W) from keyway in screw.
- (5) Remove cotter pin (P, g. 64) which secures gib plug (L, fig. 64) in boss of collar at bottom of upper leg (M, fig. 64). Remove gib plug and gib (K, fig. 64).

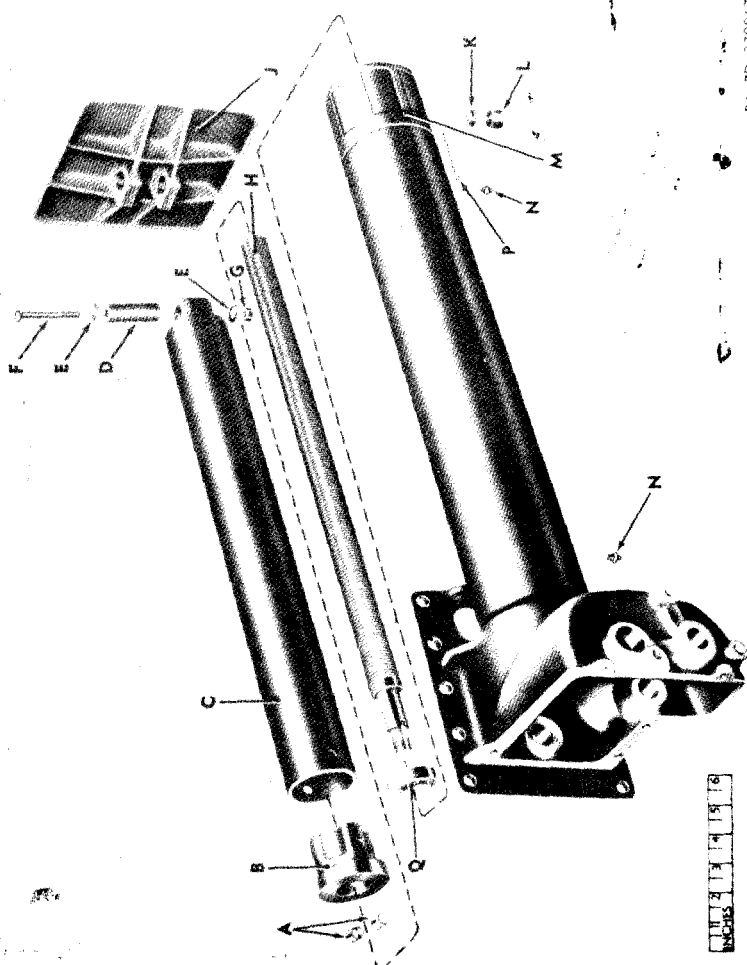

RA PD 370867
 Figure 64. Landing gear right leg assembly—partial exploded view.

- | | |
|----------------------------------|-------------------------------|
| A-Shoulder pin 8376596 | J-Shoe 8376586 |
| B-Elevator nut 8376595 | K-Gib 8376585 |
| C-Lower leg (welded) 8376597 | L-Gib plug 8379625 |
| D-Shoe pin 7365938 | M-Upper leg (welded) 8701081 |
| E-9/16-in. plain washer 446230 | N-Lubrication fitting 504208 |
| F-1/2 x 4 1/2 hex-hd bolt 433404 | P-2 1/2-in. cotter pin 590696 |
| G-1/2 in. locknut 451017 | Q-Lower roller bearing 703032 |
| H-Operating screw 8376578 | |

(6) Using soft metal round stock and hammer, carefully tap top end of operating screw (H, fig. 64) until screw clears bore of upper roller bearing (U) in housing and lower leg (C, fig. 64) with assembled parts can be withdrawn from upper leg (M, fig. 64). Left

upper roller bearing out of bearing cup (U) in housing. Remove bearing cup from seat in housing. Remove lower roller bearing (Q, fig. 64) from operating screw (H, fig. 64). Unscrew operating straw until its entire length is free of elevator nut (B, fig. 64) in lower leg. Tap out two shoulder pins (A, fig. 64) which secure elevator nut in lower leg. Remove nut from lower leg. Remove one hex-head bolt (F, fig. 64), two plain washers (E, fig. 64), one locknut (G, fig. 64), and shoe pin (D, fig. 64) which retain shoe (J, fig. 64) on lower leg. Shoe will drop off leg. Remove lubrication fittings (N, fig. 64) from upper leg tube collar and gear housing.

- f. Cleaning, Inspection, and Repair. Refer to b and c above.*
g. Assembly of Landing Gear Right Leg Assembly.

Note. The key letters shown in parentheses are in figure 63, except, where otherwise indicated.

- (1) install lubrication fittings (N, fig. 64) in gear housing and tube collar of upper leg. Position shoe (J, fig. 64) over mounting hole in connector welded to bottom of lower leg (C, fig. 64). Aline holes in shoe with connector mounting hole and install shoe pin (D, fig. 64). Place one 9/16-inch plain washer (E, fig. 64) on each end of shoe pin (D, fig. 64) and install one $\frac{1}{2}$ x $4\frac{1}{2}$ hex-head bolt (G, fig. 64). Secure bolt with $\frac{1}{2}$ -inch locknut (G, fig. 64). Slide elevator nut (B, fig. 64) into top of lower leg until two openings in sides of nut aline with two openings in sides of lower leg. From a position inside elevator nut, install two shoulder pins (A, fig. 64), smaller diameter end first, through openings in nut and leg. Screw operating screw (H, fig. 64) into installed elevator nut until screw is fully installed in lower leg. Press lower roller bearing (Q, fig. 64) on operating screw until bearing seats on top surface of elevator nut. Install bearing cup of upper roller bearing (U) in seat in housing. Slide lower leg (C, fig. 64) into upper leg (M, fig. 64), keeping groove in side of lower leg alined with gib mounting hole in collar of upper leg. Press upper roller bearing (U) on end of operating screw extending into gear housing portion of upper leg to seat in bearing cup.
- (2) Install gib (K, fig. 64) in opening in collar of upper leg to seat in groove in side of lower leg. Secure

gib with gib plug (L, fig. 64) and 2½-inch cotter pin (P, fig. 64).

- (3) Install 0.812 x 0.250 key (W) in keyway of operating screw. Install operating screw bevel gear (F), hub first, on shaft, making certain installed key seats in operating screw bevel gear keyway. Turn operating screw bevel gear to check that operating screw rotates freely without binding. Secure operating screw bevel gear on operating screw with 1-inch locknut (E).
- (1) Partially insert bevel gear shaft (K), keyway end last, through bushing (J) in opening in bracket side of gear housing portion of upper leg. before inserting shaft through housing and opposite bushing, position stop washer (H) and input bevel gear (G) (pitch to center of housing) in that order, in housing with gear in mesh with operating screw bevel gear (F) and aligned with bore through which shaft is being installed. Slip bevel gear shaft through stop washer and input bevel gear (G) to a position where bevel gear shaft spur gear (T) can be installed on shaft. Install spur gear on shaft. Slide bevel gear shaft through opposite bushing. Aline keyways in input bevel gear and shaft and install ¼ x 7/8 woodruff key (L). Aline holes in bevel gear shaft spur gear and shaft and install 3/8 x 1¼ straight pin (N). Secure input bevel gear on shaft by installing ¼ x 1¼ straight pin (M) in hole in shaft until pin extends an equal distance on both sides of shaft.
- (5) From a position inside of gear housing, place pinion gear end of crank shaft spur gear (V) in mesh with installed bevel gear shaft spur gear (T) and in alignment with housing bore. Slide crank shaft (P) through housing bore, crank shaft spur gear, and internal boss in gear housing. Make certain end of shaft is flush with rear surface of boss. Aline holes in crank shaft spur gear and crank shaft and install 3/8 x 1¼ straight pin (N). Insert 13/32-inch diameter ball (R) and compression spring (S) in hole in top of internal boss. Install a new cover gasket (D) on gear housing. Position bevel gear cover (C) on gear housing and secure with four ¼ x ¾ fillister-head screws (A) and ¼-inch bolt size lockwashers (B). Lubricate right leg assembly in accordance with lubrication order (fig. W).
- (6) Install landing gear right leg assembly (par. 69).

100. Handcrank Assembly (fig. 65)

- a. *Removal.* Refer to paragraph 68a(1).
b. *Disassembly.*

- (1) Remove plug, spring, and ball from handcrank ratchet. Pull pawl lever from pawl pin. Remove three cap screws which secure cover plate to handcrank ratchet and remove cover plate. Remove ratchet and pawl pin with pawl attached from handcrank ratchet. Mark position of pawl on pawl pin and drive pawl pin out of pawl.
- (2) If handcrank handle is damaged, file or grind peened end of binding head rivet and remove rivet and handle from handcrank ratchet.

c. *Cleaning.* Use mineral spirits paint thinner or dry-cleaning solvent to remove grease from parts.

d. *Inspection and Repair.* Inspect handcrank for cracks. If cracks are apparent, replace handcrank ratchet. Replace a broken or worn handcrank handle. Check for a broken or ineffective compression spring and replace if necessary. Ratchet and pawl should be free of nicks and burrs. Remove burrs with a fine file and finish with a fine abrasive. Replace excessively worn parts. Inspect all exterior surface for chipped paint. Scrape loose paint to metal and repaint.

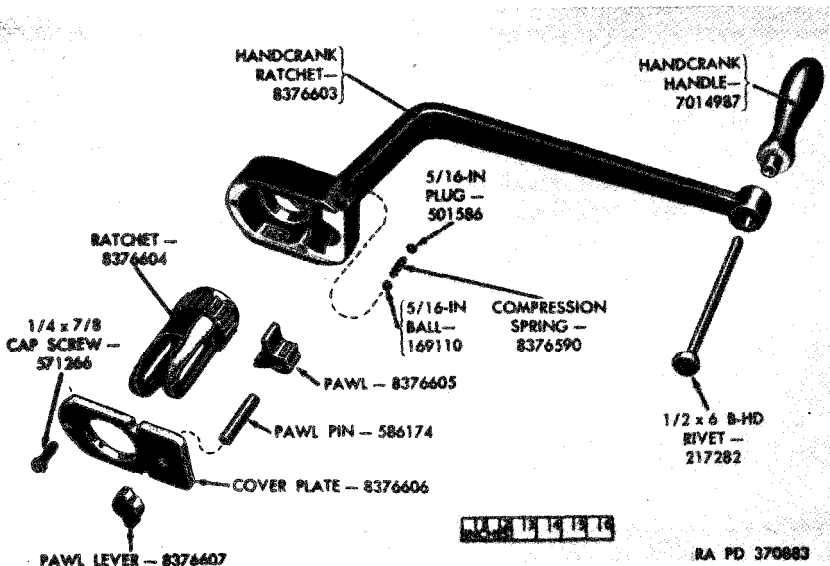

Figure 65. Handcrank assembly 8376602—exploded view.

e. *Assembly.*

- (1) Install ferrule end of handcrank handle in opening in end of handcrank ratchet. Install $\frac{1}{2}$ x 6 binding-head rivet through ratchet and handle. Peen end of rivet over end of handle. Check that handle rotates freely.
- (2) Following marks made at disassembly and using an arbor press, press pawl pin into pawl. Insert pawl pin and pawl into handcrank ratchet making certain pin seats in hole provided in handcrank ratchet. Install ratchet, gear end first, into handcrank ratchet. It may be necessary to rotate the pawl pin slightly to provide clearance for the ratchet. Install cover plate over exposed end of ratchet and against handcrank ratchet. Secure cover plate by installing three $\frac{1}{4}$ x $\frac{7}{8}$ cap screws. Install pawl lever. Install 5/16-inch ball and compression spring in handcrank ratchet and secure with 5/16-inch plug. Lubricate operating handcrank in accordance with lubrication order (fig. 32).

f. *Installation. Refer to paragraph 69b (2).*

101. Stowage Box and Stowage Compartment

a. *Stowage Box (Semitrailer M270A1) (fig. 21).*

(1) *Removal.*

- (a) Support the stowage box and remove nine cap screws, lockwashers, plain washers, and hex nuts which secure front edge of stowage box to side rail of body frame.
 - (b) Remove six cap screws, lockwashers, plain washers, and hex nuts which secure rear of stowage box to right longitudinal beam of chassis frame. Remove stowage box.
- (2) *Disassembly.* Remove eight cap screws, lockwashers, and hex nuts which secure each door to stowage box. Remove door.
- (3) *Cleaning.* Use steam and stiff brush to remove dirt. Use mineral spirits paint thinner or dry-cleaning solvent to remove grease.
- (4) *Inspection and repair.* Inspect stowage box and doors for damage, bare metal, or damaged paint. Straighten bends in metal and if cracked, repair. Refer to TM 9-2852 for welding theory and application. Scrape bare spots or damaged paint to the metal and repaint. Door locks are fitted and spot welded in door openings. Metal

around the lock must be slightly deformed to remove lock but, if done carefully, it can be returned to proper form after installation of lock without damage to door. Inspect for damaged or missing door seals. If damaged or missing, replace.

(5) *Assembly.* Position each door on stowage box and secure with eight 3/8 x 1 cap screws, 3/8-inch locknuts, and 3/8-inch hex nuts.

(6) *Installation.* Position and support stowage box under side rail of body frame and against right longitudinal beam of chassis frame. Secure box to beam with six 1/2 x 1 1/4 cap screws, 1/2-inch lockwashers, 17/32-inch plain washers, and 1/2-inch hex nuts. Secure box to side rail with nine 1/2 x 1 1/4 cap screws, 1/2-inch lockwashers, 17/32-inch plain washers, and 1/2-inch hex nuts.

b. *Stowage Compartment (Semitrailers M270 and M269)* (fig. 22). Each stowage compartment is of welded construction and is welded to the top of the chassis frame at the front end or nose of each vehicle. Each stowage compartment door is removed by removing six round-head screws, lockwashers, and square nuts, which secure door to compartment. To install each door, position door on stowage compartment and secure with six 1/4 x 3/8 a round-head screws, No. 10 lockwashers, and 1/4-inch square nuts. For cleaning, inspection, and repair procedures, refer to a(3) and (4) above.

102. Spare Wheel and Tire Carrier

Note. The key letters shown in parentheses are in figure 66.

a. *Removal.* Refer to paragraph 70a.

b. *Disassembly.* Remove two safety nuts (G) and two wheel securing studs (J) from pickup member (H). Remove two hex nuts (M) and two lockwashers (L) from each U-bolt (K) which secures rope assembly (E) to pickup member (H). Remove U-bolts and rope assembly from pickup member. Draw rope assembly (E) from hole in operating shaft (A). Remove cotter pin (B) from operating shaft and remove operating shaft from main member (F). Drill out rivet (C) which secures shaft pawl (D) to main member (F) and remove shaft pawl.

c. *Cleaning.* Use steam or water with a stiff brush to remove dirt. Use mineral spirits paint thinner or dry-cleaning solvent to remove grease.

d. *Inspection and Repair.* Inspect for frayed cable (E-1) and loose U-bolts (K). Check main member (F) for bend or

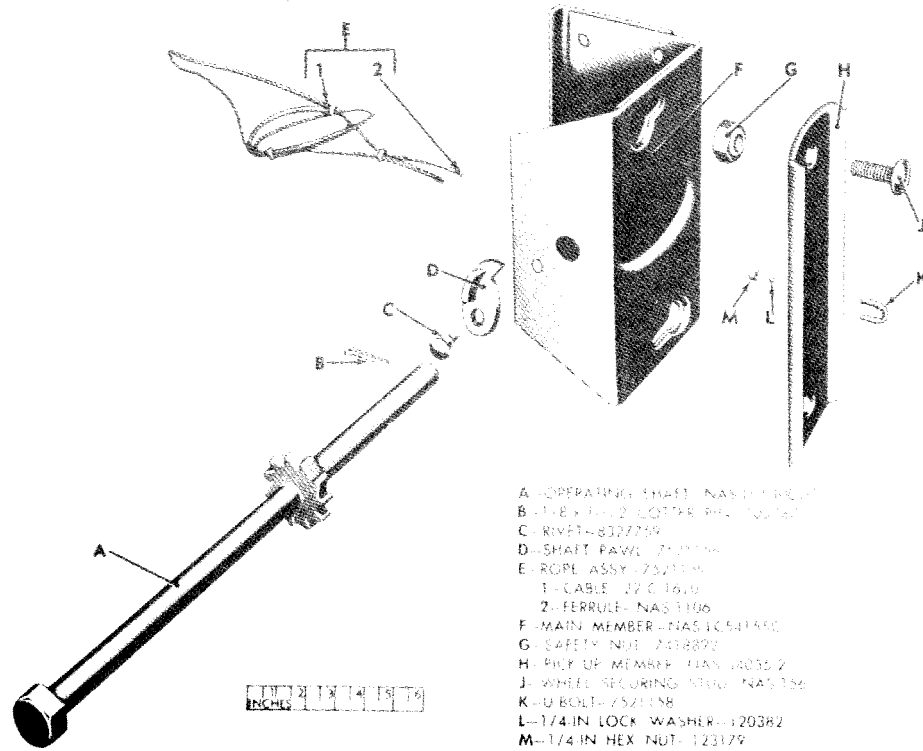

RA PD 370868

Figure 66. Spare wheel and tire carrier—exploded view.

cracks and for damaged paint. Check operating shaft (A) for straightness and make sure shaft pawl (D) swings freely on its mounting rivet (C). Check threads on bolts and nuts of pickup member. Replace cable (par. 70c) if any broken strands are apparent. Tighten U-bolts if loose or cable has been replaced. Main member can be reshaped if bent but should be replaced if it cannot be returned to free working condition. If ratchet on operating shaft is broken or damaged, replace operating shaft. If shaft pawl does not swing freely, replace (see below) pawl. Replace bolts or nuts which have seriously damaged threads.

e. *Assembly.* Position shaft pawl (D) on main member (F) and secure with rivet (C). Insert operating shaft through main member (F) and secure with 1/8 x 1½ cotter pin (B). Install cable (par. 70c) of rope assembly (E) in operating shaft (A). Position ferrule end of rope assembly (E) on pickup member (H) and install two U-bolts (R) over cable of rope assembly (E). Secure each U-bolt with two ¼-inch lockwashers and two ¼-inch hex nuts. Wind rope assembly (E) into operating shaft (A). Install two wheel securing studs (J) and two safety nuts (G) on pickup member (H).

f. *Installation.* Refer to paragraph 70b.

103. Chock Blocks

(fig. 14)

a. *Disassembly.* File or grind off deformed threads at end of four carriage bolts which secure laminae of block and remove four plain nuts from bolts. Withdraw bolts from laminae. If bolts turn in block while unscrewing nuts, force screwdriver or chisel between laminae to bind and hold bolts.

b. *Cleaning.* Use water and stiff brush to remove dirt. Use mineral spirits paint thinner or dry-cleaning solvent to remove grease.

c. *Inspection and Repair.* Inspect attachment of chain to frame to make sure it is secure and that snap is free to turn on screw. Check chain for damage which may result in break. Check block for serviceability. Tighten attachment to frame if loose and adjust if necessary, to allow snap to turn freely. Replace damaged link in chain with chain repair link. Repaint any part which may be bare or on which paint is damaged.

d. *Assembly.* Assemble laminae and secure with four carriage bolts and four 5/16-inch plain nuts. Peen bolt ends over nuts. If old bolts are too short to allow peening of bolt end after nut is installed, replace with new bolts.

Section VI. REBUILD OF ELECTRICAL SYSTEM

104. Receptacle, Wiring Cable, Terminals, and Connectors

Receptacle pins, receptacle sockets, and terminals are always soldered to ends of wires or cables. All are replaced in essentially the same manner. Refer to TM 9-1825E for disassembly, inspection, repair, and assembly procedures for receptacle and plug-type connectors.

105. Taillights, Blackout Stoplights, Directional Lights, and Clearance Lights

a. Taillights.

Note. The key letters shown in parentheses are in figure 67.

- (1) *Removal.* Refer to paragraph 72b.
- (2) *Disassembly.* Unscrew six screws which secure door assembly (E) and remove door assembly and gasket (D). Screws are fitted with retainers and will remain in door. Remove six round-head screws securing socket and wiring assembly (B) in body (A). Remove socket and wiring assembly, with attached parts, from body.
- (3) *Cleaning.* Clean exterior of body and door with mineral spirits paint thinner or dry-cleaning solvent. If necessary to clean interior of body or sockets of socket and wiring assembly, use clean water and soap solution and dry thoroughly.
- (4) *Inspection and repair.* Inspect door assembly (E) for cracks, warpage, cracked or broken lenses, or evidence of leakage around lens gasket.

Note. It is not practical to attempt to replace lenses or lens gaskets in door assembly since these are clinched in place to make a watertight seal.

Inspect body (A) for cracks or evidence of leakage. Replace body if damaged. Check socket and wiring assembly (B) to make sure grommets, sockets, socket plates, cables, spring, connectors, and cable are in good condition and will make good electrical and watertight connections when installed. Pay particular attention to triangular grommet at rear of baffle plate to make sure cables are cemented securely to grommet and grommet will make watertight seal in body when installed. Replace defective parts or assembly.

- (5) *Assembly.* Position socket and wiring assembly (B) in body. Place double socket assembly at top of baffle

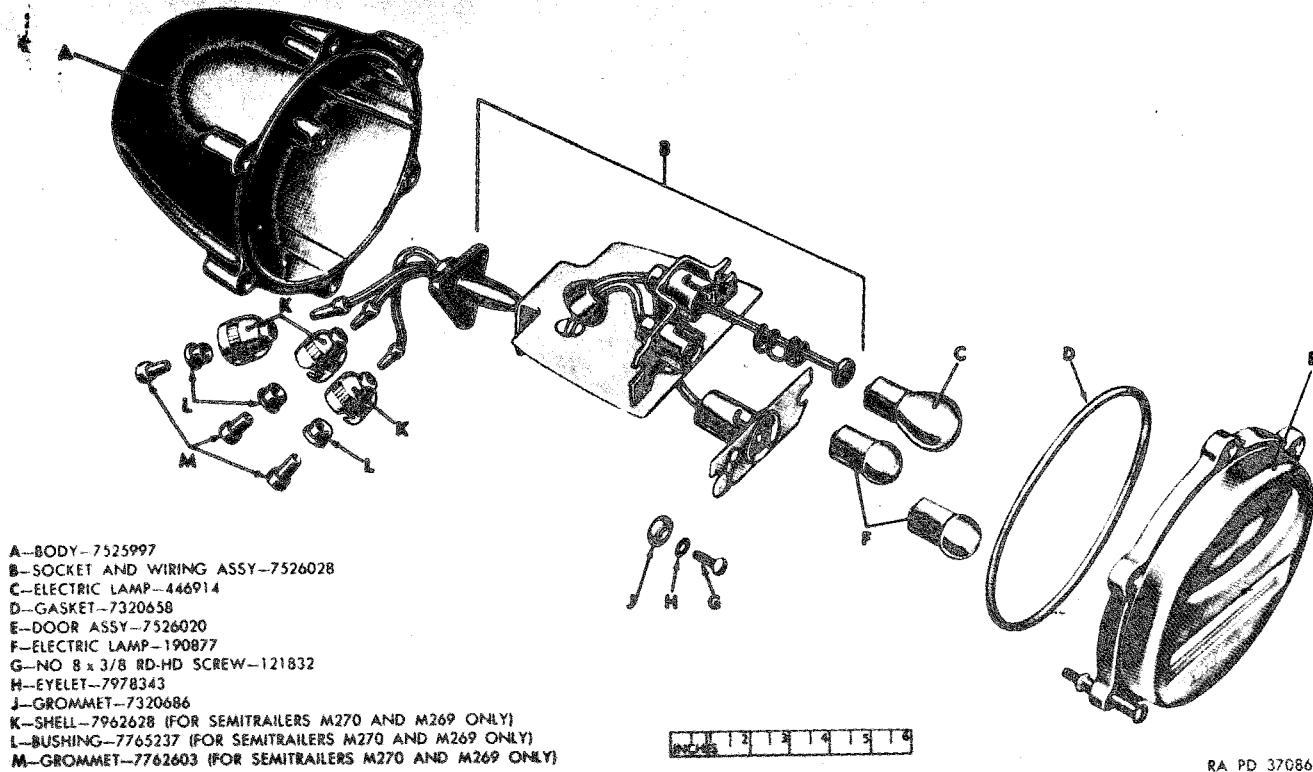

RA PD 370869

Figure 67. Service tail and stop and blackout taillight 7411002—partial exploded view.

plate. Aline holes in socket and wiring assembly and body and install six No. 8 x 3/8 round-head screws. If lamps were removed, press each into socket and turn clockwise to lock in place. Position new gasket in groove in door and install door.

(6) *Installation.* Refer to paragraph 71c.

b. *Blackout Stoplight* (fig. 68).

(1) *Removal.* Refer to paragraph 74b.

(2) *Disassembly.* Remove two oval-head screws securing door assembly to body. Remove door assembly and door gasket from body. Remove door gasket from door. Remove two shouldered screws and plain washers securing socket and wiring assembly to body. Pull socket and wiring assembly from body. Remove two grommets from socket plate.

(3) *Cleaning.* Clean exterior of body and door with mineral spirits paint thinner or dry-cleaning solvent. If necessary to clean interior of body or socket plate with attached parts, use clean water and soap solution. Dry thoroughly.

(4) *Inspection and repair.* Inspect door assembly for cracks, warpage, cracked or broken lens, or evidence of leakage around lens gasket.

Note. It is not practical to attempt replacing lens or lens gasket in door assembly since these parts are clinched in place to make a watertight seal.

Inspect body for cracks or evidence of leakage. Replace body if damaged. Check socket and wiring assembly to make sure grommets, socket, strap, cable, and connector are in good condition and will make good electrical and watertight connections when installed. Pay particular attention to body grommet at rear of socket and wiring assembly to make sure cable is cemented securely to grommet and grommet will make watertight seal in body when installed. Replace defective parts of assembly.

(5) *Assembly.* Install grommet in notches on sides of socket and wiring assembly. Position socket and wiring assembly in body by pressing assembly into body until body grommet at rear of assembly seats tightly in opening at rear of body. Aline holes in grommets installed in socket and wiring assembly with mounting holes in body and secure with two plain washers and shouldered screws. Install a new door gasket in

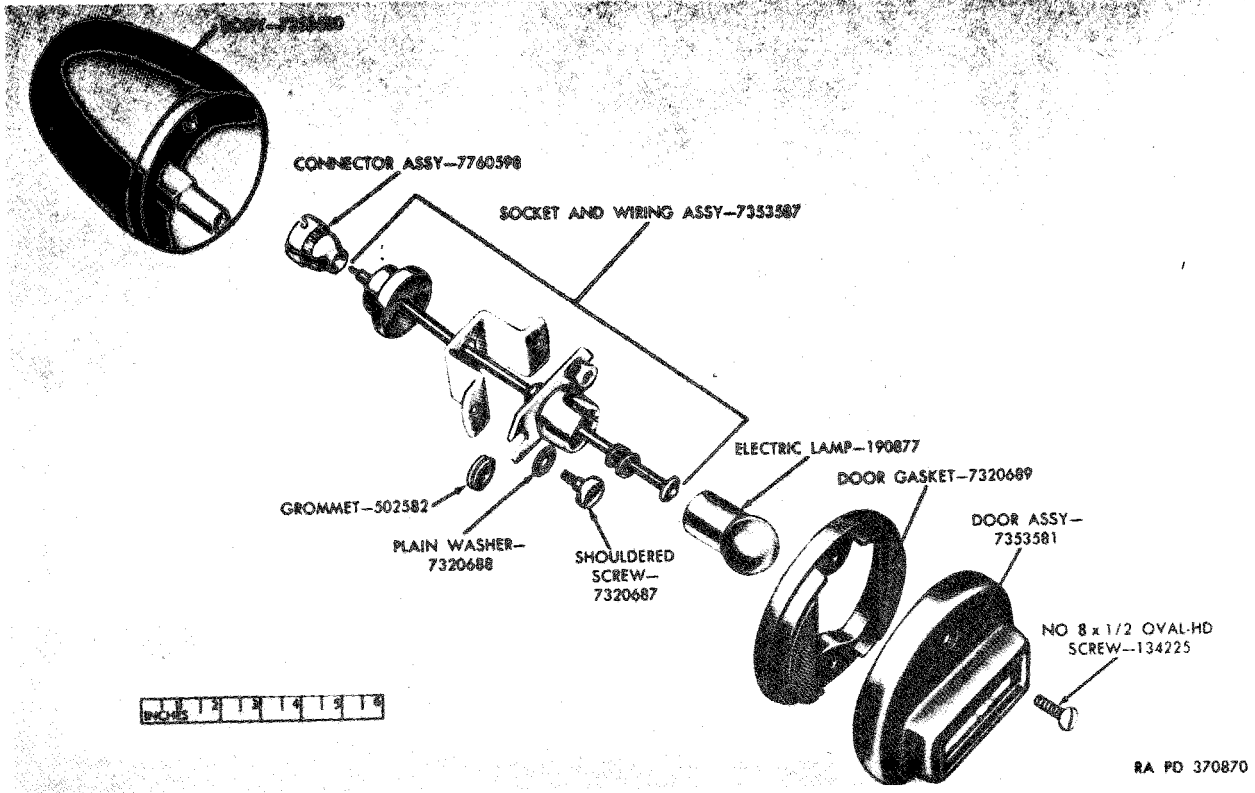

Figure 68. Blackout stoplight assembly 7527682—partial exploded view.

door. Position door assembly on body anti secure with two No. 8 x ½ oval-head screws.

(6) *Installation.* Refer to paragraph 74c.

c. Directional Light (Semitrailers M270 and M269) (fig. 69).

(1) *Removal.* Refer to paragraph 75b.

(2) *Disassembly.* Remove lens retaining wire securing lens in body. Remove lens and lens gasket. Remove hex-nut, internal-teeth lockwasher, and mounting pad from mounting bolt.

(3) *Cleaning.* Clean exterior of body with mineral spirits paint thinner or dry-cleaning solvent. If necessary to clean interior of body or socket use clean water and soap solution and dry thoroughly.

(4) *Inspection and repair.* Inspect body for dents, breaks, or evidence of leakage. Check that socket and cable are in good condition and will make good electrical connection.

Note. It is not practical to attempt replacing socket assembly located in body as these parts are spot welded to body.

If lens is cracked or broken, install new lens. To replace cable, cut terminal from lamp end of cable and withdraw cable through mounting bolt. To in-

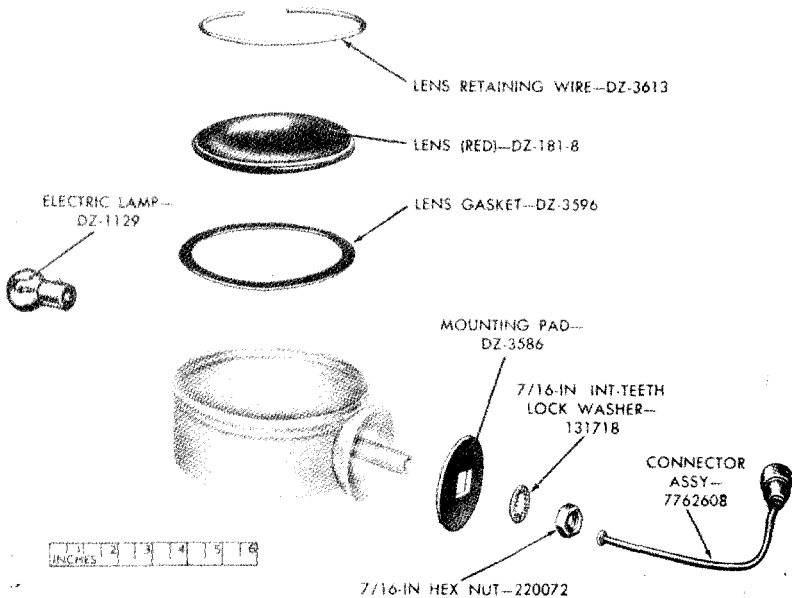

Figure 69. Directional light assembly 8389855—exploded view.

stall cable, insert bare end of cable through mounting bolt and socket and solder terminal to end of cable.

- (5) *Assembly.* Install mounting pad over mounting bolt and against body base. Loosely install 7/16-inch internal-teeth lockwasher and 7/16-inch hex nut on mounting bolt. Position new lens gasket on internal shoulder of body. Place lens on lens gasket and secure with lens retaining wire.

- (6) *Installation.* Refer to paragraph 75c.

d, *Clearance Lights* (fig. 70).

- (1) *Removal.* Refer to paragraph 73b.
- (2) *Disassembly.* Unscrew two screws which secure clearance light door and remove door. Lens is clipped to door by two speed nuts and should not fall out on removal of door. On blackout clearance lights, filter is cemented to lens. To remove lens or filter assembly, pry off two speed nuts. Remove lamp by pressing in, twisting about one-eighth turn counterclockwise and withdrawing. Unscrew round-head machine screw next to socket and remove. Pull rubber grommet and socket assembly out of base. Bend flat surface of grommet back to expose flange on socket and draw socket out of grommet. Remove ground strap from under socket flange. Pull socket contact, spring, and cable out of socket.
- (3) *Cleaning.* Clean exterior of cover with mineral spirits paint thinner or dry-cleaning solvent. If necessary to clean interior of cover, lenses, filters, or socket, use clean water and soap solution and dry thoroughly.
- (4) *Inspection and repair.* Inspect door for cracks, warpage, cracked or broken lenses, filters or shields and attaching screws for serviceability. Check grommet for distortion and pliability. Should it appear that lens does not seat with some pressure on grommet, replace grommet. Check socket assembly to make sure grommet, ground connector strap, socket, cable, and connectors are in good condition and will make good electrical and watertight connections when installed. Make sure grommet is pliable and fits tightly to prevent water from entering unit. Replace defective parts at assembly. Individual parts of socket assembly may be installed without complete disassembly. Moving parts of socket can be installed by pulling cable out through

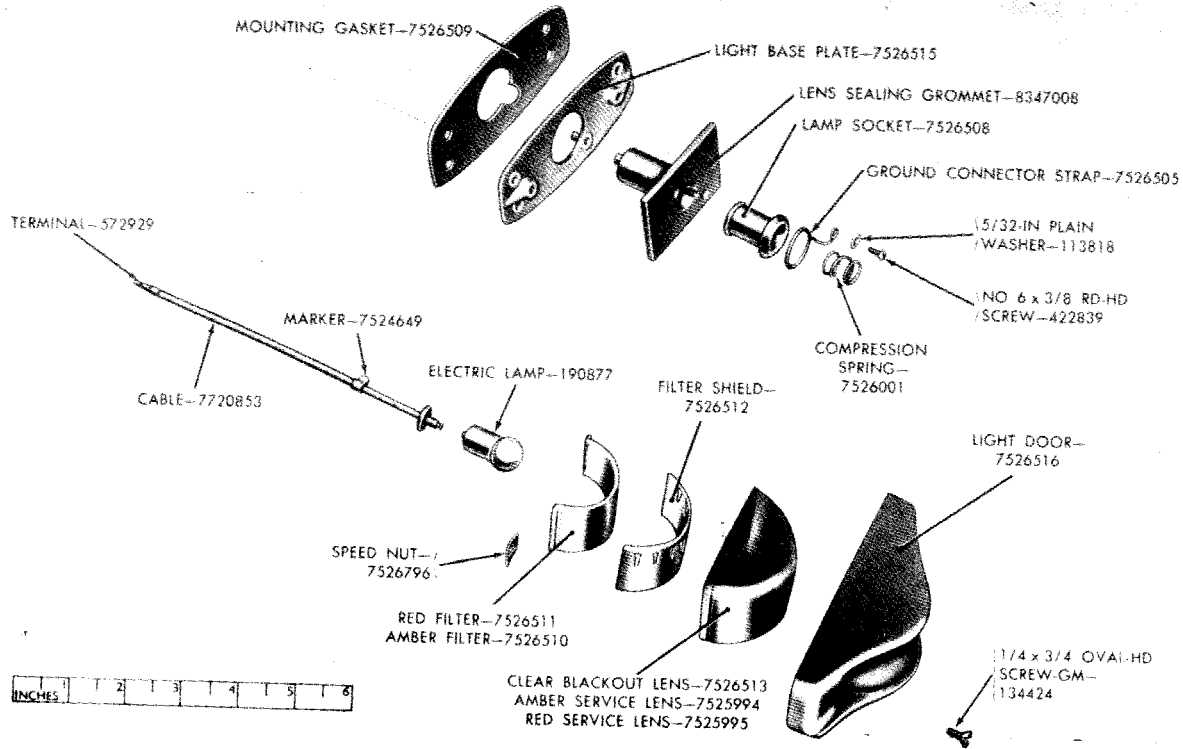

RA PD 370872

Figure 70. Clearance light assembly—exploded view.

socket. To remove cable, take off grommet, bushing and shell at end of cable. Contact in socket is made by coiling strands of cable at socket end, into flat area, larger than hole in washer-type insulator and filling area with solder. Insulator must be installed before contact is constructed. In changing cable, marker must be removed. Be sure to replace with new marker with identical circuit number.

- (5) *Assembly.* Insert socket into grommet. Flange on socket must fit into groove in flat area of grommet. To fit flange into groove, bend flat area back over cylindrical section and force socket into position. If cable has been removed, insert cable end through insulator and spring, through bottom of socket and pull through. Solder on terminal if one is not on cable, and slide bushing, grommet and shell onto cable. Install light, without cover, on vehicle, securing with four screws, lockwashers, and nuts, making certain grommet is well seated in position in base. Position lens and secure to door with two speed nuts. Position cover and secure with two oval-head screws.
- (6) *Installation.* Refer to paragraph 73c.

Section VII. REPAIR AND REBUILD OF FRAME

106. Cleaning and Inspection

a. Cleaning. Use steam or water under pressure and stiff brush to remove heavy accumulations of dirt. Use mineral spirits paint thinner or dry-cleaning solvent to remove grease.

b. Inspection. Inspect rails and cross members for cracks, bends, or damage. Inspect all welded seams and joints. Inspect all riveted and welded brackets, pockets, angles, eyes, and other attached details. Repair or replace damaged parts.

107. Repair

No established rules can be made of the necessity, length, or kind of reinforcements to install on frame members which have been bent, cracked, or broken. A complete part of a welded structure, such as a cross member, should not be removed if damaged. The part should remain in place and a reinforcement welded into place over the damaged area. Reinforcements can be made with channel, angle, or flat stock. Use electric arc welding when replacing damaged members. Do not weld on edges of frame members, as this will weaken them

and encourage development of new cracks. Refer to TM 9-2852 for welding theory and application. Brackets and other parts that are broken or damaged must be repaired or replaced. Cut off or drill and drive out all rivets from part to be replaced. Install new parts, using new rivets.

Section VIII. REPAIR AND REBUILD OF DECK AND STAKES

108. Cleaning and Inspection

a. Cleaning. Use steam or water and stiff brush to remove dirt. Use mineral spirits, paint thinner or dry-cleaning solvent to remove grease.

b. Inspection. Inspect floor for cracked or damaged planks and wear strips for loose fastenings. Inspect stake assemblies for broken or cracked stake, broken or missing chain loops, or damaged stake shoes. Repair or replace damaged parts.

109. Repair

Floor planks may be repaired by cutting out damaged sections and replacing. Ends of planks are cut off square and splices must be made so all ends will rest on cross members. Splices in adjacent planks should not be made on same cross member. Pry stake shoe from base of stake, position new stake shoe and secure with four drive screws. Broken or damaged chain loops can be replaced by removing two square nuts, roundhead screws, and lockwashers and removing chain loop. Position chain loop on opposite sides of stake, align holes and secure with two 1/4 x 5 1/16 roundhead screws, 1/4-inch bolt size lockwashers, and 1/4-inch square nuts.

Section IX. REPAIR AND REBUILD STANDARDS

110. General

The repair and rebuild standards included herein give the minimum, maximum, and key clearances of new or rebuild parts. They also give wear limits which indicate that point to which a part or parts may be worn before replacement, in order to receive maximum service with minimum replacement. Normally, all parts which have not been worn beyond the dimensions shown in the "wear limits" column or damaged from corrosion will be approved for service.

111. Brakes

a. Brake Shoe Bushing (Semitrailers M270 and M269).

<i>Fig. No.</i>	<i>Ref. letter</i>	<i>Point of measurement</i>	<i>Sizes and fits of new parts</i>	<i>Wear limits</i>
71	A	Inside diameter of bushing	1.373 to 1.374	1.406

b. Brake Drum.

71	B	Inside diameter of braking surface	16.495 to 16.05	Refinish surface if scored or if runout exceeds 0.007 inch. Replace if drum diameter is cut to more than 16.730 inches.
----	---	--	-----------------	---

112. Axle

<i>Fig No.</i>	<i>Ref. letter</i>	<i>Point of measurement</i>	<i>Sizes and fits of new parts</i>	<i>Wear limits</i>
71	C	Outside diameter of inner bearing surface	3.4998 to 3.4988	3.464
71	D	Outside diameter of outer bearing surface	3.3748 to 3.3738	3.348

113. Tube, with Brackets, Assembly (Trunnion Cross Tube)

a. Spindle.

<i>Fig. No.</i>	<i>Ref. letter</i>	<i>Point of measurement</i>	<i>Sizes and fits of new parts</i>	<i>Wear limits</i>
71	F	Outside diameter of inner bearing surface	3.4998 to 3.4988	3.464
71	E	Outside diameter of outer bearing surface	3.3748 to 3.3738	3.348

b. Mounting Bracket.

<i>Fig. No.</i>	<i>Ref. letter</i>	<i>Point of measurement</i>	<i>Sizes and fits of new parts</i>	<i>Wear limits</i>
71	G	Inside diameter of holes	1.125 to 1.128	1.160

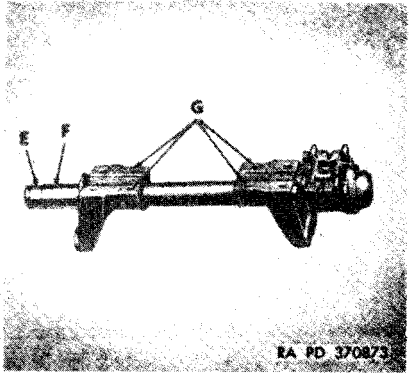
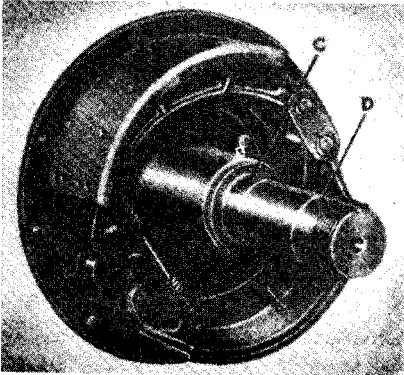
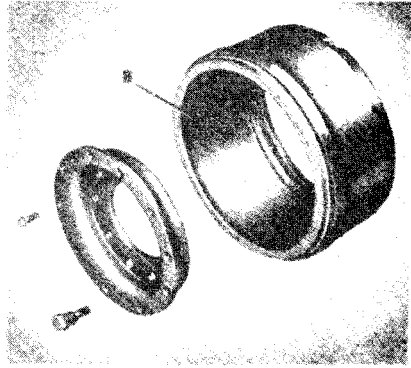
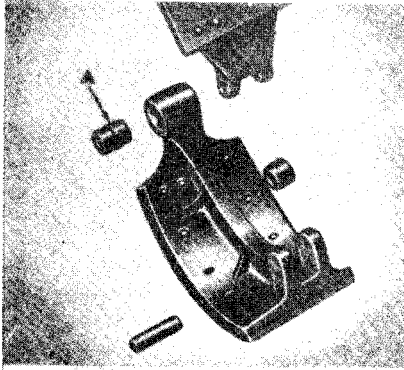

Figure 71. Repair and rebuild standard points of measurement.

CHAPTER 5

SHIPMENT AND STORAGE AND DESTRUCTION OF MATERIEL TO PREVENT ENEMY USE

Section L DOMESTIC SHIPMENT AND LIMITED STORAGE

114. Domestic Shipping Instructions

a. *Preparation For Shipment.* When shipping the 12-ton 4-wheel wrecker low-bed semitrailers M269, M270, and M270A1 by rail, the officer in charge of preparing the shipment will be responsible for furnishing the semitrailers, including on-vehicle materiel (OVM), to the carriers in a serviceable condition, properly cleaned, preserved, painted, and lubricated as prescribed in SB 9-4. For instructions on loading and blocking the semitrailers on flatcars, refer to paragraphs 116 and 117.

b. *Removal Of Preservatives Before Shipment.* The removal of preservatives is the responsibility of organizations receiving shipments. Personnel withdrawing the semitrailers from storage for domestic shipment must not remove preservatives other than to insure that materiel is complete and serviceable. If it has been determined that preservatives have been removed, they must be restored to the prescribed level prior to shipment.

c. *Army Shipping Documents.* Prepare all Army shipping documents accompanying the semitrailers in accordance with TM 38-705.

115. Limited-Storage Instructions

a. *General.*

- (1) Semitrailers received for storage and already processed for domestic shipment must not be reprocessed unless inspection performed on receipt of semitrailers reveals corrosion, deterioration, etc.
- (2) Completely process semitrailers upon receipt directly from manufacturing facilities or if the processing data recorded on the tag indicates that preservatives have been rendered ineffective by operation or freight shipping damage.

- (3) Semitrailers to be prepared for limited storage must be given a limited technical inspection and processed as prescribed on SB 9-4.

b. Receiving Inspections.

- (1) Report of semitrailers received for storage in a damaged condition or improperly prepared for shipment will be made on DD Form 6 (Report of Damaged or Improper Shipment), in accordance with AR 700-58.
- (2) When semitrailers are inactivated, they will be processed in accordance with SB 9-4.
- (3) Immediately upon receipt of semitrailers for storage, they must be inspected and serviced as prescribed in paragraphs 19 through 22. Perform a systematic inspection and replace or repair all missing or broken parts. If repairs are beyond the scope of the unit and the semitrailers will be inactivated for an appreciable length of time, place them in limited storage and attach tags specifying the repairs needed. The reports of these conditions will be submitted by the unit commander for action by any ordnance maintenance unit.

c. Inspection During Storage. Perform a visual inspection periodically to determine general condition. If corrosion is found on any part, remove it and clean and paint or treat with prescribed preservatives.

Note. Touch-up painting will be in accordance with TM 9-2851.

d. Removal From Storage.

- (1) If the semitrailers are not shipped or issued upon expiration of the limited-storage period, proceed as applicable in accordance with SB 9-4.
- (2) If the semitrailers are not shipped or issued upon expiration of the limited-storage period, they need not be reprocessed upon removal from storage unless inspection reveals it to be necessary according to anticipated in-transit weather conditions.
- (3) Deprocess the semitrailers in accordance with SB 9-4 when it has been ascertained that they are to be placed into immediate service. Inspect and service semitrailers as prescribed in paragraphs 19 through 22.
- (4) Repair or replace all items tagged in accordance with b (3) above.

e. Storage Site. Whenever possible, the preferred type of storage is under cover in open sheds or warehouses. When

it is necessary to store the semitrailers outdoors, select the storage site in accordance with AR 700-2300-1 and protect the semitrailers against the elements as prescribed in TB ORD 379.

116. Loading the Semitrailers on Railroad Flatcars

For method of loading and general loading rules pertaining to rail shipment of ordnance vehicles, see TM 9-1005 and TB 9-OSSC-G.

Warning: The height and width of vehicles, when prepared for rail transportation, must not exceed the limitations indicated by the loading table in TB 9-OSSC-G. Whenever possible, local transportation officers will be consulted about the limitations of the particular railroad lines to be used for the movement in order to avoid delays, danger, or damage to equipment.

117. Blocking the Semitrailers on Railroad Flatcars

a. General. All blocking instructions specified are minimum and are in accordance with Pamphlet No. MD-7, "Rules Governing the Loading of Department of Defense Materiel on Open Top Cars" of the Association of American Railroads. Additional blocking may be added as required, at the discretion of the officer in charge. Semitrailers illustrated in figure are double-loaded on one flatcar in order to conserve space. Blocking instructions are the same for one or two trailers, unless indicated otherwise. Separate semitrailers by suitable dunnage (fig. 72),

Note. Any loading instructions, regardless of source, which appear to be in conflict with this publication or existing loading rules of the carriers, must be submitted for approval to the Chief of Ordnance, Headquarters of the Army, Washington 25, D. C.

b. Brake Wheel Clearance A. Load the semitrailers on flatcars, with a minimum clearance of at least 4 inches below and 6 inches above, behind, and to each side of the brake wheel. Brake wheel clearance may be increased provided it does not upset the balanced location of the load.

c. Chock Blocks B (6 x 8 x 24, six required). Position chock blocks B as shown in figure 72. Place blocks against a 3 x 10 support of suitable length and nail together with forty penny nails.

d. Support C (3 x 10, length to suit). Position plank C against trailer-bed and nail checks B to car floor with forty-penny nails. Toenail sides of chock blocks with forty-penny nails.

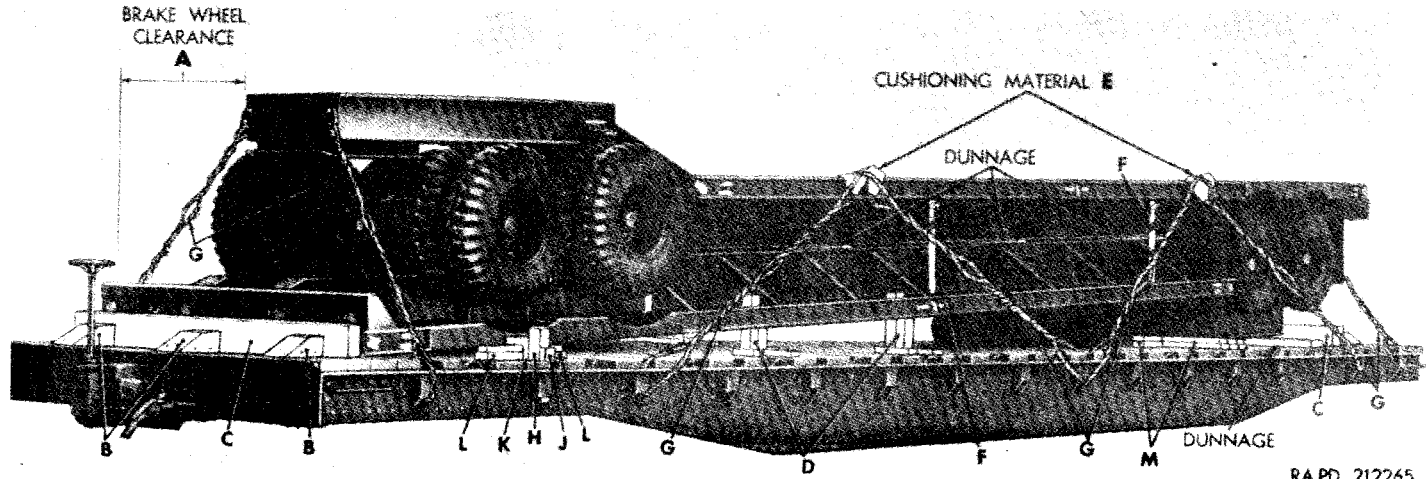

RAPD 212265

Figure 72. Blocking the Semitrailers on Railroad Flatcars

e. *Supports D (4 x 4, length to suit, four required minimum).* Place supports E under trailer-bed frame at suitable points as shown in figure 72. Toenail to car floor with thirtypenny nails. Place 2 x 4 cleats around supports D and nail to car floor.

f. *Cushioning Material E.* Place cushioning material as required at all points of contact with strapping or dunnage.

g. *Straps F (2 x 0.50 high-tension steel straps).* Pass steel straps through shackles and fasten trailers to each other.

h. *Cable or Wire G 5/8-in, 6 x 7 steel cable or three strands No. 8 black annealed wire, lengths to suit).* Pass cable or wire through stake pockets of car and through suitable points of trailers' as illustrated in figure 72. Tighten cable or wire by twisting with steel rod or pipe.

i. *Pocket Stake H (6 x 6 x length to suit).* Place stake H in nearest convenient stake pocket and, lock in place with wedge J (j. below).

j. *Wedge J (fashion to suit).* Proceed as in i (above).

k. *Brace K (6 z 6 x length to suit).* Position brace K from pocket stake H to fit snugly against trailer body.

l. *Cleat L (2 x 4 x random length).* Nail double cleats to car floor in a manner that will prevent brace K from shifting as shown in figure 72.

m. *Cleats M (2 z 4 z random length).* Nail double cleats M to car floor against trailer body to prevent shifting and nail back-up supports to cleats as shown in figure 72.

n. *Dunnage.* Place dunnage at all points of contact where rubbing may occur.

118. Marking

a. Identification marking will be stamped on metal tags, then dipped in ordnance yellow paint. Attach securely with soft wire to the front and rear of each trailer.

b. Further marking and processing information will be as prescribed in TM 9-1005.

Section II. DESTRUCTION OF MATERIEL TO PREVENT ENEMY USE

119. General

a. Destruction of the 12-ton 4-wheel wrecker low-bed semi-trailers M269, M270, and M270A1, when subject to capture or abandonment in the combat zone, will be undertaken by the using arm only when, in the judgment of the unit commander concerned, such action is necessary in accordance with

orders of, or policy established by, the army commander. When in the possession of ordnance maintenance personnel, destruction will be in accordance with FM 9-5 and the information below as applicable.

b. The information which follows is for guidance only. Certain of the procedures outlined require the use of explosives and incendiary grenades which normally may not be authorized items for the vehicle. The issue of these and related materials, and the conditions under which destruction will be effected, are command decisions in each case, according to the tactical situation. Of the several means of destruction, those most generally applicable are-

Mechanical-Requires axe, pick mattock, sledge, crowbar, or similar implement.

Burning -Requires gasoline, oil, incendiary grenades, or other flammables.

Demolition-Requires suitable explosives or ammunition.

Gunfire -Includes artillery, machine guns, rifles using rifle grenades, and launchers using antitank rockets. Under some circumstances hand grenades may be used.

In general, destruction of essential parts, followed by burning, will usually be sufficient to render the materiel useless. However, selection of the particular method of destruction requires imagination and resourcefulness in the utilization of the facilities at hand under the existing conditions. Time is usually critical.

c. If destruction to prevent enemy use is resorted to, the materiel must be so badly damaged that it cannot be restored to a usable condition in the combat zone either by repair or cannibalization. Adequate destruction requires that all parts essential to the operation of the materiel, including essential spare parts, be destroyed or damaged beyond repair. However, when lack of time and personnel prevents destruction of all parts, priority is given to the destruction of those parts most difficult to replace. Equally important, the same essential parts must be destroyed on all like materiel so that the enemy cannot construct one complete unit from several damaged ones.

d. If destruction is directed, due consideration should be given to—

- (1) Selection of a point of destruction that will cause greatest obstruction to enemy movement and also prevent hazard to friendly troops from fragments or

ricocheting projectiles which may occur incidental to the destruction.

- (2) Observance of appropriate safety precautions.

120. Method No. 1 –Destruction by Demolition

a. Planning for simultaneous detonation, prepare five 2-pound charges of EXPLOSIVE, TNT (two 1-pound blocks or equivalent per charge together with the necessary detonating cord to make up each charge). Place the charges as follows:

- (1) Set the *first* charge on the *left front* axle and trunnion assembly.
- (2) Set the *second* charge on the *right front* axle and trunnion assembly.
- (3) Set the *third* charge on the *left rear* axle and trunnion assembly.
- (4) Set the fourth charge on the *right rear* axle and trunnion assembly.
- (5) Set the *fifth* charge on the gooseneck.

b. Connect the five charges for simultaneous detonation with detonating cord.

c. Provide for dual priming to minimize the possibility of a misfire. For priming, either a nonelectric blasting cap crimped to at least 5 feet of safety fuse (safety fuse burns at the rate of 1 foot in approximately 4 seconds; test before using) or an electric blasting cap and firing wire may be used. Safety fuse, which contains black powder, and nonelectric blasting caps must be protected from moisture at all times. The safety fuse may be ignited by a fuse lighter or a match; the electric blasting cap requires a blasting machine or equivalent source of electricity.

Caution: Keep the blasting caps, detonating cord, and safety fuse separated from the charges until required for use.

Note. For the successful execution of methods of destruction involving the use of demolition materials, all personnel concerned will be thoroughly familiar with the pertinent provisions of FM 5-25. Training and careful planning are essential.

d. Destroy the tires by placing an incendiary grenade under each tire. Fire the grenades. The detonation of the explosive charges should be delayed until the incendiary fires are well started. This will prevent the fires from being extinguished by the blast when the charges are detonated.

e. Detonate the charges. If primed with nonelectric blasting cap and safety fuse, ignite and take cover. If primed with electric blasting cap, take cover before firing the charges.

Caution: Cover must be taken without delay since an early explosion of the charges may be caused by the incendiary fires.

The danger zone is approximately 250 yards. Elapsed time: about 5 minutes.

121. Method No. 2—Destruction by Burning

a. Using an axe, pick mattock, sledge, or other heavy implement, smash the lights, electric receptacles and switches, reflectors, couplings, air lines, brake chambers, and king pin..

b. Slash tires. If tires are inflated, exercise care to prevent injury should the tires blow out while being slashed. Whenever practicable, it is usually preferable to deflate tires before slashing.

c. Explosive ammunition, if available nearby, should be removed from packing or other protective material. Place ammunition on and about the semitrailer, so that it will be fully exposed to the fire and in such locations that the greatest damage will result from its detonation. Remove any safety devices from ammunition. Place combustible such as wood, paper, or rags under the semitrailer.

d. Pour gasoline and oil over the combustible and under and over the entire semitrailer. Ignite by means of an incendiary grenade fired from a safe distance, a burst from a flame thrower, a combustible train of suitable length, or other appropriate means. Take cover immediately. A very hot fire is required to render the materiel useless.

Caution: Cover must be taken without delay since an early explosion of the explosive ammunition, if present, may be caused by the fire. Due consideration should be given to the highly flammable nature of gasoline and its vapor. Carelessness in its use may result in painful burns.

If explosive ammunition is present, the danger zone is approximately 500 yards. Elapsed time: about 5 minutes.

122. Method No. 3—Destruction by Gunfire

a. Ordinarily destruction of the tires is effected incidental to and in conjunction with the destruction of the semitrailer by gunfire. However, if such destruction is not practicable, destroy the tires as directed in paragraph 120d or 121b.

b. Destroy the semitrailer by gunfire using artillery, machine guns, rifles using rifle grenades, or launchers using antitank rockets. Fire on the semitrailer aiming at the wheels, axles,

and gooseneck. Although one well-placed direct hit may render the semitrailer temporarily useless, several hits are usually required for complete destruction.

Caution: Firing artillery at ranges of 500 yards or less should be from cover. Firing rifle grenades or antitank rockets should be from cover.

Elapsed time: about 4 minutes.

APPENDIX

REFERENCES

1. Publication Indexes

The following indexes should be consulted frequently for latest changes to or revisions of references given in this appendix and for new publications relating to materiel covered in this manual.

Index of Army Motion Pictures, Film Strips, DA Pam 108-1
Slides, and Phono-Recordings.

Military Publications:

Index of Administrative PublicationsDA Pam 310-1
Index of Blank FormsDA Pam 310-2
Index of Graphic Training Aids and DevicesDA Pam 310-5
Index of Supply Manuals-Ordnance CorpsDA Pam 310-29
Index of Technical Manuals, Technical Regu-DA Pam 310-4
lations, Technical Bulletins, Supply Bulle-
tins, Lubrication Orders, and Modification
Work Orders.
Index of Training PublicationsDA Pam 310-3

2. Supply Manuals

The following manuals of the Department of the Army Supply Manual pertain to this materiel:

a. Destruction to Prevent Enemy Use.

Explosives, Bulk Propellants and Explosive De- SM 9-5-1375
vices.

b. Repair and Rebuild.

Abrasives, Adhesives, Cleaners, Preserva- ORD 3 SNL K-1
tives, Lubricants, Recoil Fluids, Special
Oils, and Related Maintenance Materials.

Antifriction Bearings and Related Items ORD 5 SNL H-12

IntroductionORD 1

Common Hand ToolsORD 3 SNL J-17

Lubricating Fittings, Oil Filters, and Oil ORD 5 SNL H-16
Filter Elements.

Miscellaneous HardwareORD 5 SNL H-2

Motor Vehicles, Trailers, and CyclesSM 9-5-2300

Oil SealsORD 5 SNL H-13
 Pipe and Hose FittingsORD 5 SNL H-6
 Shop Set, Headquarters and Service Company, Depot Maintenance, Automotive or Armament. ORD 6 SNL J-9, Sec. 2
 Shop Set, Maintenance (Field), Automotive. ORD 6 SNL J-8, Sec. 13
 Shop Set, Tire Rebuild Company, Depot Maintenance. ORD 6 SNL J-9, Sec. 10
 Soldering, Metallizing, Brazing, and Welding Materials; Gases and Related Items. ORD 3 SNL K-2
 Standard Electrical ComponentsORD 5 SNL H-4
 Standard HardwareORD 5 SNL H-1
 Tool Set, General Mechanic's (41-T-3534-30) ORD 6 SNL J-10, Sec. 4
 Tool Set, Organizational Maintenance (2d Echelon), No. 1, Common (5180-754-0654) ORD 6-SNL J-7, Sec. 1
 Tool Set, Organizational Maintenance (2d Echelon), No. 2 Common (41-T-3538-855) ORD 6 SNL J-7, Sec. 3
 Tool Set, Organizational Maintenance (2d Echelon), Set No. 1, Supplemental (41-T-3538-865). ORD 6 SNL J-7, Sec. 2
 Tool Sets, Field and Depot Maintenance for: Semitrailer, Low-bed, Wrecker, 12-Ton, 4-Wheel, M269, M270. ORD 6 SNL J-16, Sec. 64
 c. Vehicle.
 Semitrailer, Low Bed: Wrecker, 12-Ton 4-Wheel, M269, M270, and M270A1. ORD (*) SNL G-802

3. Forms

The following forms pertain to this materiel:
 DA Form 9-1, Material Inspection Tag
 DA Form 9-3, Processing Record for Shipment and Storage of Vehicle and Boxed Engines
 DA Form 9-4, Vehicular Storage and Servicing Record
 DA Form 9-68, Spot Check Inspection Report for Wheeled and Half-Track Vehicles
 DA Form 9-71, Locator and Inventory Control Card

(*) DA Pam 310-29 for Index of Supply Manuals-Ordnance Corps for published types of manuals of the Ordnance section of the Department of the Army Supply Manuals.

DA Form 9-75, Daily Dispatching Record of Motor Vehicles
 DA Form 9-77, Job Order Register
 DA Form 9-78, Job Order
 DA Form 9-79, Parts Requisition
 DA Form 9-80, Job Order File
 DA Form 9-81, Exchange Part or Unit Identification Tag
 DA Form 348, Driver Qualification Record
 DA Form 460, Preventive Maintenance Roster
 DA Form 461, Preventive Maintenance Service and Inspection for
 Wheel and Half-Track Vehicles
 DA Form 461-5, Limited Technical Inspection
 DA Form 468, Unsatisfactory Equipment Report
 DA Form 478, Organizational Equipment File
 DA Form 865, Work Order
 DA Form 866, Consolidation of Parts
 DA Form 867, Status of Modification Work Order
 DD Form 6, Report of Damaged or Improper Shipment
 DD Form 110, Vehicle and Equipment Operational Record
 DD Form 313, U.S. Government Operator's Permit
 DD Form 317, Preventive Maintenance Service (Sticker-due
 date next service)
 Standard Form 91, Operator's Report of Motor-Vehicle Accident
 Standard Form 94, Statement of Witness

4. Other Publications

The following explanatory publications contain information pertinent to this material and associated equipment:

a. Ammunition.

Report of Malfunctions and Accidents Involving SR 700-45-6
 Ammunition and Explosives (During Training
 or Combat).

Regulations for Firing Ammunition for Training, AR 385-63
 Target Practice, and Combat.

b. Camouflage.

Camouflage, Basic Principles.....FM 5-20
 Camouflage of Vehicles.....FM 5-20B

c. Decontamination.

DecontaminationTM 3-220
 Defense Against CBR Attack.....FM 2140

d. Destruction to Prevent Enemy Use.

Explosives and Demolitions.....FM 5-25
 Ordnance Service in the Field.....FM 9-5

e. General.

Authorized AbbreviationsAR 320-50
 Basic Arctic Manual.....FM 31-70

Dictionary of United States Army Terms	SR 320-51
Driver Selection and Training	TM 21-300
Manual for the Wheeled Vehicle Driver	TM 21-305
Inspection of Ordnance Materiel in Hands of Troops	TM 9-1100
Unsatisfactory Equipment Report	AR 700-38
Semitrailer Wrecker, Low Bed, 12 Ton, 4 Wheel, LO M269, M270, M270A1.	9-8240
Military Symbols	FM 21-30
Military Training	FM 21-5
Military Vehicles	TM 9-2800
Motor Transportation, Operations	FM 25-10
Operations in the Arctic	FM 31-71
Ordnance Maintenance and General Supply in the Field	FM 9-10
Precautions in Handling Gasoline	AR 850-20
Preparation of Ordnance Materiel for Deep-Water Fording.	TM 9-2853
Principles of Automotive Vehicles	TM 9-8000
Accident Reporting	SR 385-10-40
Prevention of Motor Vehicle Accidents	AR 385-55
Techniques of Military Instruction	FM 21-6
<i>f. Operation.</i>	
Operation and Organizational Maintenance: 5-Ton, 6 x 6 Cargo Truck M41, M54; Chassis Truck M40, M61, M139, and M139C; Dump Truck M51; Truck Tractor M52; Medium Wrecker Truck M62; and Tractor Wrecker Truck M246.	TM 9-8028
<i>g. Repair and Rebuild.</i>	
Abrasive, Cleaning, Preserving, Sealing, Adhesive, and Related Materials Issued for Ordnance Materiel.	TM 9-850
Brake and Miscellaneous Equipment (Wagner- Lockheed).	TM 9-1827C
Care and Maintenance of Pneumatic Tires.	TM 9-1870-1
Instruction Guide: Care and Maintenance of Ball and Roller Bearings.	TM 37-265
Instruction Guide: Operation and Maintenance of Ordnance Materiel in Extreme Cold (0° to-65° F.)	TM 9-2855
Instruction Guide: Welding Theory and Application	TM 9-2852
Lubrication	TM 9-2835
Maintenance and Care of Hand Tools	TM 9-867
Maintenance of Supplies and Equipment: Mainte- nance Responsibilities and Shop Operations.	AR 750-5

Ordnance Maintenance: Power Brake Equipment TM 9-8601
 (Midland Steel Products).

Painting Instructions for Field UseTM 9-2851

Power Brake System (Bendix-Westinghouse)TM 9-1827A

Preparation of Ordnance Materiel for Deep-Water TM 9-2853
 Fording.

Tactical Motor Vehicle Inspections and Preventive TM 9-2810
 Maintenance Services.

Uneconomically Repairable Ordnance VehiclesAR 755-2300-2
h. Shipment and Standby or Long-Term Storage.

Army Shipping DocumentTM 38-705

Catalog of Approved Packaging Instructions for Major PS 1000'
 Items and Spare Parts for Ordnance General Supplies.

Instruction Guide: Ordnance Preservation, Packag- TM 9-1.005
 ing, Packing, Storage, and Shipping.

Report of Damaged or Improper ShipmentAR 700-58

Marking of Arctic-Lubricated Materiel and SR 746-30-10
 Equipment.

Marking of Oversea SupplySR 746-30-5

Shipment Digit MarkingSR 746-30-6

Military Standard—Marking or Shipment and MIL STD 129A²
 Storage.

Ordnance Storage and Shipment Chart Group G: TB 9-OSSC-G
 Major Items and Major Combinations of
 Group G.

Packaging of Small Arms Materiel With Volatile TB ORD 623
 Corrosion Inhibitor (VCI).

Processing of Unboxed and Uncrated Equipment for AR 747-30
 Oversea Shipment.

Preservation, Packaging, and Packing of Military TM 38-230
 Supplies and Equipment.

Processing of Unboxed Self-Propelled and Towed Class SB 9-4
 II Ordnance General Supplies and Related Materiel
 for Shipment and Storage.

Protection of Ordnance General Supplies in Open TB ORD 379
 Storage.

Standards for Oversea Shipment and Domestic TB ORD 385
 Issue of Ordnance Materiel Other than Ammu-
 nition and Army Aircraft.

¹Copies may be obtained from National Maintenance Publications Center,
 Raritan Arsenal, Metuchen, New Jersey.

²Copies may be obtained from Aberdeen Proving Ground, Aberdeen,
 Maryland.

I N D E X

	<i>Paragraphs</i>	<i>Page</i>
Air chamber. (See Brake air chambers.)		
Air hose	65	102
Air hose coupling	25,67	45, 104
Air filters:		
Description	10e	23
Operation	59	95
Repair and rebuild	95	138
Air lines:		
Description	10d, e	23
Maintenance	97	138
Air-over-hydraulic brake system (semitrailer M270A1).	4b, 66	13, 102
Air reservoirs:		
Description	10g	24
Drain cock	30	48
Operation	61	98
Repair and rebuild	92	137
Axle:		
Description	9b	18
Rebuild	85	119
Repair and rebuild standards	112	163
Blackout stoplight:		
Differences among models	5e	15
Operation	74	111
Rebuild	105	154
Body and equipment:		
Description	76	113
Removal and installation	77	113
Troubleshooting	50	79
Body frame. (See Frames.)		
Boxes. (See Stowage box and Tool boxes.)		
Brake air chambers:		
Description	10l, m	29,30
Repair and rebuild	93	137
Tests, removal, and installation:		
Semitrailer M270A1	62	99
Semitrailer M270 and M269	63	101
Brake air hose couplings	25	45
Brake drums. (See also Internal brake mechanisms.)		
Description	11	30
Removal and installation	53	82
Repair and rebuild	83	117
Brakes:		
Adjustments	56	90

	Paragraphs	Page
BRAKES-Continued		
Air-over-hydraulic brake system	10i, 66	25, 102
Description and operation	10	18
Difference among models	5d	14
Repair and rebuild	111	162
Troubleshooting	46	74
Break-in	21	44
Chassis frame. (See Frames.)		
Check valve	96	138
Chock block	10h, 103	25, 153
Circuits, light	16c	36
Cleaning:	108	162
Deck		
Frame (body and chassis)	106	161
General	42	65
Spring seat and bearings	55C	88
Clearance lights:	5g	15
Differences among models		
Operation	73	111
Rebuild	105	154
Common tools and equipment	36,80	56,115
Connectors	23-30	44-48
Contols	104	154
Couplings (air hose)	25, 67	45, 104
Couplings (dummy)	26	45
Cylinder. (See Hydraulic master cylinder.)		
Data, tabulated	18	40
Data plates	17	39
Deck:		
Cleaning	108	162
Description	7	17
Inspection	108	162
Repair	109	162
Deficiencies, correction	22	44
Description of semitrailers	4	13
Destruction of materiel to prevent enemy use	119	169
Differences among models	5	14
Directional lights (semitrailers M270and M269):		
Operation	75	112
Repair and rebuild	105	154
Electrical sockets	71	108
Electrical system	71-75	108-112
Emergency airline. (See Airlines.)		
Emergency relay valve:		
Description	10c	23
Differences among models	5c	14
Operation	60	96
Repair and rebuild	91	137
Filter. (See Air filters.)		
Fittings	65	102

	Paragraphs	Page
Fording	33	54
Forms, records, and reports	3	12
Frames (chassis and body):		
Cleaning	106	161
Description	6	16
Differences among models	5	14
Inspection	106	161
Removal and installation	77	113
Repair	107	161
General lubrication instructions	39	57
Handcrank assembly	100	149
Hose. (See Air hose and Hydraulic hose.)		
Hubs :		
Description	11	30
Removal and installation	53	82
Repair and rebuild	83	117
Hydraulic brake system. (See Air-over-hydraulic brake system.)		
Hydraulic hose	65	102
Hydraulic master cylinder (semitrailer M270A1):		
Description	101	29
Removal and installation	62	99
Repair and rebuild	94	137
Inspections in storage	115b, C	166
Internal brake mechanisms:		
Removal and installation:		
Semitrailer M270A1	58	95
Semitrailers M270 and M269	57	94
Repair and rebuild	90	133
Intervehicular cable receptacle and sockets. (See Receptacles and sockets.)		
Kingpin	24	45
Landing gear:		
Description	14	33
Installation	69	106
Rebuild	99	138
Removal	68	104
Troubleshooting	48	77
Landing gear operating handcrank	28	47
Leakage tests:		
Brake air chamber and hydraulic master cylinder	62a	99
Emergency relay valve	60c	97
Lights. (See also Clearance lights, Directional lights, Stoplights, and Taillights.)		
Circuits	16c	36
Description	16	36
Troubleshooting	49	78
Lubrication instructions, general	39	57
Lubrication order	38	57

	Paragraphs	page
Maintenance:		
Allocation	2	3
Field and depot instructions	78-113	115-163
Organizational instructions	39-77	57-113
Preventive service	41-44	64-69
Marking	118	169
Operating instructions	19-33	43-54
Operation:		
On unusual terrain	33	54
Under unusual conditions	32	51
Under usual conditions	31	48
Painting	40	64
Parts:		
Field and depot maintenance	79	115
Organizational maintenance	35	56
Plates, data and service	17	39
Preliminary services	20	43
Preventive maintenance:		
By driver or operator	43	66
By organizational maintenance mechanic	44	69
Services (tables II and III)	41-44	64-69
Purpose	19	43
Receptacles and sockets:		
Descriptions	27	46
Differences among models	5h	16
Rebuild	104	154
Removal and installation	71	108
Records and reports	3	12
Reflectors	5f	15
Reservoir. (See Air reservoir.)		
Scope of manual	1	3
Service air line. (See Air lines.)		
Service plates	17	39
Service upon receipt of materiel	19-22	43, 44
Shipment and storage:		
Blocking semitrailers on flatcars	117	167
Domestic shipping instructions	114	165
Limitex-storage instructions	115	16.5
Loading semitrailers on flatcars	116	167
Marking	118	169
Slack adjusters (semitrailers M270 and M269):		
Description	10m	30
Removal and installation	64	101
Repair and rebuild	98	138
Sockets. (See Receptacles and stockets.)		
Spare wheel:		
Description	13	32
Removal and installation	70	107
Repair and rebuild	102	151

	Paragraphs	Page
Spare wheel and tire carrier operating shaft	29	48
Special tools and equipment	37,81	56,115
Spring bearing plates	87	128
Spring guide bracket side plates	87	128
Spring seat:		
Cleaning	55C	88
Description	9d	18
Removal and instillation	55a, e	87,89
Spring seat bearings	55c, 84	88,119
Springs:		
Description	9a	18
Removal and installation	86	125
Stakes	8	17
Stoplights. (See Blackout stoplights.)		
Storage. (See Shipment and storage.)		
Stowage box:		
Description of box and compartment	15	34
Repair and rebuild	101	150
Suspension:		
Coordination with ordnance maintenance unit	54	86
Description	9	18
Installation	55	87
Removal	54	86
Troubleshooting	47	76
Tabulated data	18	40
Tables :		
Driver's or operator's preventive-maintenance serv- ices (table 119).	43	66
Organizational mechanics or maintenance crews C and D preventive-maintenance services (table III).	44	69
Special tools and equipment for field and depot main- tenance (table IV).	81	115
Special tools and equipment for organizational mainte- nance (table I).	37	56
Taillights:		
Installation	105	154
Rebuild	72	109
Removal	72	109
Terminals, rebuild	104	154
Tire carrier:		
Description	13	32
Removal and installation	70	107
Repair and rebuild	102	151
Tires:		
Description	12	32
Inflation pressure	52a	79
Removal and installation	52c, d	80,81
Tool boxes:		
Description	15	34
Repair and rebuild	101	150

	Paragraphs	Page
Tools and equipment:		
Common:		
Field and depot maintenance	80	115
Organizational maintenance	36	56
Special:		
Field and depot maintenance	81	115
Organizational maintenance	37	56
Torque rods	9,88	18, 130
Troubleshooting	22.45-50	44,73-79
Tube, with brackets, assembly (trunnion cross tube):		
Description	9d	18
Removal and installation	89	132
Repair and rebuild	89	132
Rp-air and rebuild standards	113	163
Tubing	65	102
Valve, emergency relay. (See Emergency relay valve.)		
Wheel brakes	5d, 10	14, 18
Wheels:		
Adjustment of bearings	53C	83
Description	12	32
Removal and installation	52	79
Repair and rebuild	82	115
Wiring:		
Cable, rebuild	104	154
Description	16	36
Removal and installation	71	108

[AG 451.3 (18 Jul 57)]

BY ORDER OF THE SECRETARIES OF THE ARMY AND THE
AIR FORCE:

MAXWELL D. TAYLOR,
General, United States Army,
Chief of Staff.

Official:

HERBERT M. JONES,
Major General, United States Army,
The Adjutant General.

Official:

THOMAS D. WHITE,
Chief of Staff, United States Air Force.

J. L. TARR,

Colonel, *United States Air Force,*
Air Adjutant General.

Distribution:

Active Army:

CNGB

ASA

Technical Stf, DA

Ord Bd

USCONARC

USARADACOM

OS-Maj Cored

MDW

Armies

Corps

Div

Ord Gp

Ord Bn

Ord Co

Ft & Cp

Gen & Br Svc Sch

PMST Sr Div Ord Units

Ord Ammo Cored

Ord Tk Autmv Comd

Gen Depots

Ord See, Gen Depots

Ord Depots

Ports of Emb (OS

Trans Terminal Comd

Army Terminals

OS Sup Agencies

Ord PG

Ord Arsenal

Mil Dist

Ord Proc Dist

MAAG

Mil Msn

JBUSMC

JUSMAG (Greece)

Fld Cornd, AFSWP

NG: State AG; units-same as Active Army.

USAR: None.

For explanation of abbreviations used, see AR 320-50.

